

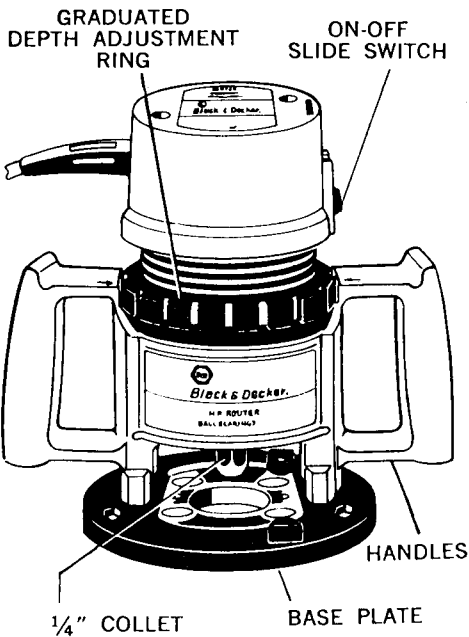

# Black & Decker\*

## OWNER'S MANUAL



**NO. 7600-04  
ROUTER**

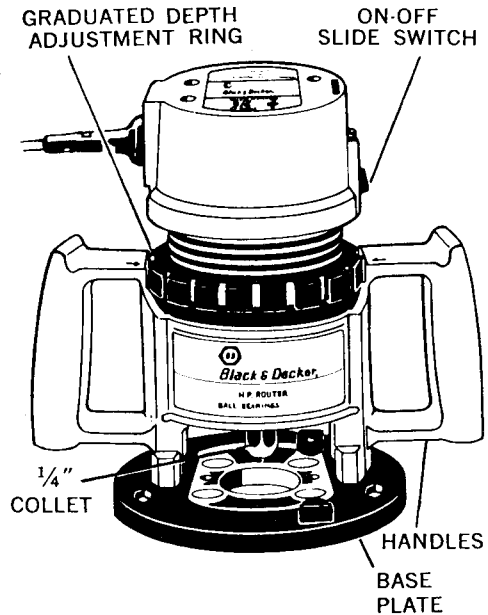

**NO. 7604-04  
ROUTER**

### \*Double Insulated\*

Your Router is DOUBLE-INSULATED for added protection against electric shock. This also eliminates the need for a 3-prong grounding plug.

For personal safety and proper operation of the Router please read all safety rules and instructions in this manual. Don't forget to send in the owner registration card.

THANK YOU for buying BLACK & DECKER!

\* Trademark of The Black And Decker Manufacturing Company. Registered user, Black & Decker Canada Inc., Brockville, Ontario. Product made in U.S.A.

## SAFETY RULES FOR POWER TOOLS

---

1. **Keep Work Area Clean.** Cluttered areas and benches invite accidents.
2. **Avoid Dangerous Environment.** Don't expose power tools to rain. Don't use power tool in damp or wet locations. And keep work area well lit.
3. **Keep Children Away.** All visitors should be kept safe distance from work area.
4. **Store Idle Tools.** When not in use, tools should be stored in dry, high or locked-up place — out of reach of children.
5. **Don't Force Tool.** It will do the job better and safer at the rate for which it was designed.
6. **Use Right Tool.** Don't force small tool or attachment to do the job of a heavy duty tool.
7. **Wear Proper Apparel.** No loose clothing or jewelry to get caught in moving parts. Rubber gloves and footwear are recommended when working outdoors.
8. **Use Safety Glasses** with most tools. Also face or dust mask if cutting operation is dusty.
9. **Don't Abuse Cord.** Never carry tool by cord or yank it to disconnect from receptacle. Keep cord from heat, oil and sharp edges.
10. **Secure Work.** Use clamps or a vise to hold work. It's safer than using your hand and it frees both hands to operate tool.
11. **Don't Overreach.** Keep proper footing and balance at all times.
12. **Maintain Tools With Care.** Keep tools sharp, at all times, and clean for best and safest performance. Follow instructions for lubricating and changing accessories.
13. **Disconnect Tools.** When not in use, before servicing; when changing accessories such as blades, bits, cutters, etc.
14. **Remove Adjusting Keys and Wrenches.** Form habit of checking to see that keys and adjusting wrenches are removed from tool before turning it on.
15. **Avoid Accidental Starting.** Don't carry plugged-in tool with finger on switch. Be sure switch is off when plugging in.
16. **Outdoor Use Extension Cords.** When tool is used outdoors, use only extension cords suitable for use outdoors and so marked.
17. **Do Not Operate** portable electric tools in gaseous or explosive atmospheres. Motors in these tools normally spark, and the sparks might ignite fumes.

## ADDITIONAL SAFETY RULES FOR ROUTERS

---

1. Disconnect plug from power supply before changing bits or making adjustments.
2. Make sure collet nut is securely tightened to prevent router bit from slipping during use.
3. Make sure switch is in the OFF position before plugging into power supply.
4. Use both hands to hold Router against the work.
5. Make sure wing nut adjustment lock is securely tightened before turning tool ON.
6. Wear safety glasses or eye shields when using the Router



No. U2106 EYE SHIELDS . . . Light-weight, one-piece, impact resistant, clear plastic with side shields. Can be worn directly over eyes or over prescription glasses. Comfortable.

CAUTION: Use only accessories recommended by Black & Decker. The use of any other attachment or accessory might be hazardous.

IMPORTANT: Your Router has been designed and built to give many years of trouble-free service on home woodworking projects. **The cutting of metals is not recommended and should be avoided.**

## DOUBLE-INSULATION

---

Your tool is DOUBLE-INSULATED to give you added safety. This means that it is constructed throughout with TWO separate "layers" of electrical insulation or one DOUBLE thickness of insulation between you and the tool's electrical system.

Tools built with this improved insulation system are not intended to be grounded. As a result, your tool is equipped with a two-prong plug which permits you to use any conventional 120 volt electrical outlet without concern for maintaining a ground connection.

NOTE: DOUBLE-INSULATION does not take the place of normal safety precautions when operating this tool. The improved insulation system is for added protection against injury resulting from a possible electrical insulation failure within the tool.

CAUTION: When servicing Double Insulated Tools. USE ONLY IDENTICAL REPLACEMENT PARTS. Replace or repair damaged cords.

## MOTOR

---

Your Black & Decker tool is powered by a B&D-built motor. Be sure your power supply agrees with the nameplate marking.

Volts 50/60 Hz or "AC only" means your tool must be operated only with alternating current and **never** with direct current. Volts DC-60Hz or AC/DC means your tool may be operated with either alternating or direct current.

Voltage decrease of more than 10% will cause loss of power and overheating. All B&D tools are factory tested; if this tool does not operate, check the power supply.

## LUBRICATION & MAINTENANCE

---

The ball bearings used in this tool were lubricated at time of manufacture and periodic relubrication is not required. However it is recommended that, once a year, you take or send the tool to a B&D Service Centre for a thorough cleaning and inspection. Service Centre addresses are shown on the owner registration card packed with your tool.

## 7605-04 ROUTER KIT

### CONTENTS

	Qty.
7605-04 Router	1
740005-02 Owner's Manual	1
133529 Router Kit Box	1
135702-01 Wrench	2
U-59009 1/8" Straight Bit	1
U-58987 1/4" Straight Bit	1
U-59043 1/4" Rounding Over Bit	1
132945 Guide	1
90960-02 Guide Rod	2
(1) Poly Bag Containing:	
406 Hex Nut	4
36382 Wing Screw	4
133521 Clamp	2

### EXTENSION CORD

Before using cord, inspect for loose or exposed wires and damaged insulation. Make any needed repairs or replacement before using your power tool.

To prevent loss of power and overheating, the size of the wires in an extension cord must be of adequate size. To determine the minimum size wire required, see the table below:

Extension Cord Length in Feet	25	50	75	100
Minimum Wire Size (American Wire Gauge):				
120 Volt Tools	18	18	18	16
220 Volt Tools	18	18	18	18

Note: The lower the wire size number, the heavier the wire, and the farther it will carry current without a significant voltage drop.

To prevent disconnection of tool cord from extension cord, make a knot as shown at right.

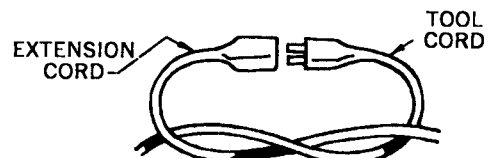

### GENERAL OPERATING INSTRUCTIONS

#### ASSEMBLY

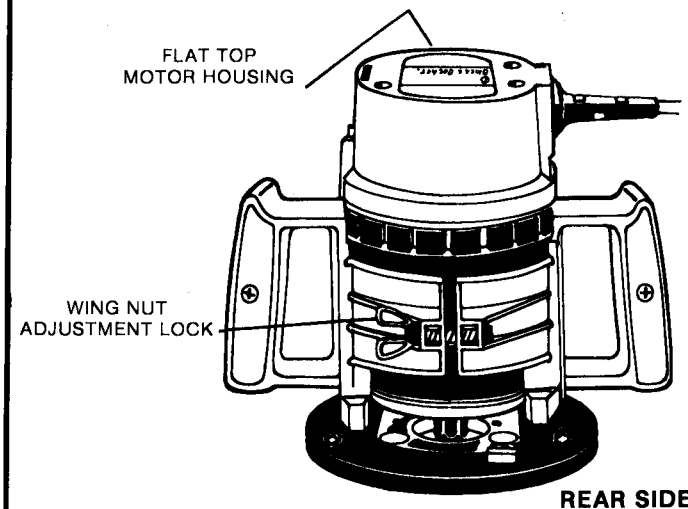
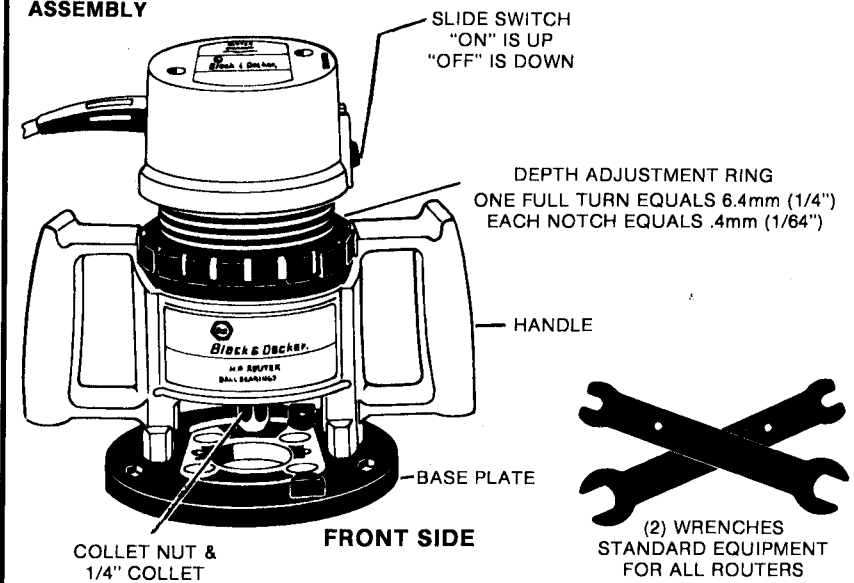

Router is shown assembled for "Right Handed" operation. If "Left Handed" operation is desired loosen wing nut, lift motor housing out of handle frame. Turn 180° and lower motor back into handle frame. Wing nut & screw may also be turned 180° if desired. Retighten wing nut before use.

## ATTACHING BITS AND CUTTERS

**IMPORTANT:** ALWAYS DISCONNECT POWER CORD FROM ELECTRICAL SOURCE BEFORE CHANGING BITS OR CUTTERS.

Your router consists of two major parts: the motor and the base. The motor housing is specially designed with a flat top that forms a firm support when router is in an inverted position for the purpose of attaching bits or cutters. This extra convenience feature leaves both of the operator's hands free to use the necessary wrenches. **Note:** Some may prefer to lay the router over on its side during bit changing.

The shank of the bit or cutter should be inserted as far as possible, then pull bit out 1/16". Use the two open-end wrenches provided to install and remove bits. One wrench is fitted to the flats on the shaft adjacent to the motor housing, the other is used to turn the collet nut. See Figure 3. Tighten collet nut firmly before use.

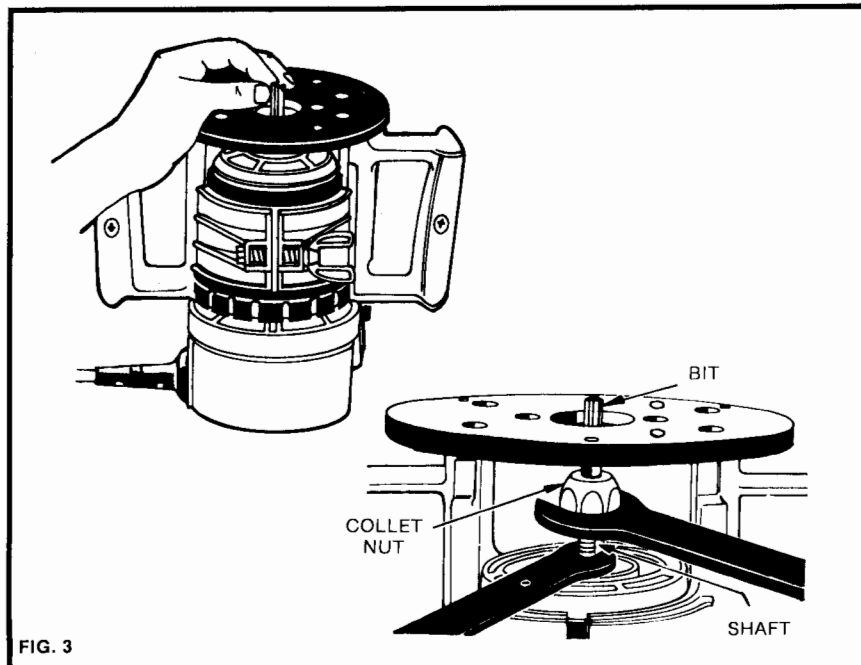

FIG. 3

**CAUTION:** Never tighten collet nut without a 1/4" (.250") size bit inserted into collet. To do so may break or damage collet.

## STARTING & STOPPING THE ROUTER MOTOR

1. Always make sure the switch is OFF before plugging the cord into the power supply.
2. Grasp the Router with both hands on the handles.
3. Extend thumb over to the slide switch. Pushing slide UP turns motor ON. Pushing slide DOWN turns motor OFF (Figure 4).
4. Practise operating the switch a few times without the cord connected to the power supply. This will allow you to get the feel of the switch action.

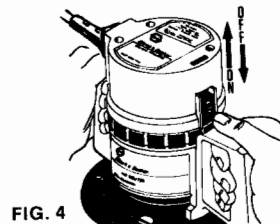
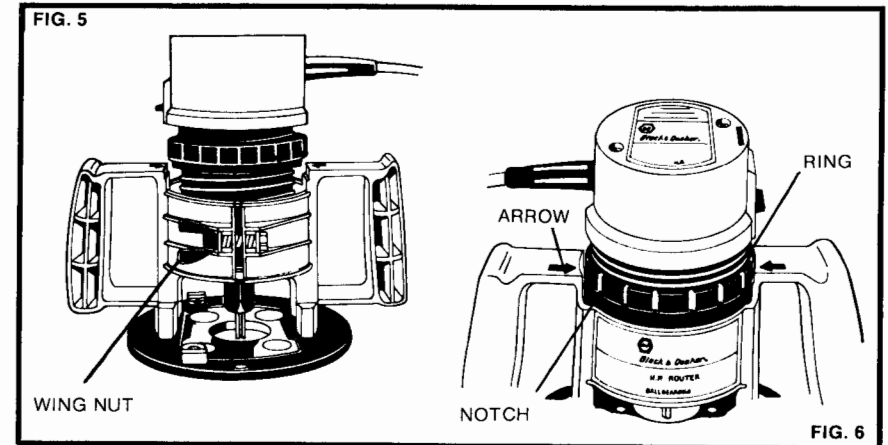

FIG. 4

## DEPTH OF CUT ADJUSTMENTS

1. Never make adjustments when the motor is running.
2. Place Router on a flat surface and loosen large wing nut.
3. Push motor housing down until tip of bit touches the flat surface (Figure 5). It may be necessary to rotate adjustment ring counter-clockwise to permit this.
4. Tighten wing nut to clamp motor housing.
5. Rotate adjustment ring clockwise (downward) until it stops. The bit is now set for a zero cutting depth.
6. Note the location of the adjustment ring relative to the pointer arrows on the tops of the handles (Figure 6). For each full turn of the ring counter-clockwise the bit is lowered 6.4mm (1/4"). Each notch equals .4mm (1/64").
7. Loosen wing nut and push motor housing down until it stops. Retighten wing nut.
8. It is recommended that you make some sample cuts on scrap lumber to check cutting depth and make sure cut looks good.



## USING THE ROUTER

1. Make sure that the material to be cut is clamped down and is stable enough to support the Router during operation.
2. Use both hands on the handles to control the Router.
3. Since the bit rotates clockwise, more efficient cutting will result if you move the Router from left to right as you stand facing the work (Figure 7).
4. Move the Router counter-clockwise when cutting outside edges. Move clockwise when cutting inside edges. See Figure 7.

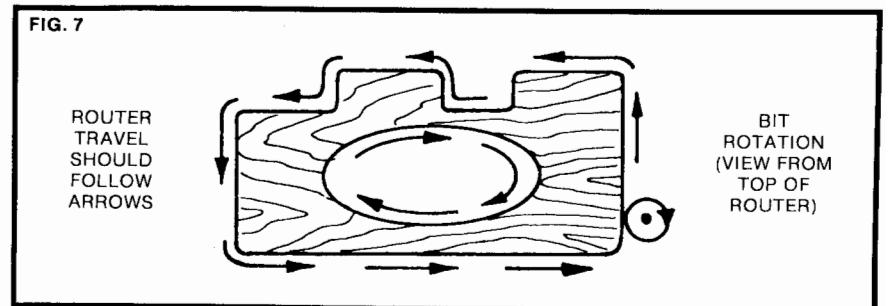

## FEEDING SPEED AND RATE OF CUT

The Router Bit rotates at very high speed and may heat up if the Router is moved too slowly through the wood. Also the wood will show burn marks.

Feeding the Router too fast or with too much cutting depth with large bits or decorating bits, will overload the motor. Use two or more passes for extra-large cuts (over 6.4mm (1/4" deep) especially in hard woods.

Become familiar with the sound and feel of your new Router by making practice cuts in scrap lumber.

## HELPFUL HINTS & RECOMMENDATIONS MAKING YOUR OWN MOULDING

Many types of novel and decorative wood moulding can be easily accomplished with the B & D Router, using either bits or cutters. Such moulding cuts can be made directly along the edge of the work, such as table and desk tops, bookcase shelves, etc.; or they can be made separately and fastened wherever desired.

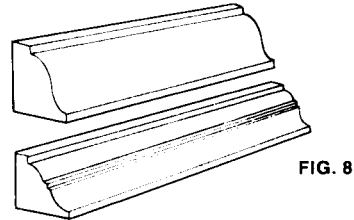

FIG. 8

**Fig. 8** illustrates two types of moulding made with the Router, using the pilot part of the bit to guide tool along the edge of the work. After the moulding is shaped with the Router, a saw is used to cut the moulding from the lumber.

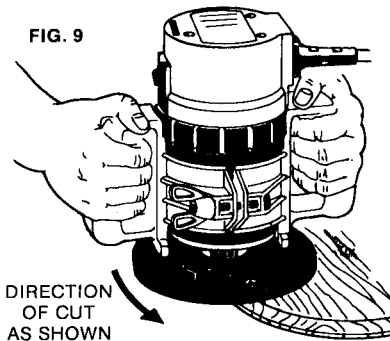

FIG. 9

Mouldings of this type are extremely useful in baseboard work, picture-framing, panelling, etc. By using various combinations of Bits and Cutters, the unique designs possible are limitless.

**Fig. 9** shows a moulded edge being applied to the edge of a table top, using a bit with a pilot end to guide the tool. Use two or more passes to produce deep cuts.

DIRECTION OF CUT AS SHOWN

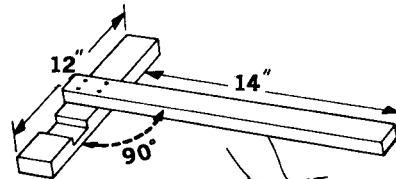

FIG. 10

## T-SQUARE GUIDE

A simple device for guiding the Router when making straight cuts on flat surfaces is the home-made T-Square **Fig. 10**. This T-Square can be easily made out of scrap lumber, but make sure its edges are perfectly smooth and straight. It is placed on the surface being routed and held in position by means of a clamp, as in **Fig. 11**. The Base of the Router is guided firmly along the edge of the T-Square to make a straight cut. Measurements shown in illustration are ideal for most applications with the B & D Router. They may, however, be altered to suit your specific needs.

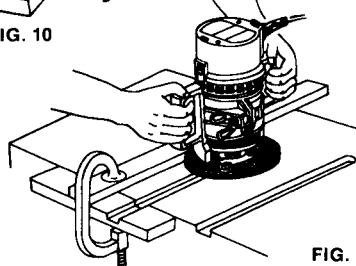

FIG. 11

## MAKING GROOVES OR DADO CUTS

Grooves or dados, frequently used in making shelving or furniture, can be easily and neatly cut with your Router. Two important points to remember are:

1. Do not allow the Router to drift away from its guide.
2. The Router base plate must always have a solid, level surface to ride on so that it won't rock on the workpiece. See Figures 12, 13 and 14 for examples of how to cut grooves.

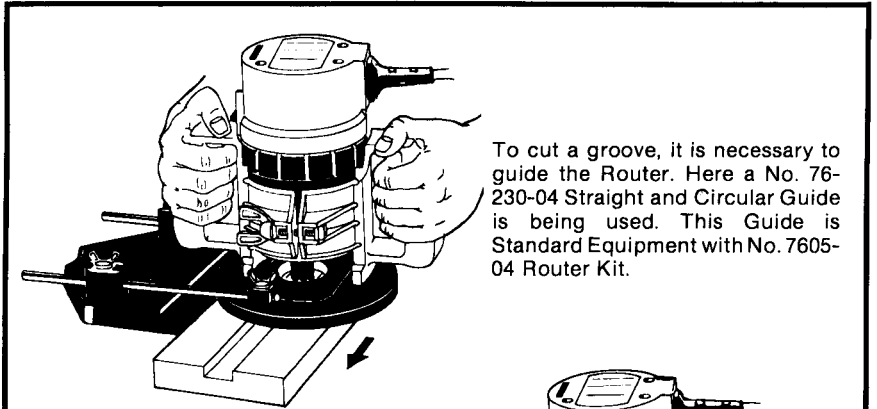

FIG. 12

To cut a groove, it is necessary to guide the Router. Here a No. 76-230-04 Straight and Circular Guide is being used. This Guide is Standard Equipment with No. 7605-04 Router Kit.

If cut must be farther from edge, a clamped wood strip or a home made T-Square works fine.

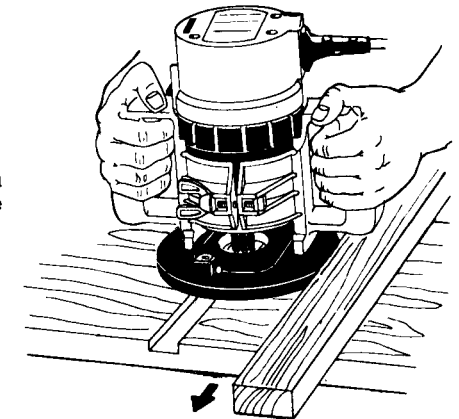

FIG. 13

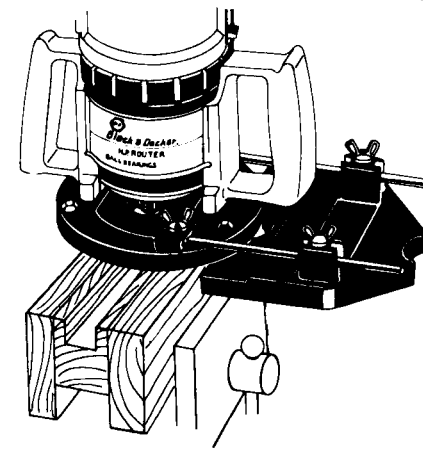

FIG. 14

To cut a groove in a narrow piece, clamp it between two other pieces which provide support for the Router base. A difficult cut made easy with the Straight & Circular Guide.

**NO. 76-230-04 STRAIGHT & CIRCULAR GUIDE**

(Standard Equipment with No. 7605-04 Router Kit; available at extra cost for Nos. 7600-04 & 7604-04 Routers.)

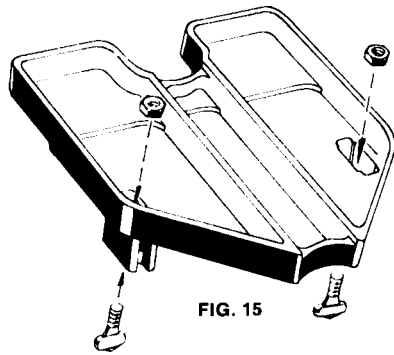

FIG. 15

The STRAIGHT AND CIRCULAR GUIDE is the most popular device used with the Router. It enables the operator to make straight, curved or angular cuts with convenience and accuracy.

TO ASSEMBLE, position nuts and screws as shown in Fig. 15 and thread screws about two turns into nuts. Do not tighten screws at this point.

Slide rods over nuts as shown in Fig. 16

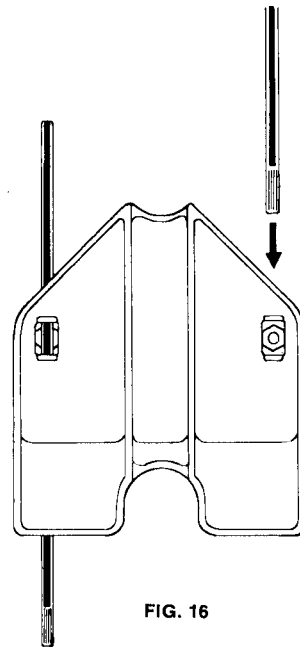

FIG. 16

TO ASSEMBLE GUIDE TO ROUTER BASE PLATE, insert hex nuts into recesses in underside of base plate (Figure 17). Place wing screws and clamps into holes and recesses on top of base plate and start screws into nuts a few turns only. Slide knurled ends of rods into channels under clamps and tighten wing screws (Figure 18).

The distance between the Router bit and the Guide is adjusted by loosening the wing screws on the Guide, sliding the Guide inward or outward on the rods, and retightening wing screws.

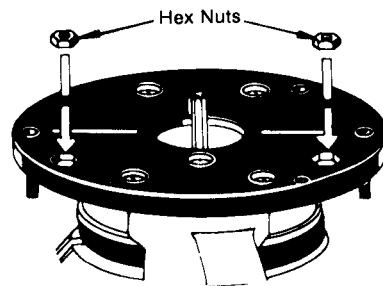

FIG. 17

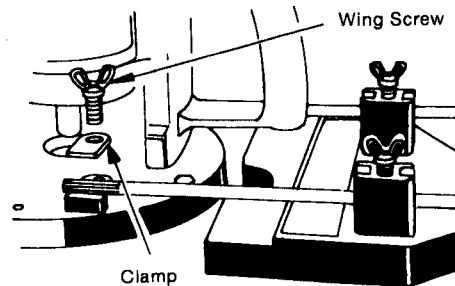

FIG. 18

**MEASURING**

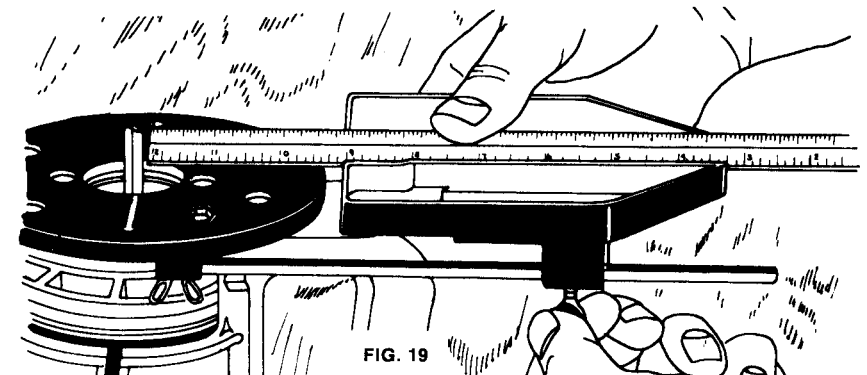

FIG. 19

For added accuracy, this B&D Router Guide features a slotted recess along its bottom that permits the insertion of a rule or scale for use in adjusting the edge of the guide in perfect relation to the cutting edge of the bit. Fig. 19 shows how this measurement is made.

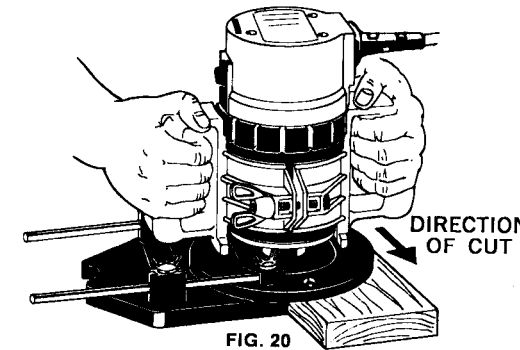

FIG. 20

**MAKING STRAIGHT CUTS**

When routing along the edge, or parallel to the edge, of straight pieces, hold Guide against the straight edge of the work as the Router is fed along cutting line as in Fig. 20.

**MAKING CURVED CUTS**

To accurately guide the Router along curved or angular edges, use two points of contact against the edge of the material. Fig. 21 illustrates this operating position to put a decorative edge around a circular table top.

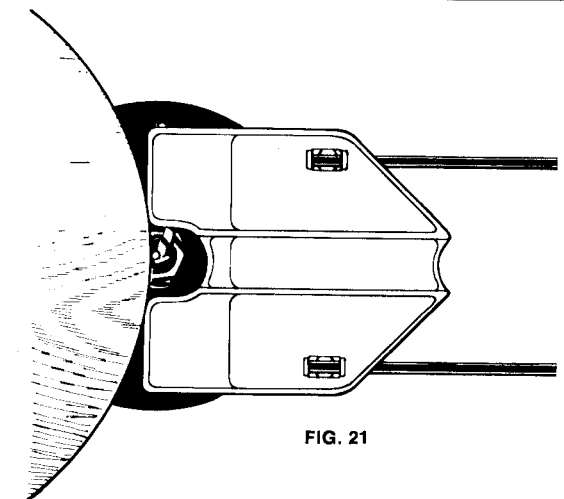

FIG. 21

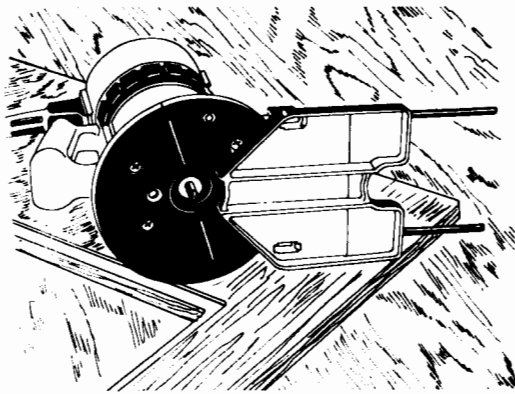

FIG. 22

### MAKING INSIDE CUTS

To rout along inside edges such as rabbeting for screens, the Straight and Circular Guide is attached in the reverse position as illustrated in Fig. 22.

### ADDING STRAIGHT-EDGE LENGTH

There are times when the length of the guide may be insufficient to give the Router ample support. When such is the case a piece of smooth lumber, about 8"-10" long and 2"-3" wide, may be attached to the front end of guide as in Fig. 23, using two wood screws. Two holes must be drilled in the straight edge of the guide for this purpose.

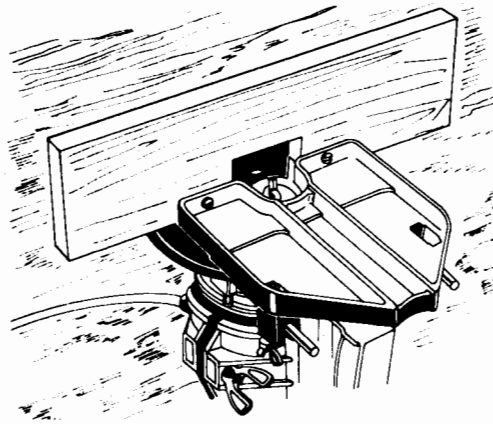

FIG. 23

FIG. 25

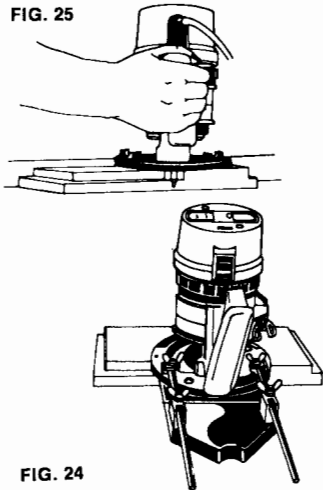

FIG. 24

### MAKING RABBET CUTS

Rabbet cuts are used for making rabbeted drawer fronts, cabinet doors and many other types of joints. Fig. 24 shows how this operation is performed, using a Rabbeting Bit. In Fig. 25 a straight bit is used, which would be placed in the collet and adjusted to the required depth of cut. The Router may be controlled by means of the Straight and Circular Guide, which is adjusted to the desired width of the rabbet cut. When making rabbet cuts, it is usually better to make them across the end grain of the lumber first, and then along the grain. This procedure tends to eliminate chipping at the edges.

## SOME TYPICAL CUTS AND JOINTS

Made With B&D Router

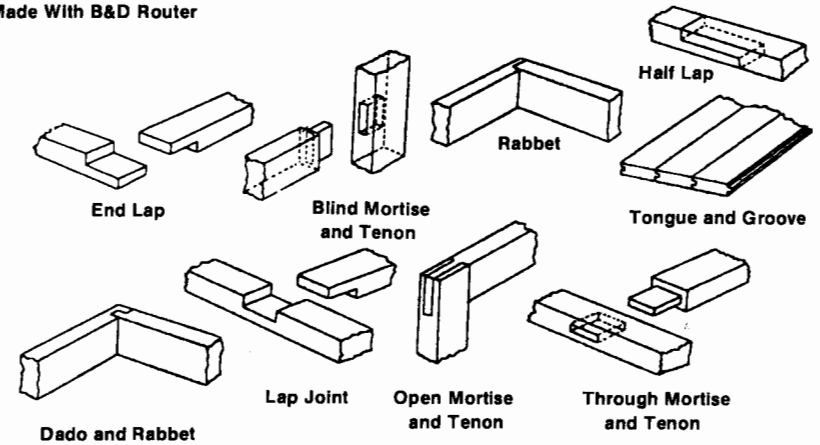

### NO. 79-013-04 ROUTERMATE\* Shaping Guide

(Available at extra cost from your dealer. Three #8-32 x 5/8" machine screws and hex nuts are required to assemble to Nos. 7600-04 or 7604-04 Routers.)

Designed for use with your Router and Black & Decker WORKMATES\*

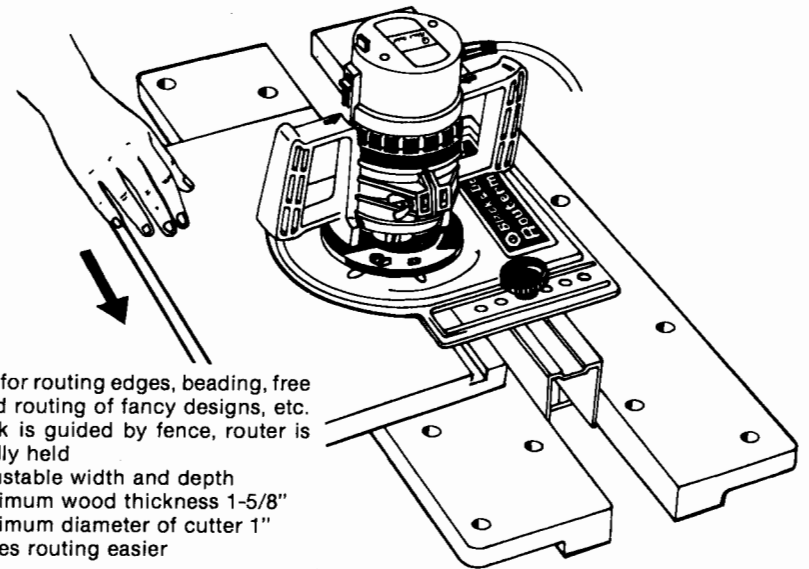

- Use for routing edges, beading, free hand routing of fancy designs, etc.
- Work is guided by fence, router is rigidly held
- Adjustable width and depth
- Maximum wood thickness 1-5/8"
- Maximum diameter of cutter 1"
- Makes routing easier

## LAMINATE TRIMMING

Laminated plastics on the market today are much too hard to be cut or shaped with ordinary router bits. Only carbide tipped cutters will produce a clean, professional quality edge without chipping.

Since plastic laminates are expensive, always practice on scrap material first. Then put your Router to the actual project.

FIG. 26

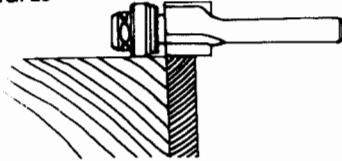

No. 76-251 Carbide Tipped Flush Trimming Cutter is shown in cutting position in Figure 26. The laminate or veneer edge can be trimmed flush and square.

FIG. 27

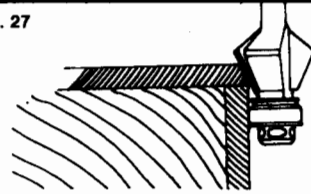

No. 76-252 Carbide Tipped 22° Bevel Trimming Cutter is shown in cutting position in Figure 27. The counter top can be neatly beveled.

Generally the laminate is precut about 3/16" larger than the final dimension to give it overhang. After the glue has hardened, the Router removes the overhang. Always make sure the ball bearing is free turning or it may burn the laminate. Remove any buildup of glue from the bearing before it causes trouble.

## ROUTER BITS AND CUTTERS

### Straight Bits

Straight Bits • Two Flutes • 1/4" Shank  
HIGH SPEED STEEL

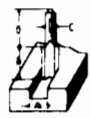

Cat. No.	A	B	C	D
•58987	1/4	5/8	1/4	1
•58988	1/4	1	1/4	1 1/4
•58989	5/16	3/4	1/4	1
•58990	3/8	3/4	1/4	1
•58992	7/16	3/4	1/4	1
•58993	1/2	3/4	1/4	1
•58995	5/8	3/4	1/4	1
•58997	3/4	3/4	1/4	1
•58998	13/16	3/4	1/4	1

### Two Flutes Carbide-Tipped

•30304	1/4	3/4	1/4	1
•30306	1/4	1	1/4	1
•30308	5/16	1	1/4	1 1/16
•30309	3/8	1	1/4	1 1/16
•30311	1/2	1	1/4	1 1/16
•30312	5/8	3/4	1/4	1 1/16
•30313	3/4	3/4	1/4	1 1/16

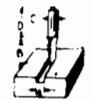

Straight Bits • Single Flute • 1/4" Shank  
HIGH SPEED STEEL

•59007	1/16	5/32	1/4	1 1/4
•59009	1/8	3/8	1/4	1 1/4
•59012	3/16	5/8	1/4	1 1/4
•59014	7/32	5/8	1/4	1 1/4
•59015	1/4	1	1/4	1 1/4

LOW COST 1/4" SHANK, SINGLE FLUTE, CARBIDE-TIPPED STRAIGHT BITS ...

76-205	1/4	5/8	1/4	1 1/8
76-206	5/16	13/16	1/4	1
76-207	3/8	7/8	1/4	1
76-209	1/2	1	1/4	1

### Grooving Bits

Veining Bits • 1/4" Shank  
HIGH SPEED STEEL

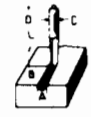

•59031	1/16	3/16	1/4	1
•59033	1/8	5/16	1/4	1
•59034	3/16	7/16	1/4	1
•59035	7/32	7/16	1/4	1

Core Box Bits • 1/4" Shank  
HIGH SPEED STEEL

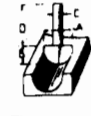

•59037	1/4	1/4	1/4	1
•59038	3/8	1/4	1/4	1
•59039	1/2	11/32	1/4	1
•59041	3/4	15/32	1/4	1

"V" Grooving Bits • 1/4" Shank  
HIGH SPEED STEEL



•59070	3/8	7/16	1/4	1
•59071	7/8	15/16	1/4	1

Hinge Mortising Bits • 1/4" Shank  
HIGH SPEED STEEL

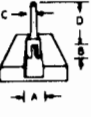

New				
Cat. No.	A	B	C	D
•59066	1/2	1/2	1/4	1 1/4

Carbide-Tipped • 1/4" Shank

•30331	1/2	5/8	1/4	1 1/2
•30411	1/2	1/2	1/4	1 1/4
•30333	3/4	3/4	1/4	1 1/2

Carbide-Tipped • 1/4" and 1/2" Shanks

•30460	1/4	5/32	1 5/8	1/4
•30461	3/8	1/4	1	1/4



Dovetail Bits • 1/4" Shank

HIGH SPEED STEEL

•59078	1/4	3/8	1/4	1 1/4
•59079	1/2	17/32	1/4	1 1/16

### Rabbeting Bits

1/4" Shank • HIGH SPEED STEEL



•59063	1/4	7/16	1/4	1
•59064	3/8	9/16	1/4	1

Carbide-Tipped • 1/4" Shank  
Ball Bearing Guide

•30480	1 1/4	1/2	1 1/3	2 1/4	1/4	3/8
--------	-------	-----	-------	-------	-----	-----

Note: Replacement ball bearing #30552 (By substituting the #30550 ball bearing—the depth of rabbet can be increased to 7/16")

### Decorating Bits

Chamfering Bits • 1/4" Shank

HIGH SPEED STEEL

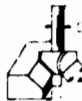

•59065	5/8	9/16	1/4	1
--------	-----	------	-----	---

Carbide-Tipped • 1/4" Shank  
Ball Bearing Guide

•30520	7/16	1	1 9/16	1/4
--------	------	---	--------	-----

Note: Replacement ball bearing #30551



Cove Bits • 1/4" Shank

HIGH SPEED STEEL

•59053	3/16	1/2	1/4	1
•59054	1/4	1/2	1/4	1
•59055	3/8	3/4	1/4	1
•59056	1/2	3/4	1/4	1



Beading Bits • 1/4" Shank

HIGH SPEED STEEL

•59048	1/8	3/8	1/4	1
•59049	1/4	1/2	1/4	1
•59050	3/8	3/4	1/4	1

### Corner Rounding Bits

Corner Round Bits • 1/4" Shank

HIGH SPEED STEEL



•59042	3/16	3/8	1/4	1
•59043	1/4	1/2	1/4	1
•59044	5/16	1/2	1/4	1
•59045	3/8	5/8	1/4	1
•59046	1/2	13/16	1/4	1

Carbide-Tipped • 1/4" Shank  
Ball bearing Guide

•30491	1/4	1/2	1 1/4	1 3/4	1/4
•30492	3/8	5/8	1 3/8	2	1/4
•30493	1/2	3/4	1 1/4	2	1/4

Note: Replacement ball bearing #30552



Ogee Bits • 1/4" Shank

HIGH SPEED STEEL

•59057	3/16	5/8	1/4	1
•59058	9/32	29/32	1/4	1



Roman Ogee Bits • 1/4" Shank

HIGH SPEED STEEL

•59060	5/32	1/2	1/4	1
•59061	1/4	3/4	1/4	1



Panel Pilot Bits

HIGH SPEED STEEL

•59072	1/4	3/4	1/4	1 5/16
•59073	3/8	7/8	3/8	1 1/8

CARBIDE TIPPED

•30350	1/4	3/4	1/4	1 1/4
--------	-----	-----	-----	-------

### Trimming Bits

#76-250 (U59113) LOW COST CARBIDE-TIPPED COMBINATION STRAIGHT & 22° BEVEL KIT

Cat. No.	A	B	C	D
76-250	3/16	7/16	1/4	1

Straight & 22° Bevel • Carbide Tipped

• 1 Flute

•30581	3/16	17/32	1/4	13/32
--------	------	-------	-----	-------



7° Bevel • Solid Carbide

•30362	3/16	3/8	1/4	1
--------	------	-----	-----	---



Flush Trim • Solid Carbide

•30361	1/4	3/8	1/4	1
--------	-----	-----	-----	---

### Trimming Cutters

NEW LOW COST CARBIDE-TIPPED COMBINATION STRAIGHT ANO22° BEVEL BIT

76-250	3/16	7/16	1/4	1
--------	------	------	-----	---

LOW COST 1/4" 2-FLUTE CARBIDE-TIPPED 22° BEVEL CUTTER WITH SCREW, WASHER & BALL-BEARING

•76-252	11/16	1/2	1/4	1 1/8
---------	-------	-----	-----	-------

Veneer Trimming Arbor

•59124	5/8	1 3/32	1/4	1
--------	-----	--------	-----	---

Oversize Ball Bearing Assembly for use with 22°, 45° Cutters.

•59125	13/16	1/4	1/4	
--------	-------	-----	-----	--



Trimming Saw • Solid Carbide

•59131	1/4	1/32	1/4	1
--------	-----	------	-----	---

22° Bevel Trimming Cutter • Carbide Tipped

•59132	57/64	3/8	1/4	
--------	-------	-----	-----	--

45° Bevel Trimming Cutter • Carbide Tipped

•59133	1	1/4	1/4	
--------	---	-----	-----	--

Flush Trimming Cutter • Carbide Tipped

•59134	5/8	3/8	1/4	
--------	-----	-----	-----	--

Use 3 items above on U59124 Arbor



### Low Cost Router Bit Sets

40% to 50% savings over buying conventional Router Bits. Each set is packed in a custom fitted storage case.

### No. 76-308 8-Piece Arbor-type Router Bit Set

Includes above Cat. Nos. 76-000, 76-064, 76-045, 76-061, 76-049 and 76-055.

### No. 76-306 6-Piece Arbor-Type Router Bit Set

Includes 76-306 6-Piece Arbor-type Router Bit Set  
Includes above Cat. Nos. 76-000, 76-064, 76-045 and 76-061.

### No. 52332 Slot and Circle Guide (Figure 28)

Equips Router for cutting evenly spaced slots and grooves, discs, holes and concentric designs. Adjusts for diameter or length from 1" to 22" in circle cutting or slot cutting.

### No. 79-013-04 Routermate

Please see page 13.

### No. 63574

Custom-fitted silver-gold plastic.

### No. 76-230 Straight and Circular Guide

Please see pages 10, 11 and 12.

FIG. 28

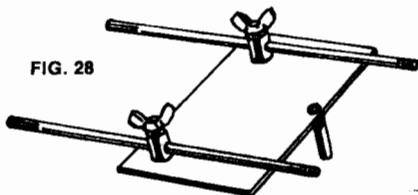

### 64895 VENEER TRIMMER GUIDE

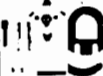

Provides precision veneer trimming with B&D Router. Includes underguide, Combination Veneer Trimming Bit, alignment pin.

### 52597 REPLACEMENT GRINDING WHEEL

For Bit and Cutter Sharpener.

• Denotes most popular router bits

\*New

**ACCESSORIES** Recommended accessories for your Router are listed in this manual. The accessories listed in this manual are available at extra cost from your local dealer, Black & Decker Service Centre, or by writing to: Customer Services, Black & Decker Canada Inc., Brockville, Ontario.

**Caution:** The use of any other attachment or accessory might be hazardous.

**CLEANING** Use only mild soap and a damp cloth to clean the tool. Many household cleaners contain chemicals which could seriously damage the plastic. Also, do not use gasoline, turpentine, lacquer or paint thinner, dry cleaning fluids or similar products. Never let any liquid get inside the tool; never immerse any part of the tool into a liquid.

**IMPORTANT** To assure product SAFETY and RELIABILITY, repairs, maintenance and adjustment, (including brush inspection and replacement) should be performed by Black & Decker Service Centres or other qualified organizations, always using Black & Decker replacements parts. When servicing Double-Insulated Tools, USE ONLY IDENTICAL REPLACEMENT PARTS.

### RAPID EXCHANGE HOME USE WARRANTY

BLACK & DECKER WARRANTS THIS PRODUCT FOR ONE YEAR AGAINST DEFECT IN MATERIAL AND WORKMANSHIP IN NORMAL RESIDENTIAL USE. THIS WARRANTY DOES NOT COVER DAMAGE RESULTING FROM NEGLIGENT HANDLING, MISUSE OR LACK OF REASONABLE CARE. PLEASE RETURN THE COMPLETE UNIT, TRANSPORTATION PREPAID, TO THE SELLER FOR FREE REPLACEMENT IF THE SELLER IS A PARTICIPATING RETAILER IN THE BLACK & DECKER RAPID EXCHANGE PROGRAM. (PROOF OF PURCHASE MAY BE REQUIRED BY THE SELLER.) THE UNIT MAY ALSO BE RETURNED TO A BLACK & DECKER SERVICE CENTRE OR AUTHORIZED SERVICE STATION FOR FREE REPLACEMENT OR REPAIR AT OUR OPTION. THIS WARRANTY DOES NOT APPLY TO ACCESSORIES.

IN RETURNING THE TOOL FOR REPLACEMENT, ALL ORIGINAL STANDARD EQUIPMENT MUST ALSO BE RETURNED (FOR EXAMPLE, CHUCK, CHUCK KEY, AUXILIARY HANDLES, CIRCULAR SAW BLADES), EXPENDABLE ORIGINAL EQUIPMENT SUCH AS SANDING SHEETS, BELTS AND DISCS AND JIG SAW BLADES NEED NOT BE RETURNED. FOR KITS AND ASSORTMENTS ONLY THE BASIC POWER TOOL WILL BE REPLACED.

THE SOLE REMEDY FOR BREACH OF THIS WARRANTY AND THE SOLE OBLIGATION OF BLACK & DECKER HEREUNDER IS THE REPAIR OR REPLACEMENT OF THE DEFECTIVE PRODUCT AT BLACK & DECKER'S OPTION. BLACK & DECKER SHALL HAVE NO LIABILITY WHATSOEVER AT ANY TIME FOR ANY PERSONAL INJURY OR PROPERTY DAMAGES OR FOR ANY SPECIAL, INDIRECT OR CONSEQUENTIAL DAMAGES OF ANY KIND HOWSOEVER ARISING.

THIS WARRANTY IS STRICTLY LIMITED TO ITS TERMS AND IS IN LIEU OF ANY KIND AND ALL OTHER WARRANTIES AND CONDITIONS, WRITTEN OR ORAL, WHETHER EXPRESS OR IMPLIED.

**Note:** THIS WARRANTY AND RELATED PROVISIONS SET OUT ABOVE MAY NOT BE APPLICABLE IN CERTAIN PROVINCES.

**Black & Decker Canada, Inc., Brockville, Ont.**