

A high performance 440/470 MHz preamp

This simple, yet effective and easy to build preamp will soup-up that 'soggy' receiver front end without costing you an arm and a leg.

TO GET THE BEST out of a UHF receiver system you need to pay attention to two important factors: front end noise figure and antenna feedline loss. Secondly, you need to worry about dynamic range and intermodulation distortion. The problem of feedline loss is tackled by buying the best low-loss coax you can afford and/or keeping the feedline length between the antenna and receiver front end to a minimum. The problem of front end noise figure has to be tackled right at the front end, at the first RF stage. Much commercially available amateur UHF band equipment, and doubtless, plenty of homebrew gear too, has receiver noise figures around 4 dB to 5 dB. This is

particularly true of older equipment.

While the majority of amateur contacts do not involve particularly weak signals, unless troposcatter DX is your 'bag', there are plenty of occasions when copying a weak signal is important (the aforesaid DX being one). On singlesideband or CW, a few dB *extra* signal-to-noise ratio can mean the difference between a contact and no contact in weak signal work; on FM it can mean the difference between a noisy, difficult to copy signal and full-quieting Q5. Hence, lowering your front-end noise figure from 4-5 dB to around 2 dB can make a world of difference.

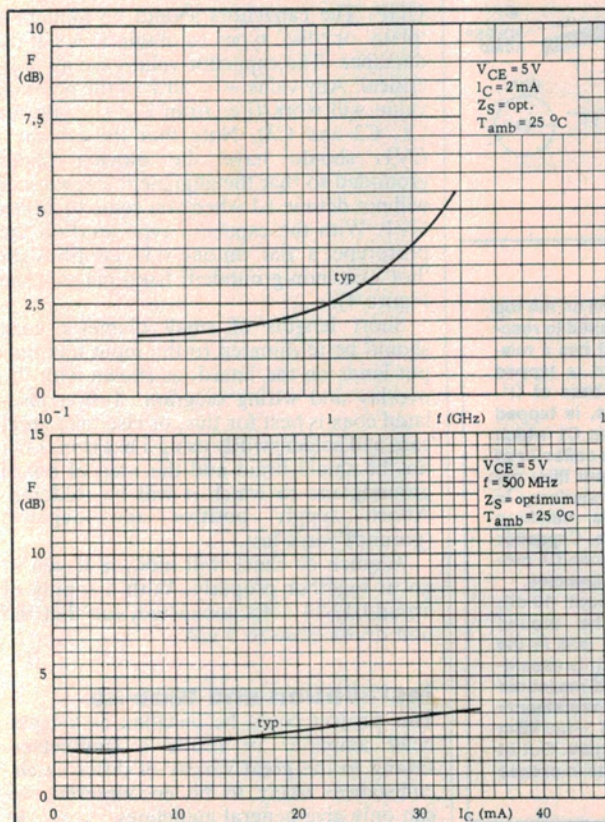
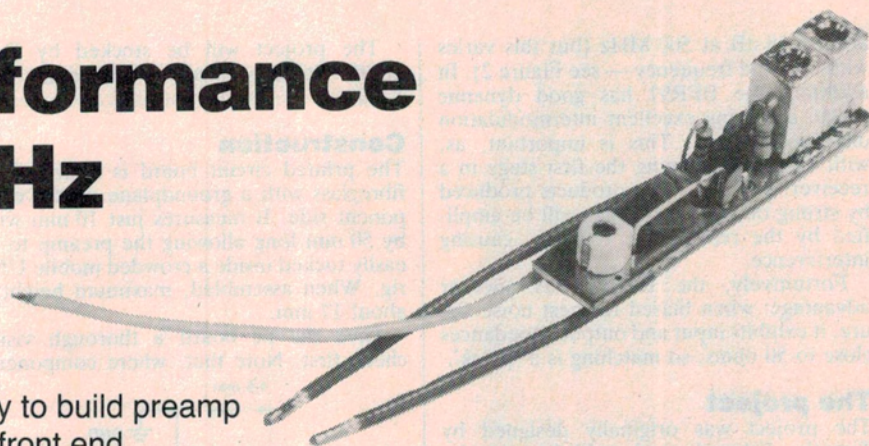
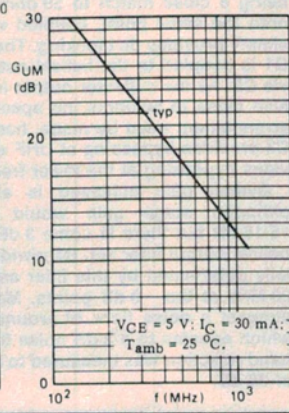

Figure 1. Typical noise figure performance of the BFR91, versus frequency (at top) and versus collector current (below it).

Figure 2. Typical RF gain of the BFR91, versus frequency. Note that gain decreases at lower collector currents.



Roger Harrison VK2ZTB

Bipolar, or go for the GaAs?

Twenty years ago, the state of the art front end either involved a varactor parametric amplifier (a rarity) or a special low noise 'lighthouse' tube like the 416B. The parametric amp could achieve vanishingly low noise figures at 430 MHz but required a high power 'pump' oscillator, and keeping it stable was tantamount to magic (requiring five arms)! The low noise tube cost an arm and a leg, required many watts of heater power and fan cooling as a result. The parametric amp could achieve noise figures around 1-2 dB, the 416B amp "better than 3 dB" when front end noise figures of 6-10 dB were common.

These days, a state-of-the-art noise figure would be less than 1 dB, readily achieved with solid-state devices, in particular, with gallium arsenide field effect transistors (GaAs FETs). Notwithstanding such fine performance, bipolar devices can achieve similar results. But, there's a catch — you have to pay handsomely for such superlative performance. GaAs FETs have one disadvantage bipolar devices do not: they are prone to electrostatic damage (ESD). For these reasons, this project uses a relatively low cost bipolar device, a BFR91.

The BFR91

While state of the art performance can be a desirable goal, it can represent overkill in many situations. As this project is primarily aimed at *improving* the performance of an existing receiver, but not at the expense of creating difficulties for the constructor/operator, a number of subtle design factors need to be considered. Cost is one. If a preamp is going to cost, say, half what the gear is worth, for the sake of a 1 dB noise figure then justifying that cost is difficult, unless you're into moonbounce. Making a worthwhile performance improvement for \$20 is much more attractive.

The BFR91 is a relatively low cost device yet exhibits good noise figure performance in the 70 cm band, achieving better than 2 dB when biased and matched correctly (Figure 1). Maximum gain is quoted at

around 18 dB at 500 MHz (but this varies with bias and frequency — see Figure 2). In addition, the BFR91 has good dynamic range, achieving excellent intermodulation distortion figures. This is important, as, with this preamp being the first stage in a receiver, any distortion products produced by strong off-channel signals will be amplified by the rest of the receiver, causing interference.

Fortuitively, the BFR91 has another advantage: when biased for best noise figure, it exhibits input and output impedances close to 50 ohms, so matching is a 'snack'.

The project

The project was originally designed by Timothy Edwards and published in the March 1982 issue of the British magazine Radio and Electronics World. Gary Crapp VK2YBX, Service Manager at Dick Smith Electronics, had successfully constructed a number following the original article and approached ETI about republishing the project. Permission was duly obtained from R. & E. W. and Gary passed on a prototype for us to play with.

The design employs the BFR91 in grounded emitter. (See circuit figure 3). The input filter is a simple tuned single wire transmission line above a groundplane (pc board). The collector is shunt-fed and the output passes via a pair of coupled helical resonators. This pre-tuned filter is made by Toko and results in a compact, low loss filter with a bandwidth of around 20 MHz at the -3 dB points. It essentially determines the overall bandpass and out-of-band rejection for the complete amplifier. It is stocked by Dick Smith Electronics and is a new listing in their 1984 catalogue; L-1850 for the 440 MHz version, L-1860 for the 470 MHz version. Simply using the L-1860 rather than the L-1850 puts the preamp on 470 MHz, making it useful for UHF CB band applications.

The project will be stocked by Dick Smith Stores, listed as catalogue No. K-6306.

Construction

The printed circuit board is double-sided fibreglass with a groundplane on the component side. It measures just 10 mm wide by 50 mm long allowing the preamp to be easily tucked inside a crowded mobile UHF rig. When assembled, maximum height is about 17 mm.

Give the pc board a thorough visual check first. Note that, where components

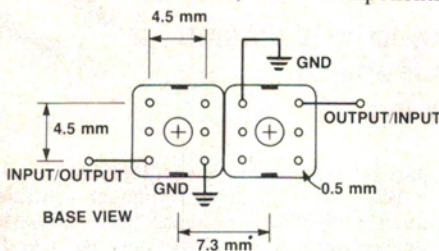

Filter pinout. Pin connections and layout of the Toko helical filter set.

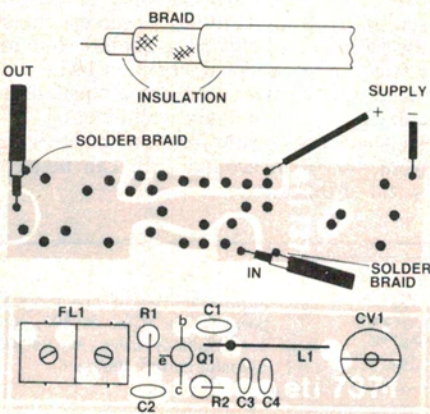

Overlay and wiring diagram.

HOW IT WORKS — ETI-737

The preamp is designed around the BFR91 which achieves a noise figure of 2 dB or better between 400 and 500 MHz and exhibits a high margin of stability. In addition, it has good dynamic range together with input and output impedances close to 50 ohms when biased for best noise figure. It is a bipolar device and hence has good immunity to electrostatic damage.

The BFR91 is employed in the grounded emitter configuration. Bias is provided by R1, direct from the collector, which is shunt fed via R2. This arrangement provides for dc bias stability with variation in temperature. If the temperature increases, the base current of Q1 will tend to increase, drawing more current via R1. However, the tendency for the base current to increase will be offset by the increase in collector current dropping the collector-emitter voltage, thus robbing the base of bias current as R1 is tied to the collector.

The input tuned circuit is a tuned, single-wire unbalanced transmission line (L1) work-

ing above a groundplane provided on the top surface of the pc board. This is tuned to resonance by CV1. This arrangement has a relatively low Q. The antenna input is tapped directly onto the line (L1). The base of Q1, being a close match to 50 ohms, is tapped onto the same point, coupled via C1 which simply provides dc blocking. The collector of Q1 is coupled to the helical output filter set via C2. As the collector output impedance is also close to 50 ohms, no special matching arrangement need be made, here. Capacitor C3 provides bypassing at UHF while C4 provides bypassing at the lower frequencies.

Overall gain achieved is about 13 dB, although stage gain would be around 15-16 dB but there is some 3 dB loss in the helical output filter set. Bandwidth is essentially determined by this filter and measured 20 MHz at the -3 dB points. Measurements suggest a noise floor of around -130 dBm which equates to a 2 dB noise figure. Out of band rejection was measured to be in excess of 35 dB.

pass through the groundplane but do not connect to it, the copper has been etched away around the hole, providing 1-2 mm clearance. Check that all holes are correctly drilled. On the reverse side, check that there are no fine 'bridges' between the copper 'lands' on the board.

Going from the overlay, fit the BFR91 first. Bend the legs straight down from the body. The emitter (middle) lead should be soldered to both the top and bottom sides of the board. Next fit the helical filter set. Orientation is unimportant but the four can tags should be soldered to both the top and bottom of the pc board.

Make up the input tuned line next. Bend up a piece of 22 gauge tinned copper wire, using the holes in the pc board as a guide. Then, insert the two ends in the board and push the wire down so that it stands 4 mm from the top surface of the pc board and solder it in place. See Figure 4. Solder a short length of wire in place for the 'tap' connection (to the antenna and BFR91 base).

The rest of the components can now be mounted and soldered in place. Make sure they are all well-seated down on the board to minimise lead inductance. Note that the two resistors are mounted upright.

I should make a note here in passing about the resistors and capacitors. It is important that low inductance types be used, otherwise you're likely to experience some strange results. Most modern low-to-medium value carbon film and metal film resistors rated at 1/2W or less have relatively low inductance and self-capacitance at UHF. The capacitors should be miniature 'plate' or 'disc' types to obtain low self-inductance. The capacitor values are all non-critical. Any value +/- 50% of the nominal value will work (i.e. from 27p to 100p for C1, C2 and C3). Note that the trimmer, CV1, should have the moving plates grounded so that the alignment screwdriver will not detune L1 when you come to adjust CV1. With the capacitor type used on the prototype, a 'flat' on one side identifies the 'hot' (i.e. non-grounded) fixed plates. (See Figure 4).

Short lengths of small diameter coax should be terminated to the input and output lands on the board, as shown with the overlay and wiring diagram. Teflon insulated coax is best for this, or else take great care and solder swiftly using a hot iron. First tin the shield braid and the area of board groundplane to which it will be soldered. Attach supply positive and negative (ground) wires last.

A quick dc check will indicate if you've got it together properly. With a supply of around 12-14 volts connected, see that the unit draws close to 5 mA.

Installation and tune-up

This project could be installed as a mast-head amplifier or inside a transceiver. Owing to the great variety of differing circumstances likely to be encountered, we can only give general guidelines. ▶

PARTS LIST — ETI-737

- Resistors.....all 1/4W, 5%
 R1.....47k
 R2.....1k
 (Resistors should be carbon or metal film types, e.g: Philips CR25 or MR16, respectively)
Capacitors
 C1, 2, 3.....68p min. ceramic
 C4.....1n min. ceramic
 CV1.....1-20p min. trimmer
Semiconductors
 Q1.....BFR91 or BFR91A
Miscellaneous
 FL1.....Toko helical filter set, 252MX-1506A/7HW for 440 MHz (D.S.E. L-1850) or 252MX-1507A/7HW for 47 MHz (D.S.E. L-1860).

ETI-737 pc board (double-sided G10 fibreglass); length of 22g tinned copper wire; length of RG174/U 3 mm diameter 50 ohm coax (preferably teflon dielectric); hookup wire, etc.
Price estimate: \$19-\$21

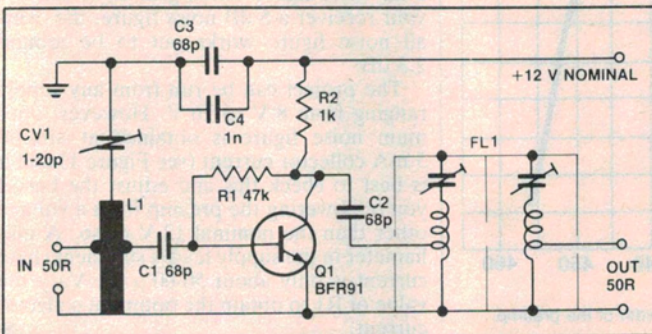
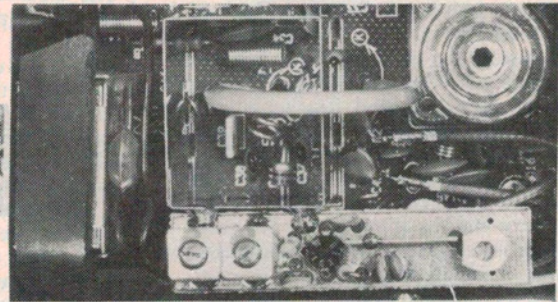

Figure 3. Circuit of the preamp.

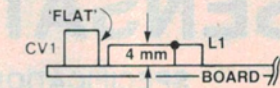

Figure 4. Showing construction of the input tuned line, L1 and orientation of the tuning trimmer, CV1.

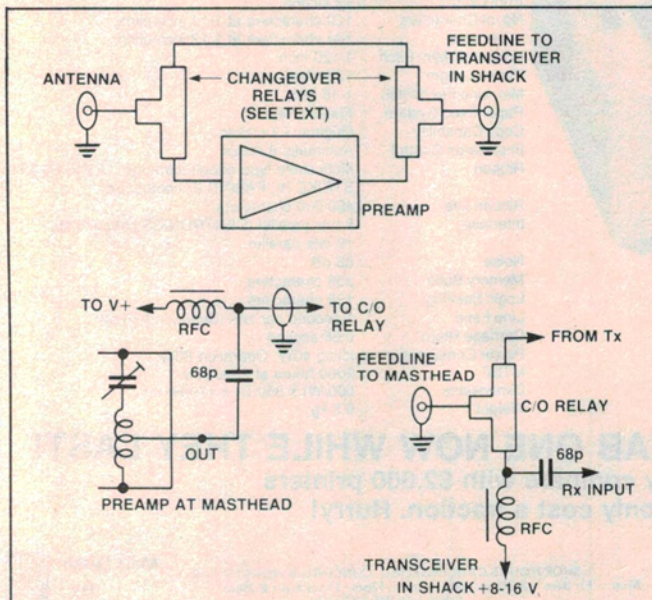

Figure 5. Showing typical installation as a masthead amplifier. Arrangements for dc feed via the coax shown below.

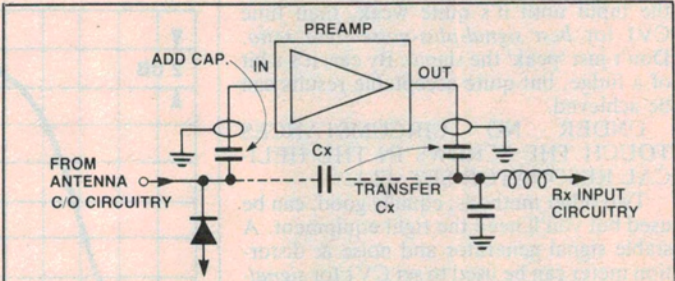

Figure 6. Showing typical installation inside a transceiver. Just insert it in place of the input coupling capacitor between the antenna changeover circuitry and RF stage input. Above. Photograph of the preamp installed in a common UHF rig, according to the circuit principle shown here.

FILTERS - DIPLEXERS - MULTICOUPLERS 40-960 MHz

- * high efficiency resonators
- * welded aluminium construction
- * invar temperature compensation
- * multicouplers custom-built
- * professional quality
- at reasonable prices
- * fastest deliveries in the west



KENSOR PTY. LTD.
 12 Hehir Street, Belmont 6104,
 West Australia
 Telephone : 4782333 Telex : AA95914

Project 737

In a masthead installation, apart from the obvious weather and grounding considerations, the unit has to be switched out of the line when transmitting. Even if only moderate powers are used, changeover relays of the type which ground the unoperated connection should be used. The supply voltage can be either via a separate wire or the coax centre conductor, as illustrated in Figure 5.

In a transceiver, the unit should be installed between the antenna changeover circuitry and the input of the RF stage. A typical input circuit and the modification is shown in Figure 6.

For a preliminary tune-up, you can pick a local signal (e.g. a beacon), attenuate it at the input until it's quite weak, then tune CV1 for *best signal-plus-noise/noise ratio*. Don't just 'peak' the signal. By ear, it's a bit of a fudge, but quite acceptable results can be achieved.

UNDER NO CIRCUMSTANCES TOUCH THE SCREWS IN THE HELICAL RESONATOR SET, FL1.

Two other methods, equally good, can be used but you'll need the right equipment. A stable signal generator and noise & distortion meter can be used to set CV1 for *signal-plus-noise/noise ratio* at a given distortion or for minimum distortion (that's what your goal is, after all). Alternatively, a stable noise source and an ac voltmeter can be used to set CV1 for *minimum noise figure*. The necessary equipment and technique for this is described in the ARRL's *Radio Amateurs' VHF Manual*.

Performance

The measured bandwidth was 20 MHz at the -3 dB points (Figure 7). Mid-band gain was 13 dB. As for dynamic range, the output -1 dB compression point was -3 dBm (0.5 mW), the output saturating at -2 dBm (0.7 mW). When installed in a UHF rig that gave a sensitivity of 1 μ V for 12 dB SINAD, sensitivity improved to 0.25 μ V for the same SINAD.

The results you get will entirely depend on the noise figure of the existing front end. Note that you won't achieve an overall noise figure equal to the preamp's noise figure because the existing front end also

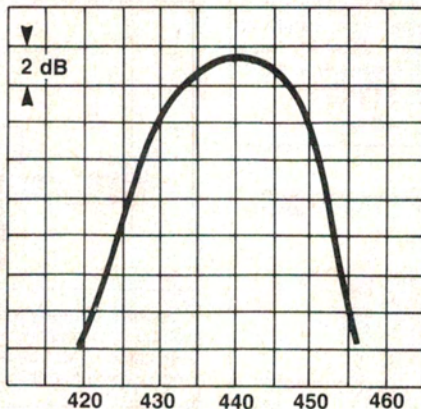

Figure 7. Measured bandwidth of the preamp.

contributes some noise. The overall noise factor of a receiving system is given by:

$$F = f_1 + \frac{f_2 - 1}{G_1} + \dots + \frac{f_n - 1}{G_n \dots G_2 G_1}$$

where f_1 is the noise factor of the first stage
 f_n is the noise factor of the n^{th} stage
 G_1 is the gain of the first stage
 G_n is the gain of the n^{th} stage

It's obvious from this equation that the first stage largely determines the noise figure and, if the gain of this and succeeding stages is greater than one, the denominator of each term becomes greater. Thus, the numerical value of the terms beyond the second or third stage rapidly approaches zero and can be ignored.

As an example, if your preamp has a 2 dB noise figure and a gain of 13 dB and your receiver a 5 dB noise figure, the overall noise figure works out to be around 2.3 dB.

The project can be run from any supply ranging from 8 V to 16 V. However, optimum noise figure is obtained at around 5 mA collector current (see Figure 1) and it is best to check this and adjust the bias if you're powering the preamp from a voltage other than the nominal 12 V or so. A milliammeter in the supply lead is sufficient (base current is only about 50-60 μ A). Vary the value of R1 to obtain the optimum collector current.