

# What's On WWV

*Demysticizing what you hear on WWV and WWVH broadcasts and a couple of circuits that can make your reception more exciting*

By E. Thomas Hitt III

You can get more than just the voice-announced time of day (Coordinated Universal Time) when you tune to WWV or WWVH on your shortwave radio. You have probably tuned to WWV or WWVH many times to get Coordinated Universal Time, but you probably wondered about what those other whistles, beeps and messages you heard meant. In this article, we will explore just what is on WWV (and WWVH). We will also look at a couple of circuits you can build to help you in further understanding lesser-known features of the broadcast signals.

## Time & Standards

Coordinated Universal Time, also

known as UTC, this is an internationally agreed-upon standard time that is essentially, but not quite, the same as Greenwich Mean Time (GMT) or Zulu (Z). UTC is based on atomic time standards that run at a very constant rate. In fact, these atomic clocks run at a more constant rate than the rotation of the Earth. In contrast, GMT is based on the rotation of the Earth.

The actual standard for time based on the rotation of the Earth is called UT1 and is determined from astronomical observations. UTC and UT1 are usually within less than 1 second of each other. A yearly variation in the difference between the two amounts to about  $\pm 30$  milliseconds, which can be ignored by most people. There also exists a continuous "creep" in the difference between the two

standards because of the slowing of the Earth's rotation. When this slowing causes the difference to reach 1 second, a "leap second" is added to UTC to keep it close to UT1.

Leap seconds must be added every year or so, usually on December 31 or June 30. International agreement makes these dates the first choices, with March 31 and September 30 and any other month the second and third choices. An example of a leap second would be to add 1 second starting at 23:59:60 on June 30 and ending it at 0:00:00 on July 1. Anything that occurs during the leap second is considered to have occurred in June.

Atomic time standards used by WWV are based on the frequency produced by transitions of electrons between two specific quantum levels in cesium-133 atoms. The second

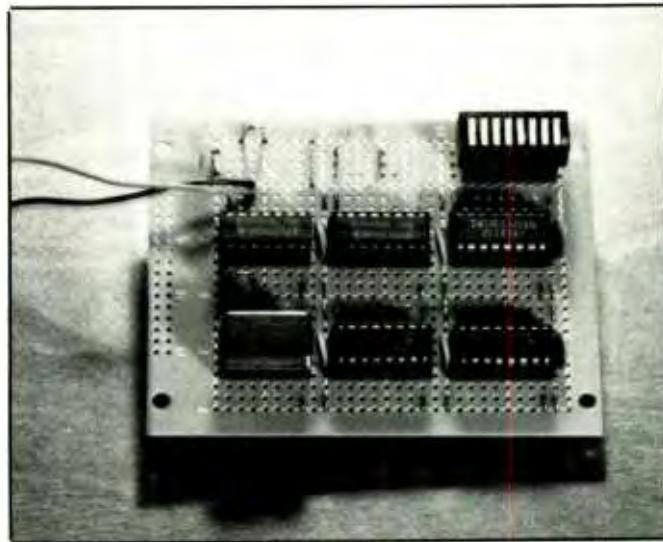
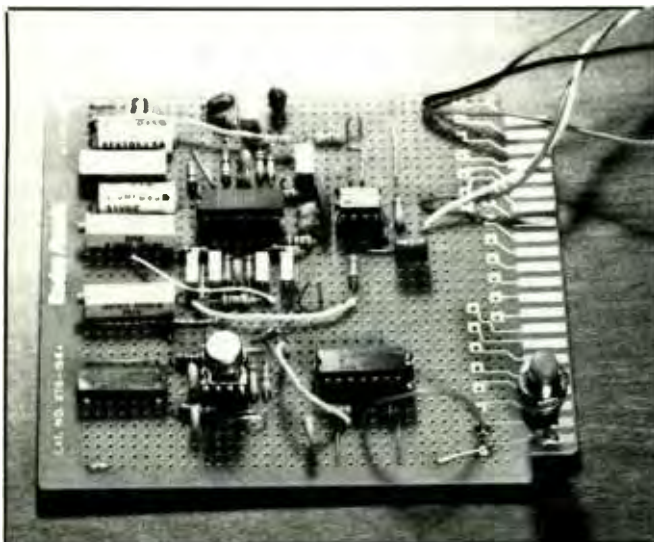

Fig. 1. Two projects built by the author to aid in viewing WWV signals on the screen of an oscilloscope: (A) a band-pass filter and (B) a 1-Hz oscillator.

measured by this type of clock was defined in 1967 by the 13th General Conference on Weights and Measures as the duration of 9,192,631,770 periods of the radiation corresponding to the transition between the two hyper-fine levels of the ground state of the cesium-133 atom. This type of clock is a primary standard and does not have to be checked against another clock. The timekeeping accuracy of the cesium-beam clock is better than one part in  $10^{12}$  (one part in a trillion), or something like comparing a dollar to the national budget.

If you need time based on the rotation of the Earth accurate to within 0.1 second and do not want to bother with decoding a time code sent by WWV or WWVH on a 100-Hz sub-carrier, you can convert UTC to UT1 by listening to the WWV broadcast and counting the double second ticks. The number of double ticks is the number of tenths of seconds that UTC differs from UT1. If the correction is to be added to UTC, there will be up to eight double ticks, starting with the first second of the minute. If the correction is to be subtracted, the double ticks start with the ninth second. For example, if only the first second tick is a double, then 0.1 second is added to UTC to obtain UT1. If the ninth through eleventh ticks are doubled, then 0.3 second is subtracted from UTC.

The second "ticks" you hear are really short tone bursts. WWV sends five cycles of 1 kHz (six cycles of 1.2 kHz for WWVH) at the start of each second, with the exception of the 29th and 59th seconds. The rising edge of the first cycle of the tone marks the beginning of the second. There is a silent period from 10 milliseconds before to 25 milliseconds after each second pulse to keep the other signals sent by WWV from interfering with the second pulses.

Along with the second pulses, two other short tone bursts are worth knowing about—the minute and hour identifiers. The beginning of a

minute is indicated by a 1-kHz tone (1.2-kHz tone for WWVH) that lasts for 800 milliseconds. Both WWV and WWVH identify the start of the hour by a 1.5-kHz tone for 800 milliseconds. The rising edge of the first cycle of these pulses, like the second pulses, corresponds to the start of their respective time periods. These tone bursts can be filtered out of the broadcast, be detected and then be used to trigger events that one wishes to occur on the hour or on the minute.

Three other audio frequencies are broadcast by WWV. For most of the hour, 500- and 600-Hz tones are sent in the first 45 seconds of alternating minutes. WWV sends the 600-Hz tone during even-numbered minutes and WWVH sends them during odd-numbered minutes. The third tone, 440 Hz, is sent for one 45-second period during each hour. This tone is sent by WWV during the third minute after the hour and by WWVH during the second.

These 500- and 600-Hz tones are occasionally preempted for voice announcements to give information on severe weather conditions, geophysical alerts and status reports on the Omega navigation system. Also, station ID transmissions are given on the hour and half hour.

Severe weather information from WWV is transmitted during minutes 8, 9 and 10 and is for the Atlantic and the eastern North Pacific. WWVH provides coverage for the eastern and central North Pacific during minutes 48, 49 and 50. This information is provided because international agreements give the United States responsibility for providing storm warnings in these areas.

These geophysical alerts (Geo-alerts) are broadcast by WWV during minute 18 and give information that is useful in determining radiowave propagation conditions. Geoalerts give such information as:

(1) The 1700Z solar flux measured at Ottawa, Canada at 2,800 MHz and is an indication of solar activity.

(2) The estimated A value for Fredericksburg, VA, which indicates the activity of the earth's geomagnetic field.

(3) The current K-index at Boulder, CO, which is another measure of geomagnetic field activity.

(4) The solar-terrestrial conditions for the previous 24 hours.

(5) The forecast for the next 24 hours.

Omega status information is broadcast by WWV during minute 16 and by WWVH during minute 47. This information is concerned with operation of a long-range navigation system that uses frequencies between 10 and 14 kHz to provide position information worldwide. The information given has to do with which stations are operating, planned maintenance, etc., and is useful to ships and some military aircraft that use the Omega system for navigation.

There are some minutes during which no audio tones or voice announcements are broadcast. These minutes generally correspond to the minutes when the other station is transmitting a voice announcement and is done to keep the tones from WWV from interfering with WWVH voice announcements, and vice-versa. If conditions are right and you listen during one of the quiet minutes, you can hear announcements coming from the other station. Elimination of the audio tone keeps it from interfering with an important voice announcement on the other station.

Another example of trying to keep the two stations from interfering with each other is the timing of the voice announcement of the UTC time. WWVH is the first to make the announcement, starting at 45 seconds and ending at about 50 seconds into the minute. The WWV announcement starts at 52.5 seconds and ends a few seconds before the minute. During the time period when the announcements are being made, both stations cease transmission of the 500- and 600-Hz tones. When propa-

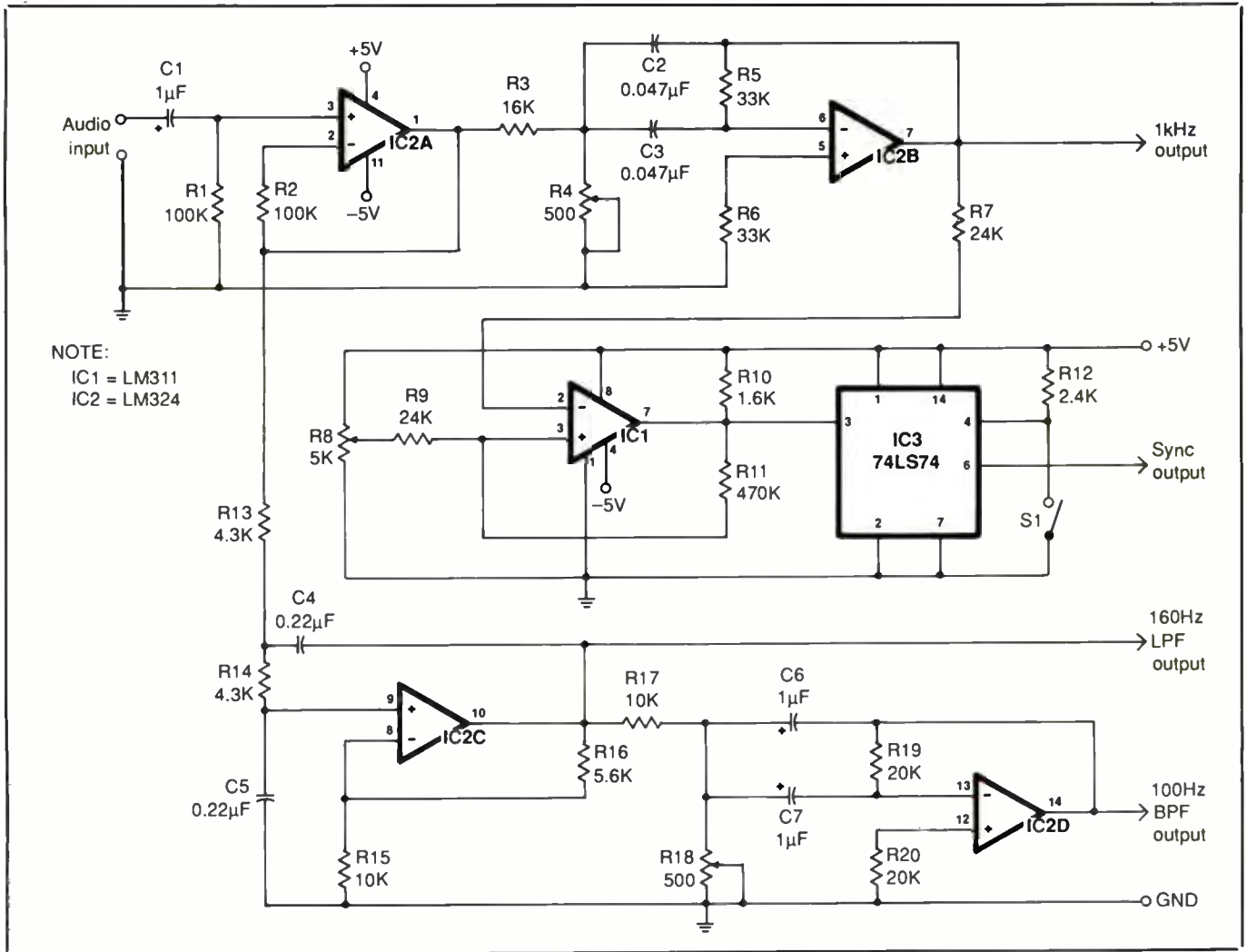

Fig. 2. Schematic diagram for bandpass filter circuit.

gation conditions are right, you can hear the female voice make the announcement from WWVH first and then the male voice from WWV.

The same atomic clocks that keep time at WWV are used to control the frequencies of the transmitters and audio tones. The r-f and modulation frequencies transmitted are guaranteed to be accurate to within one part in  $10^{11}$  and are usually better.

The frequencies you receive are not that accurate because of variations in the propagation path. A change of just 1 foot in path length in 1 second changes transit time by about a nanosecond or one part in

$10^9$ , which is 100 times greater than the variations in the transmitted signal. Even with this reduced accuracy, the received hf signal is good enough to calibrate most receivers and oscillators.

If you have a frequency reference that can approach an accuracy of one part in  $10^{11}$  and want to compare it with the National Institute of Standards and Technology (NIST, used to be called the National Bureau of Standards) reference, you can use the transmissions from hf station WWVB.

This station is also located in Fort Collins, CO, and transmits on a frequency of 60 kHz. Because propaga-

tion is more constant in this part of the spectrum, frequency variations caused by changes are smaller.

Even so, it is necessary to track the phase of the signal for hours or days to be able to compare your oscillator with theirs. This is not a trivial task, but it can give accuracies of one part in  $10^{11}$ . Fortunately, most of us have no need for anything like the accuracy available from WWVB and can stick to using WWV and WWVH.

One of the more interesting and potentially useful signals sent by WWV and WWVH is the time code. This is transmitted using a 100-Hz subcarrier with a code that consists

## WWV Time Standard Plug-In for PCs

A plug-in Model CTS-10 WWV time standard card from Coordinated Time Link, Inc. synchronizes the clocks in IBM PCs/XTs/ATs and compatible computers to the world atomic time standard from WWV/WWVH National Institute of Standards and Technology (formerly the National Bureau of Standards) radio signals to any application running on the PC to provide the correct time. The CTS-10 plugs directly into an open slot in a PC to maintain the computer's clock. It incorporates a radio receiver, digital signal-processing circuitry, bus interface and several proprietary applications on a single board and runs under DOS 2.1 or later. Menu-driven software simplifies installation.

The CTS-10 automatically accommodates daylight saving time, leap year, leap seconds and other anomalies. Time-zone selection, 12/24-hour selection, adjustable on-screen display and color selection are provided. On-board battery back-up maintains correct time during power interruptions, and remote diagnostics (via modem) and a built-in log provide evaluation and troubleshooting capabilities. The user also has a choice of Standard Time or Universal Coordinated Time selection.

Time accuracy is rated to be within 20 milliseconds of Coordinated Universal

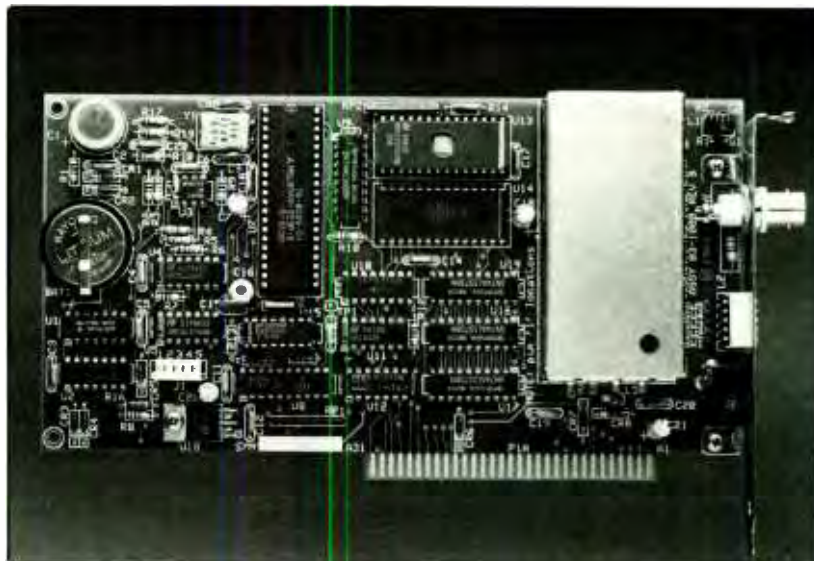

Time, and time to acquire is 3 minutes minimum with strong WWV signals, with 5 minutes typical. The receiver is a single-conversion, crystal-controlled superheterodyne design that operates on 10 MHz with a sensitivity of less than 0.2 microvolt input via its 50-ohm BNC antenna connector.

For interfacing the CTS-10 to the PC, there are 32 port addresses from which to choose, ranging from 207 to 3F7 and four

interrupt levels (IRQ3, IRQ4, IRQ5 and IRQ7). Operation of the card is in polled mode.

Power requirements for the plug-in card are 100 milliamperes at 12 volts dc, from the computer's bus or an external power supply. The card measures 8"L x 5"H x 1"D. Price for the CTS-10 is \$225, and it is available from Coordinate Time Link, 3442 De La Cruz Blvd., Santa Clara, CA 95054 (tel.: 408-980-1305).

of tone bursts of 17 and 47 cycles of 100 Hz to represent 0 and 1, respectively. The actual time data is sent in binary-coded-decimal (BCD) format. Data rate is one pulse per second with the least-significant bit (LSB) of each BCD digit sent first.

One complete frame of the time code is sent each minute. The code contains UTC time, day of the year, whether or not daylight savings time is in effect and a correction for UT1 time. The encoded time is the time at the start of the frame so that once the complete frame is decoded, about 1 minute must be added to obtain current time. The code is sent in groups

consisting of nine data and a position identifier pulses. Data pulses are usually divided into two BCD digits that are separated by a dummy pulse that carries no information.

### *Examining the Signals*

If you are interested in taking a closer look at the second, minute, hour and time code pulses with an oscilloscope, we present here simple circuits you can build to be able to see them better. You might even be able to think of useful things to do with some of these signals. Construction is fairly simple, as can be seen in Fig. 1.

The first circuit, shown schematically in Fig. 2, is a second-order 1-kHz active bandpass filter. This filter has a bandwidth of 200 Hz to make it an approximately matched filter for the 5-millisecond long seconds pulses. Using the radar rule of thumb about the bandwidth being the reciprocal of the pulse-width, a 200-Hz bandpass filter is matched for a 5-millisecond pulse. This filter allows you to use the seconds pulses for synchronizing an oscilloscope.

To use the Fig. 1 circuit, connect the output of the filter to an oscilloscope to view the seconds pulses. Adjust *R2* to tune the filter for the largest

signal excursion on the oscilloscope screen. The filtered pulses do not look like the pulses sent by WWV; they have an approximate Gaussian shape caused by the filtering.

A digital storage oscilloscope would be ideal for examining the seconds pulses, but you can see them reasonably well on a standard oscilloscope. The main advantage of a digital oscilloscope is that it can display what happened just before the sweep was triggered.

The next filter is a 160-Hz second-order Butterworth low-pass section followed by a 100-Hz bandpass section that has a Q of about 6. This filter separates the time code from the other tones. The Q of the bandpass section is fairly low to help reduce ringing of the filter. The schematic configuration for this filter is shown

in the lower part of Fig. 2. To tune this filter, you adjust *R18* for maximum output.

If you use the filtered seconds pulses to synchronize your scope and examine the 100-Hz filter output, you will see the three different 100-Hz pulses lengths. You will also see that the first 30 milliseconds, three cycles of 100 Hz, is suppressed. Depending on reception conditions and other tones that may be present, you might get a better picture of the 100-Hz time-code pulses at the output of the low-pass filter, rather than at the output of the bandpass filter. Because the low-pass filter has a wider bandwidth than the bandpass filter, time-code pulses look more like square bursts of 100 Hz.

Another circuit you will find useful for examining WWV signals is a

1-Hz generator that can be synchronized to the seconds pulses. With this circuit, you can make a standard oscilloscope produce the same type of display of the seconds pulses as you would get from a digital oscilloscope.

The schematic diagram for such a circuit is shown in Fig. 3. This circuit uses a 4-MHz crystal oscillator that is divided to 100 Hz with a string of counters. The decision to use a 4-MHz oscillator was based on crystals I had on hand and selecting a frequency that could be easily divided to 100 Hz with binary and decade dividers. You can use a crystal with a different frequency and modify the divider to obtain a 100-Hz output.

Once it is obtained, the 100-Hz signal goes to the 74LS160A decade counters that are the last two stages in the chain. These counters produce

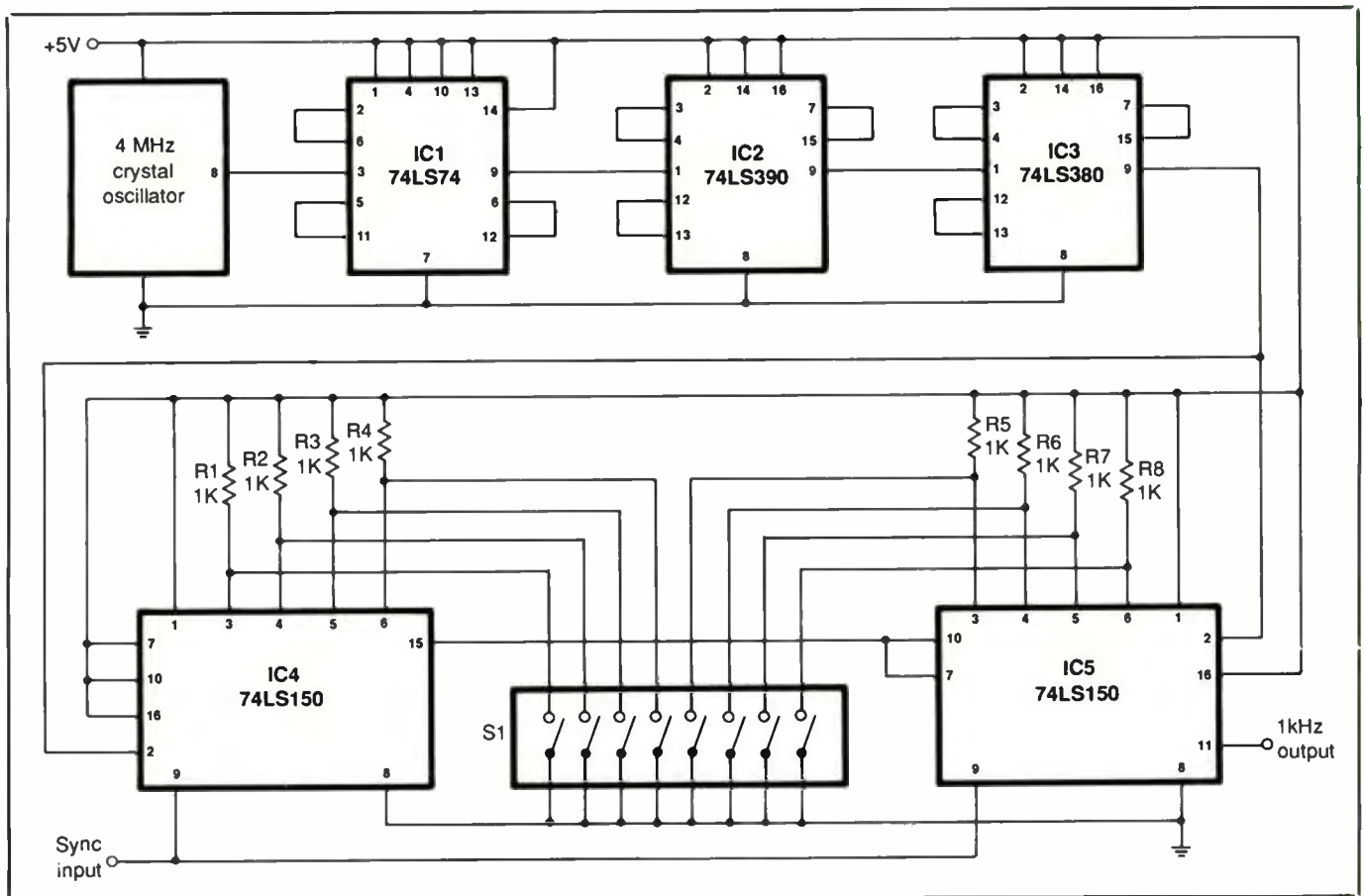

Fig. 3. Schematic diagram for 1-Hz oscillator circuit.

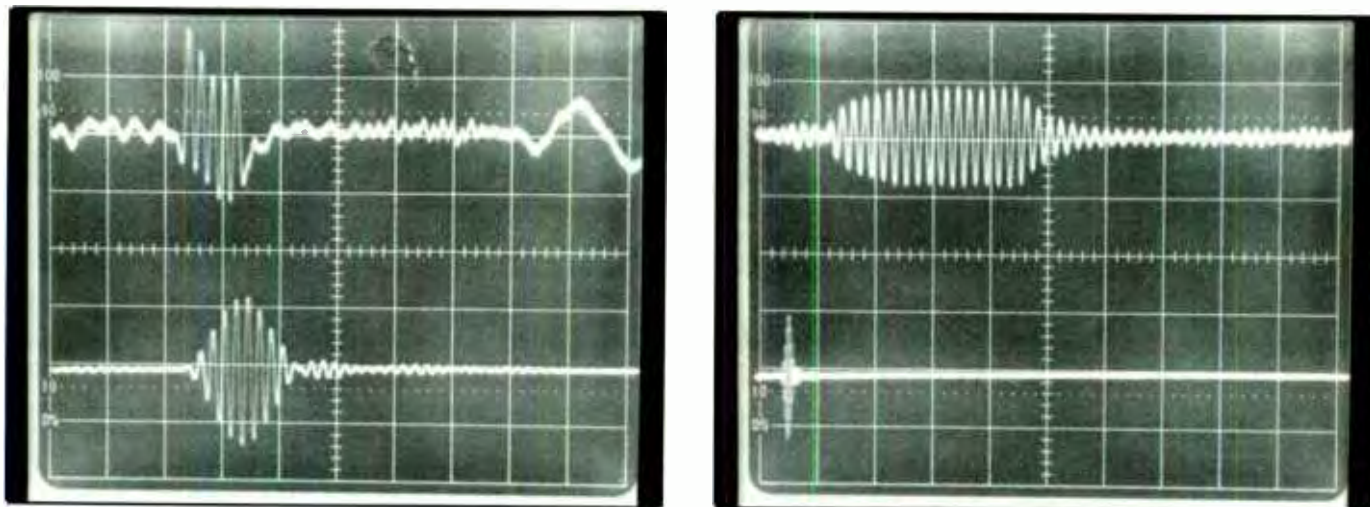

Fig. 4. Screen photos taken using bandpass and oscillator circuits with scope sweep controls set for (A) 5 ms/div. and (B) 50 ms/div.

the 1-Hz output and can be started at a preset count determined by DIP switch *S2*. The crystal oscillator is stable enough to keep the 1-Hz output of the timing generator close to the timing of the seconds pulses for many minutes.

Synchronization of the 1-Hz generator to the seconds pulses is handled by a comparator and D-type flip-flop shown at the top in Fig. 2. The SYNC OUT of the flip-flop connects to the Preset Enable (PE) input of the two 74LS160As and is normally high. This allows the counter to count cycles of the 100-Hz input from the rest of the divider chain. If pushbutton switch *S1* is pressed and released, the output of the flip-flop goes low and causes the 74LS160As to halt and to load the number set via DIP switch *S2*.

When the next seconds pulse arrives, it is converted into a TTL pulse train by the comparator and fed to the Clock (CK) input of the flip-flop. Clocking the flip-flop causes the output to go high again, allowing the 74LS160As to start counting.

If *S2* is set to load 0001 into the first counter and 0000 into the last, it will take 0.99 second (99 cycles of 100 Hz) for the counter to reach a count of 00 again. At this point, output QD

goes low and triggers the oscilloscope. The next seconds pulse arrives 10 milliseconds later and is easily visible on the oscilloscope. Potentiometer *R1* sets the threshold of the comparator so that it responds to the high level of the seconds pulses but not to low-level random noise.

Viewing the signals from WWV with the 1-Hz generator synchronizing the oscilloscope gives you a better idea of what the signals are like. Fig. 4(A) was made with a sweep speed of 5 milliseconds per division. The upper trace shows the seconds pulse directly from the receiver, lower trace the filtered pulse. You can see that the transmitted pulse is square and the filtered one is Gaussian in shape.

The upper trace in Fig. 4(A) also shows the start of a time-code pulse at the far-right. The photo in Fig. 4(B) was made with a sweep speed of 50 milliseconds per division. The upper trace here shows a filtered time-code pulse, the lower trace a filtered seconds pulse.

If you are interested in WWV trivia, the station went on the air in 1923 and is located at 40° 40' 49" N, 105° 02' 27" W, more commonly known as 2000 East County Rd. 58, Fort Collins, CO 80524. The antennas used at WWV are omnidirectional vertical

half-wave dipoles radiating 10 kW on 5, 10 and 15 MHz, and 2.5 kW on 2.5 and 20 MHz.

WWVH went on the air in 1948 and is located at 21° 59' 26" N, 159° 46' 00" W. Its mailing address is P.O. Box 417, Kekaha, Kauai, HI 96752. Radiated power for WWVH is 5 kW on 5 MHz and 10 kW on 5, 10 and 15 MHz. The antennas at WWVH for 5, 10 and 15 MHz are vertical half-wave dipole arrays fed to give cardioid patterns with maximum radiation to the west. The antenna for 2.5 MHz is omnidirectional.

I hope the foregoing has given you a better idea of what is transmitted by WWV and some ideas about making use of the time and frequency information. If you are interested in learning more about WWV, I recommend two references: *Reference Data for Radio Engineers* (Howard W. Sams) and NBS Special Publication 432 titled "NBS Time & Frequency Dissemination Services." The Sams book is probably available in your local library; the NBS publication can be obtained from the U.S. Government Printing Office in Washington, DC or from Frequency-Time Broadcast Services Section, Time and Frequency Division, NIST, Boulder, CO 80302. **ME**