

SWITCH-MODE DRIVERS FOR SOLENOID DRIVING

This design guide describes the operation and applications of the L294 and L295 switch-mode solenoid drivers. Integrating control circuitry and power stage on the same chip, these devices replace complex discrete circuits, bringing space and cost savings.

Many applications, particularly in computer peripherals, require a high power, fast solenoid driver circuit. In the past these circuits have been realised with discrete components because the high powers required precluded the use of monolithic technology.

SGS-THOMSON Microelectronics has overcome this problem with a new high power bipolar technology that uses an innovative implanted isolation technique. This technology is used to fabricate two switchmode solenoid driver chips, the L294 and L295, which both incorporate high power output stages and control circuitry. Both circuits are designed for efficient switchmode operation and are mounted in Multiwatt [®] plastic package.

THE L294 SOLENOID DRIVER

The L294 is designed for solenoid driving applications where both very high speed and high current are essential; needle and hammer driving in printer mechanisms, for example. It delivers 4 A with supply voltages up to 46 V, handling effective powers up to 180 W.

Shown in figure 1, the L294 is controlled by a TTL - level logic input and the peak load current is programmed by a reference voltage applied to the pin labelled V_i .

Internal switchmode control circuitry regulates the solenoid current by turning the output stage on and off repeatedly to keep the load current between the

Figure 1 : Internal Block Diagram of the L294 Switchmode Solenoid Driver.

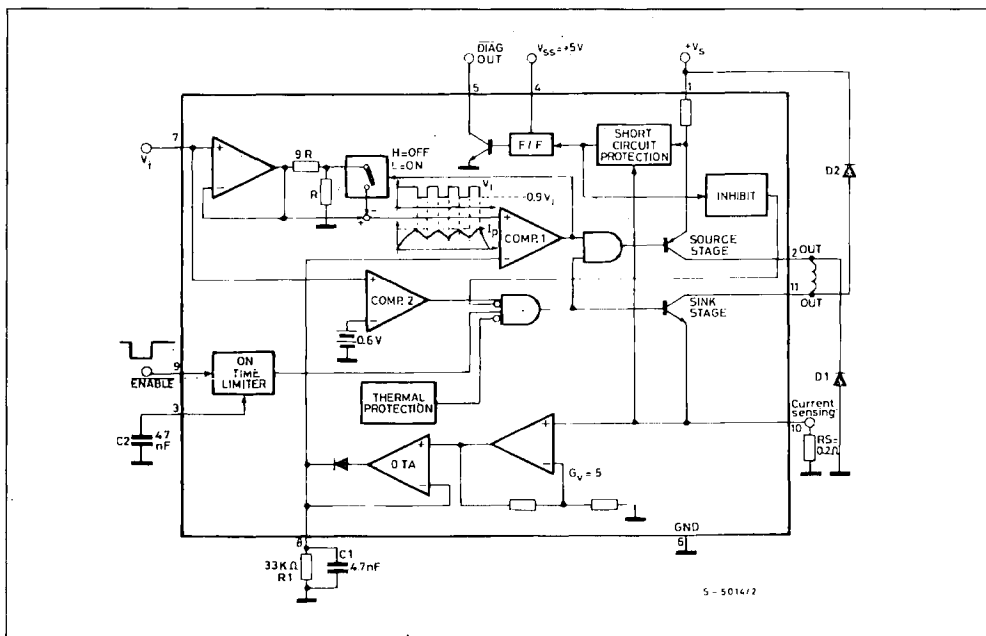

programmed peak value, I_p , and a lower limit of 0.9 I_p .

Other features of the L294 include thermal shut-down, output short circuit protection, overdriving protection and a latched diagnostic output. This output indicates fault conditions such as a short circuit solenoid.

CIRCUIT OPERATION

In most applications the L294 is used with a fixed reference voltage (V_i) and the solenoid is controlled by negative-going pulses on the ENABLE input. When the ENABLE input is active (low level), the output stage is enabled and the load current rises as shown in figure 2.

The load current is sensed by an external resistor (R_s) in the emitter of the sink stage. Through the op amp and transconductance amplifier (OTA), the sensed voltage charges an external RC network ($R1C1$) which determines the switching characteristics of the device.

Figure 2 : Output Current Waveforms of the L294. The Output Current in regulated by Switching between a Peak Value, I_p , and a lower Limit of 0.9 I_p .

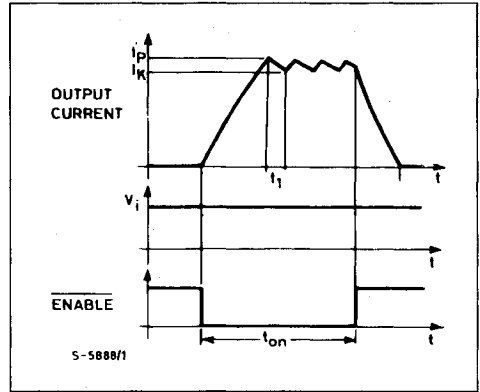
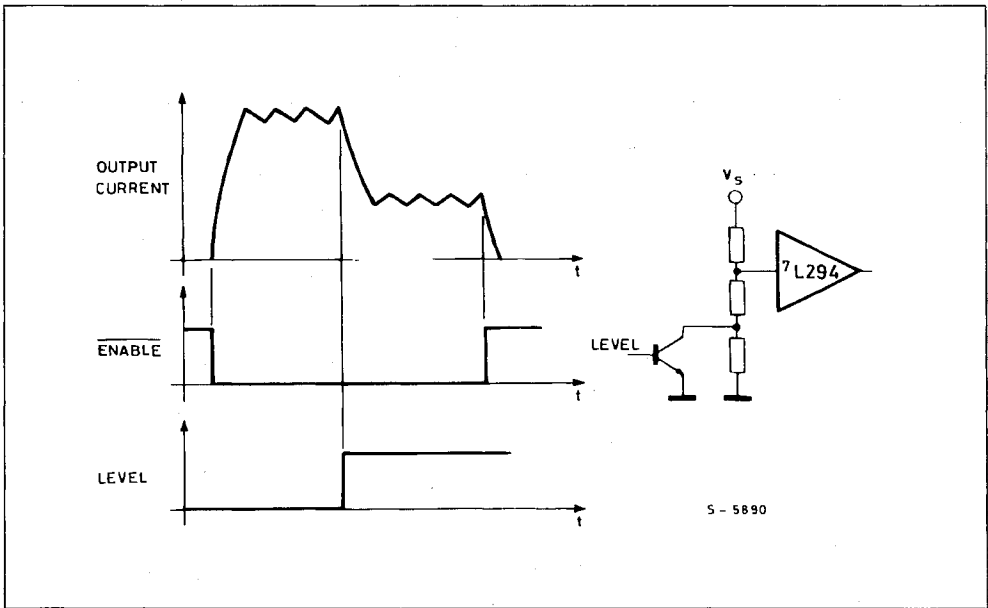

Figure 3 : Two Level Current Control can be implemented by switching V_i between two Values.



The voltage across this RC network is compared with the voltage V_i , which fixes the output peak current. When the current has reached the programmed peak value this comparator switches, turning off the output source stage and closing a switch which reduces the voltage on the non-inverting input to $0.9 V_i$. The load current now recirculates in D1. The voltage on pin 8 falls with a time constant determined by $R1C1$ or the load characteristics, whichever is the longest. In other words, $R1C1$ sets the minimum recirculation time constant.

When the voltage across $R1C1$ has fallen to the $0.9 V_i$ threshold the comparator switches on, turning the output stage back on and restoring the V_i comparison threshold.

The output source stage is switched in this way, regulating the load current, until the ENABLE input goes high again. At this point the output stage is disabled - both source and sink - and the load current recirculates through D1 and D2 to ensure a fast decay. By varying the voltage V_i the peak load current can be programmed to any value in the range 0.6 A to 4 A. This feature can be exploited to implement two-level current control if the fixed reference is replaced by a switched reference as shown in figure 3.

PROTECTION

To protect the load and the L294 from overdriving an on-time limiter inhibits the output stage independently of the ENABLE input if the duration of the input pulse exceeds a period set by the external capacitor $C2$ (figure 4). This circuit is reset by taking the ENABLE input high. The on-time limiter can be disabled by grounding pin 3.

Protection against overheating is incorporated in the form of a thermal shutdown circuit which disables the output stage when the junction temperature exceeds 150°C . The circuit restarts when the temperature has fallen about 20°C .

The L294 is also protected against short circuits to ground, to supply and across the load. Triggered when the source stage current exceed 5 A or the sink stage current exceed $1 V/R_s$, the short circuit protection block inhibits the output stage and sets a flip flop which is supplied by a separate supply voltage V_{ss} . This flip flop is connected to the diagnostic output and signals that all is not well - a shorted solenoid, for example. The diagnostic flip flop is reset by removing the supply V_{ss} .

A LED can be connected to the diagnostic output as shown in figure 5. If the diagnostic function is not re-

quired the V_{ss} supply can be omitted. The short circuit protection, however, still functions, even without V_{ss} .

Figure 4 : On-time Limiter Waveforms. After a Period defined by $C2$ the Output is disabled regardless of the State of ENABLE, protecting against overdriving.

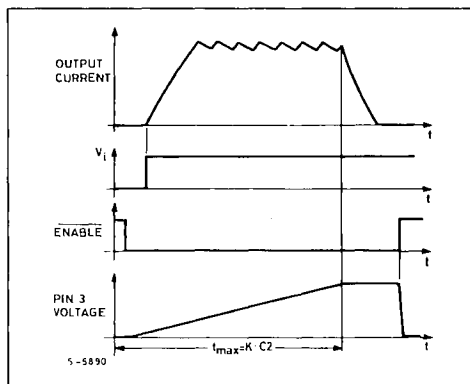

USING THE L294

The basic application circuit for the L294 is shown in figure 5 ; a suggested layout is given in figure 6. The circuit is complete except for the source of V_i . In most cases this will be provided by a simple resistive divider dimensioned to set the desired peak current. With a 0.2Ω sense resistor as shown, the L294 has a transconductance of $1A/V$ for V_i above 600 mV. The device will not work with V_i less than 450 mV and operation is not guaranteed for V_i between 450 mV and 600 mV.

The on-time limiter delay - set by $C2$ - is approximately $120\,000 \times C2$. Pin 3 must be grounded if the on-time limiter isn't used.

Switching frequency depends partly on the timing network $R1C1$ and partly on the load characteristics.

$R1C1$ determines the minimum value of t_1 (see figure 2), which is given by $t_1 \geq 0.1 \times R1C1$. $C1$ must be in the range $2.7 - 10 \text{ nF}$ to ensure stability of the amplifier OTA. $R1$ must be at least $10 \text{ k}\Omega$ to give sufficient gain for OTA. The standard application circuit of figure 5 has a switching frequency of about 10 kHz.

The recirculation diodes should be fast types and rated at 3A (D1) and 1A (D2). If the full 4A capability of the L294 is not used these can be reduced.

Figure 5 : Standard Solenoid driving Application of the L294. Pin 7 must be connected to a Suitable Reference Voltage to set the Peak Current.

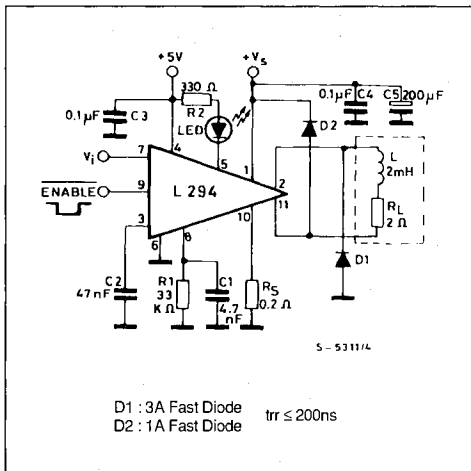

A high initial peak and low holding current can be obtained with the circuit shown in figure 7a. This example supplies a current peak for about 10 ms.

The peak current, I_{OEX} , (see figure 7a) is found from :

$$I_{OEX} = \frac{V_z}{5} \cdot \frac{R2}{R_s} \cdot \frac{1}{R1 + R2}$$

V_z is the zener voltage. The zener and $R5$ can be omitted if a regulated 5V supply is available for point A.

The holding current, I_{hold} , is found from :

$$I_{hold} = \frac{V_z}{5} \cdot \frac{(R2 // R4)}{R_s} \cdot \frac{1}{R1 + (R2 // R4)}$$

The duration of the peak is determined by $R3C1$ and is increased by raising $R3$ or $C1$.

Typical component values are listed in the table below :

	$I_{OEX} = 4 \text{ A}$ $I_{HOLD} = 1 \text{ A}$	$I_{OEX} = 2.5 \text{ A}$ $I_{HOLD} = 0.5 \text{ A}$
R1	10 kΩ	10 kΩ
R2	47 kΩ	27 kΩ
R3	150 kΩ	150 kΩ
R4	2.7 kΩ	1.5 kΩ
R5	0.2 Ω (1 W)	0.27 Ω (0.5 W)
D1	3 A	1.5 A
D2	0.5 A	0.5 A
C1	0.2 μF	0.2 μF

Figure 6 : Suggested printed Circuit Board layout for the Application Circuit of figure 5.

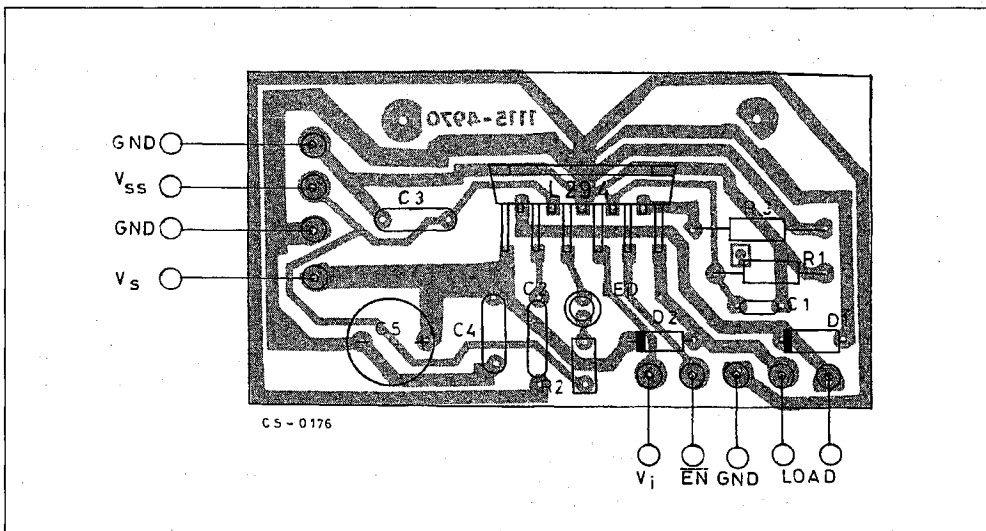

Figure 7a : Application Circuit for two Level Current Control. This Circuit generates a high Peak Current for a Period determined by R3C1 then a lower holding Current.

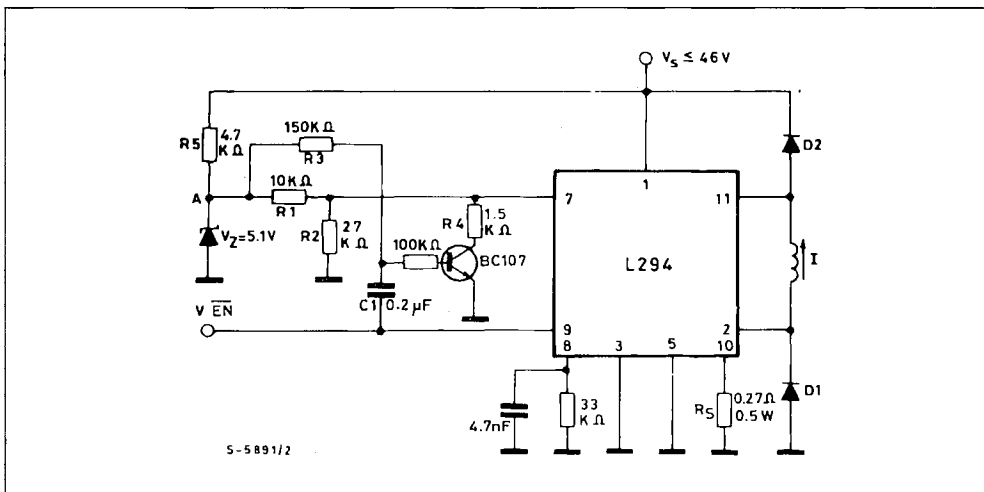

Figure 7b : Output Current Waveform obtained with the Circuit of fig. 7a.

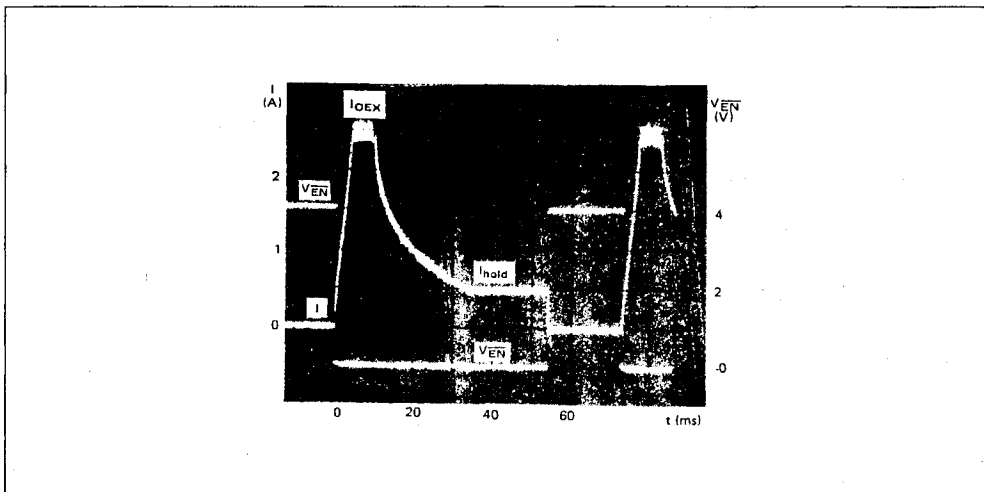

Figure 8 : Pin Functions of the L294.

N°	Function
1	Solenoid Supply Voltage V_S (12-46 V)
2	Output, Source Stage
3	On-time Limiter Time Constant. A capacitor to ground sets delay period ($120\,000 \times C2$ seconds). On-time limiter is disabled by grounding this pin.
4	Supply Input (5 V) for Diagnostic Flip Flop.
5	Diagnostic Output, Open Collector. Signals intervention of latched short circuit protection. Reset by removing pin 1 supply.
6	Ground.
7	V_i Reference Input. Peak output current is proportional to V_i . Transconductance is 1 A/V for $R_S = 0.2 \Omega$ and $V_i \geq 600$ mV.
8	Timing. A parallel RC network from this pin to ground sets the minimum recirculation time constant. The capacitor must be 2.7-10 nF to ensure stability. The resistor must be greater than 10 k Ω .
9	ENABLE. TTL-compatible logic input that controls the solenoid current. The solenoid is driven when this input is at a low level. The on-time limiter overrides enable.
10	Connection for Load Current Sense Resistor.
11	Output, Sink Stage

THE L295 DUAL SWITCHMODE DRIVER

The L295 is a dual switchmode solenoid driver which handles up to 2.5 A per channel at voltages up to 46 V - a total effective power handling of 220 W. Compared to the L294 it offers a more economical solution when 2.5 A is sufficient because there are two drivers per chip. Like the L294 it features switchmode regulation of the output current and thermal shutdown. Additionally it has a separate logic supply input so that the logic can be run at a lower voltage, reducing dissipation.

Intended for inductive load driving, the L295 is particularly suitable for solenoids and stepper motors. One L295 drives two solenoids and two L295s can drive the four phases at a unipolar stepper motor or the two phases of a bipolar stepper motor in bridge configuration.

Each channel of the L295 is controlled by a TTL-level digital input and the peak load current is programmed, independently for each channel, by a voltage reference input. A chip enable input is also provided to disable both channels together.

INSIDE THE L295

Internally the L295 (figure 9) bears little resemblance to the L294. Looking at channel one, when the V_{IN1} input goes high the output transistors Q1 and Q2 are switched on (the enable input EN is assumed to be active, i.e. low). The current in the load then rises exponentially, as shown in figure 10, until

the voltage across the external sense resistor R_{S1} reaches the current program reference voltage V_{ref1} .

The comparator COMP1 switches and sets the flip flop FF1 which turns off the source transistor Q1. The load current now recirculates through D2-Q2- R_{S1} and decays.

What happens next is determined by the oscillator components R and C on pin 9. If these components are present the flip flop is reset by the next clock pulse before the current decays very far. The output stage is therefore turned on again and the load current rises.

When it reaches the peak value COMP1 switches again, setting the flip flop and disabling the output stage. This process is repeated, regulating the load current until V_{IN1} goes low. The output stage is then disabled and the current falls off rapidly, recirculating through D1 and D2 (figure 10).

If the oscillator components are omitted and pin 9 grounded the current simply decays slowly until V_{IN1} goes low. The output stage is then disabled and the load current recirculates through D1 and D2. This case is illustrated by the waveforms of figure 11. Note that in this case the peak current level is controlled.

Unlike the L294, the switching frequency of the current regulation loop is determined by the oscillator components R and C (the L294 is also affected by the load). Typically, the switching frequency will be

10-30 kHz. Another difference between the two devices is that the L294 gives a constant ripple, the L295 does not.

TWO LEVEL CONTROL

Since the peak load current is programmed by the reference voltage (for each channel), two level cur-

rent control can be obtained by switching between two reference voltages. A high V_{ref} is selected initially to give a high initial current peak. Then, after a suitable interval, V_{ref} is reduced to give the lower holding current (figure 12). Two level current control is very useful for solenoids which require a high initial current peak for fast actuation.

Figure 9 : Internal Block Diagram of the L295 Dual Switchmode Driver.

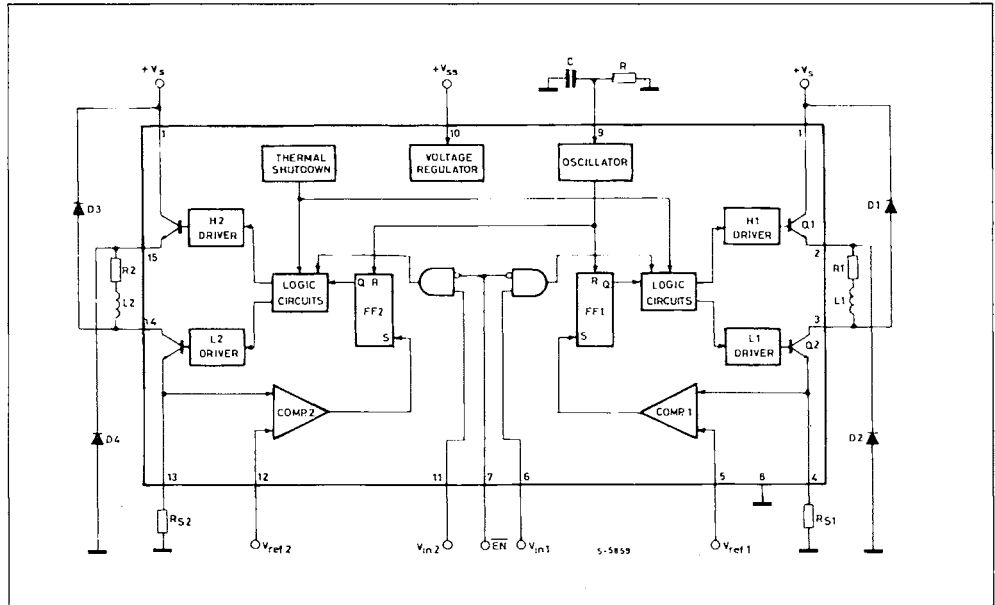

Figure 10 : Waveforms illustrating Normal Operation of the L295.

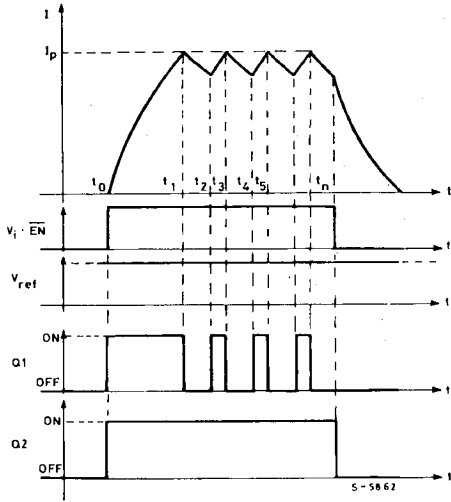

Figure 11 : When the Oscillator Components are omitted and Pin 9 grounded the L295 delivers a simple Current Peak to the Load.

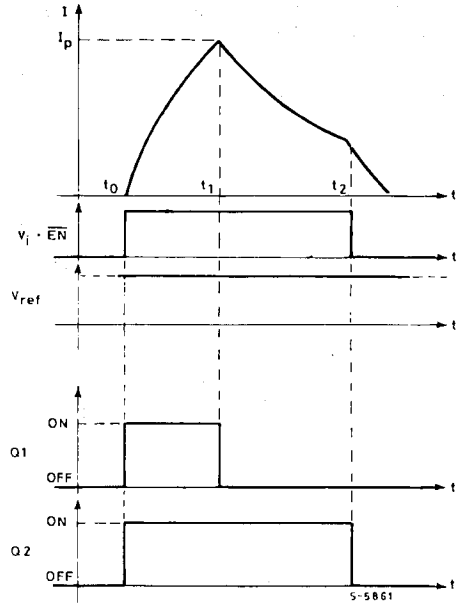
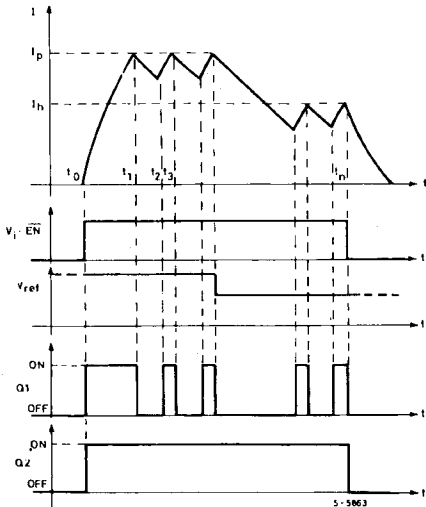

Figure 12 : Two Level Current Control is obtained by switching V_{ref} between two Values.



L295 APPLICATION HINTS

The basic application circuit of the L295 is shown in figure 14. A suitable layout is given in figure 15.

Suitable values for the oscillator components, R and C, can be found from the nomogram, figure 16. The value for the reference voltages depends on the desired peak current and is equal to $I_p R_s$; it must be in the range 0.2 V to 2 V.

If the V_{ref} inputs are left open circuit the L295 assumes an internal default value of 2.5 V giving a peak current of $2.5/R_s$ amperes.

The L295 can also be used to drive unipolar stepper motors. For a four phase motor two devices are used, connected as shown in figure 17. This circuit

provides switchmode regulation of the load current with a chopper rate of about 25 kHz. The enable inputs (EN, connected together) enable/disable the whole circuit and the channel inputs $V_{in1} \dots V_{in4}$ are driven by a suitable translator circuit. Phases 1 and 2 must not be energised together because they share the same sense resistor. The same applies to channels 3 and 4. However, 'two phase on' drive is still possible for bifilar motors where phases one and two represent one winding and 3 & 4 the other, and also for variable reluctance motors with phase 1 adjacent to phase 3 etc.

Two L295s could also be used to drive a bipolar stepper motor in systems where a translator already exists.

Figure 13 : Pin Functions of the L295.

N°	Function
1	Solenoid Supply Voltage, V_s (12-46 V).
2	Channel one Output, Source Stage.
3	Channel one Output, Sink Stage.
4	R_{S1} . Sense Resistor Connection, Channel one.
5	V_{ref1} . A voltage on this pin sets peak current of channel one. If this pin is left open or connected to V_{SS} a default V_{ref} of 2.5 V is assumed. An externally applied V_{ref} must be in the range 0.2 to 2 V.
6	V_{in1} . Logic Input for Channel one. Driver is active when V_{in1} is high and \overline{EN} low.
7	\overline{EN} . Chip Enable (active low). When high both channels are disabled.
8	Ground.
9	Oscillator Timing Network. This pin is grounded to produce a single peak.
10	V_{SS} . Logic supply voltage, internally regulated. (4.75-10 V).
11	V_{in2} . Logic Input for Channel two. Driver is active when V_{in2} is high and EN low.
12	V_{ref2} . Voltage input, controls peak current of channel two. If left open or connected V_s an internal 2.5 V reference is assumed. An externally applied V_{ref} must be in the range 0.2 to 2 V.
13	R_{S2} . Sense Resistor Connection, Channel two.
14	Channel two Output, Sink Stage.
15	Channel two Output, Source Stage.

Figure 14 : Typical application Circuit of the L295. R1 L1 and R2 L2 are solenoids.

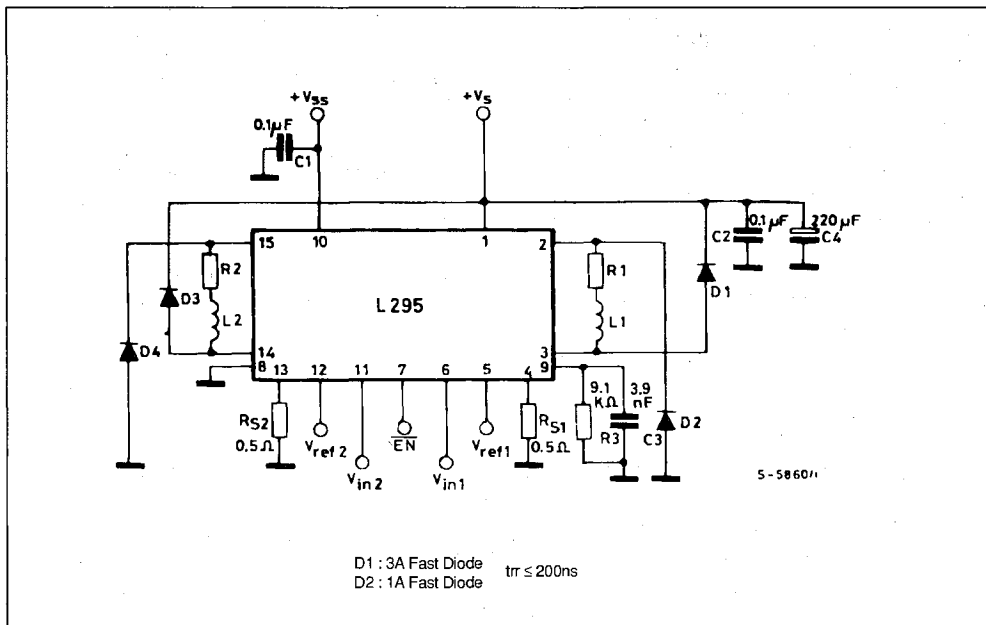

Figure 15 : Suggested printed Circuit Board layout for the Circuit of figure 14.

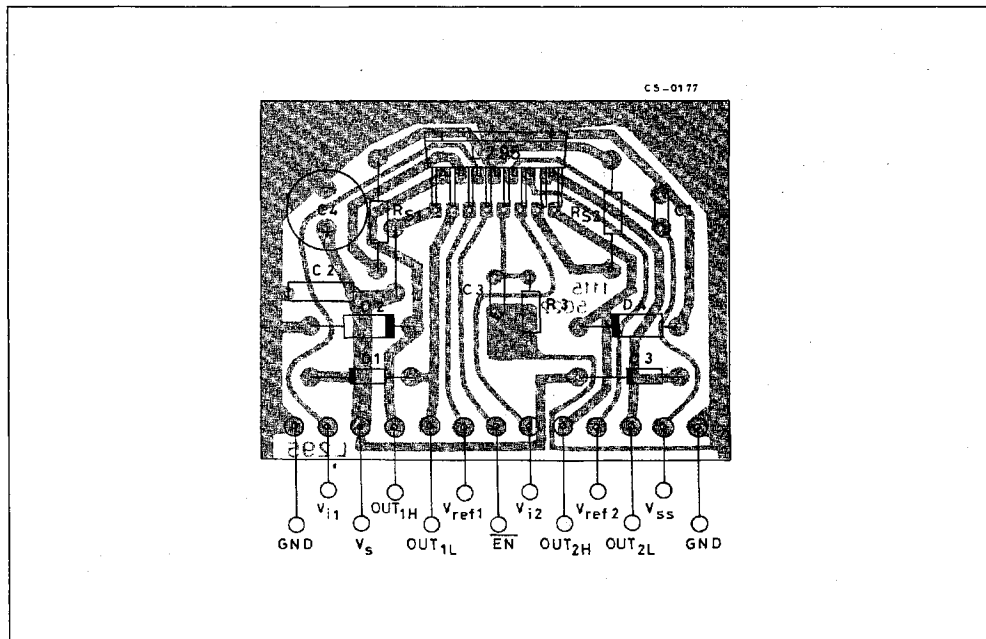

Figure 16 : Nomogram for the Selection of Values for the Oscillator components. RC.

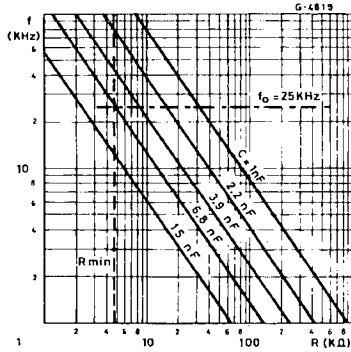

Figure 17 : Two L295s, connected as shown, can be used to drive a four Phase Unipolar Stepper Motor.

