

Simple reverse-polarity-protection circuit has no voltage drop

Aruna Prabath Rubasinghe, University of Moratuwa, Moratuwa, Sri Lanka

 Common methods of reverse-voltage protection employ diodes to prevent damage to a circuit. In one approach, a series diode allows current to flow only if the correct polarity is applied (Figure 1). You can also use a diode bridge to rectify the input so that your circuit always receives the correct polar-

ity (Figure 2). The drawback of these approaches is that they waste power in the voltage drop across the diodes. With an input current of 1A, the circuit in Figure 1 wastes 0.7W, and the circuit in Figure 2 wastes 1.4W. This Design Idea suggests a simple method that has no

voltage drop or wasted power (Figure 3).

Select a relay to operate with the reverse-polarity voltage. For example, use a 12V relay for a 12V supply system. When you apply correct polarity to the circuit, D_1 becomes reverse-biased, and the S_1 relay remains off. Then connect the input- and output-power lines to the normally connected pins of the relay, so current flows to the end circuit. Diode D_1 blocks power to the relay, and the protection circuit dissipates no power.

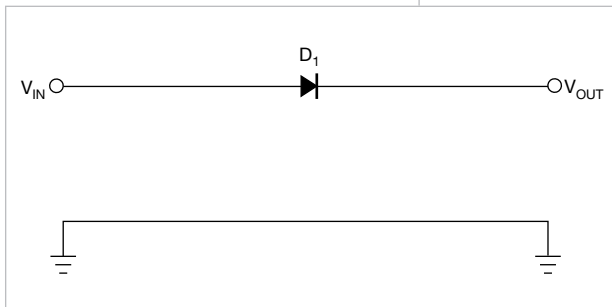

Figure 1 A series diode protects systems from reverse polarity but wastes power in diode losses.

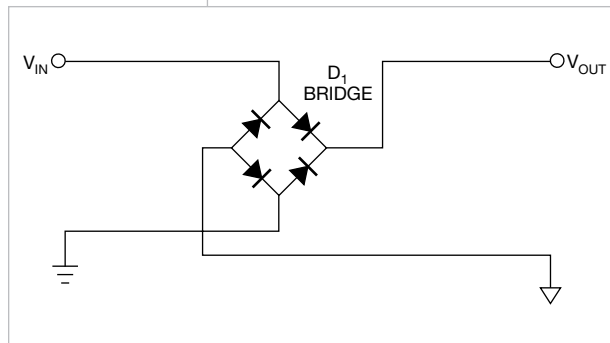

Figure 2 You can use a bridge rectifier so that your system works no matter what the input polarity is. This circuit wastes twice the power, in diode losses, of the circuit in Figure 1.

When you apply incorrect reversed polarity, diode D_1 becomes forward-biased, turning on the relay (Figure 4). Turning on the relay cuts the power to the end circuit, and red LED

D_3 turns on, indicating a reverse voltage. The circuit consumes power only if reverse polarity is applied. Unlike FETs or semiconductor switches, relay contact switches have low on-resistance,

meaning that they cause no voltage drop between the input supply and the circuit requiring protection. Thus, the design is suitable for systems with tight voltage margins. **EDN**

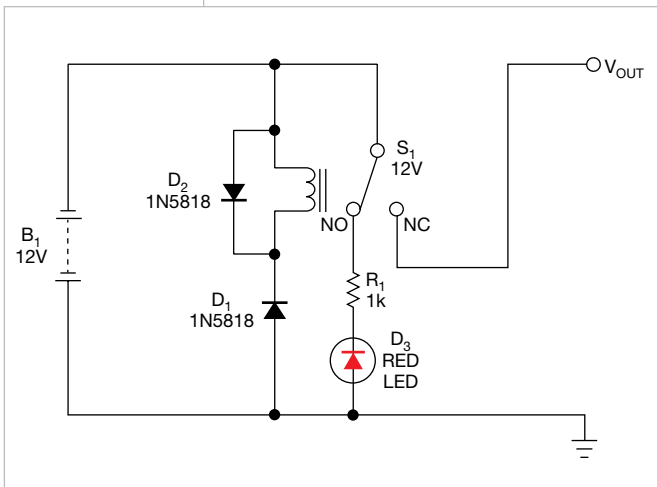
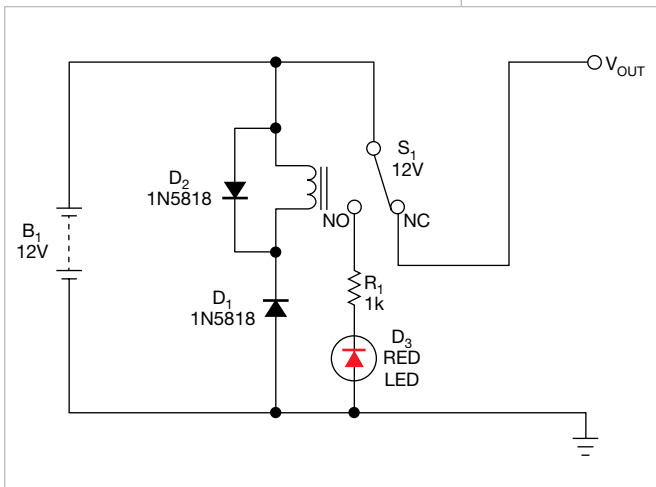

Figure 3 You can wire a relay switch to pass power to your system with no power loss. D_2 clamps inductive kicks from the relay coil.

Figure 4 With reversed input voltage, the relay switch engages, interrupting power to the system, and the LED lights.