

**ASSEMBLING
AND USING
YOUR**

Heathkit

**BATTERY
ELIMINATOR
MODEL BE-4**

595-59

HEATH COMPANY

BENTON HARBOR,
MICHIGAN

STANDARD COLOR CODE — RESISTORS AND CAPACITORS

| AXIAL LEAD RESISTOR | INSULATED UNINSULATED Color | FIRST RING BODY COLOR First Figure | SECOND RING END COLOR Second Figure | THIRD RING DOT COLOR Multiplier | DISC CERAMIC RMA CODE |
|--|---|--|--|---|-----------------------|
| | BLACK BROWN RED ORANGE YELLOW GREEN BLUE VIOLET GRAY WHITE | 0 1 2 3 4 5 6 7 8 9 | 0 1 2 3 4 5 6 7 8 9 | None 0 00 ,000 0,000 00,000 000,000 0,000,000 00,000,000 000,000,000 | |
| RADIAL LEAD DOT RESISTOR | 5-DOT RADIAL LEAD CERAMIC CAPACITOR | | | EXTENDED RANGE TC CERAMIC HICAP | |
| RADIAL LEAD (BAND) RESISTOR | BY-PASS COUPLING CERAMIC CAPACITOR | | | AXIAL LEAD CERAMIC CAPACITOR | |

The standard color code provides all necessary information required to properly identify color coded resistors and capacitors. Refer to the color code for numerical values and the zeroes or multipliers assigned to the colors used. A fourth color band on resistors determines tolerance rating as follows: Gold = 5%, silver = 10%. Absence of the fourth band indicates a 20% tolerance rating.

The physical size of carbon resistors is determined by their wattage rating. Carbon resistors most commonly used in Heathkits are 1/2 watt. Higher wattage rated resistors when specified are progressively larger in physical size. Small wire wound resistors 1/2 watt, 1 or 2 watt may be color coded but the 1 band will be double width.

MOLDED MICA TYPE CAPACITORS

| | | |
|--------------------------------------|--|---|
| CURRENT STANDARD CODE | RMA 3-DOT (OBSOLETE) RATED 500 W.V.D.C. ± 20% TOL. | BUTTON SILVER MICA CAPACITOR |
| RMA (5-DOT OBSOLETE CODE) | RMA 6-DOT (OBSOLETE) | RMA 4-DOT (OBSOLETE) |

MOLDED PAPER TYPE CAPACITORS

| | | |
|--|---|--------------------------------|
| TUBULAR CAPACITOR <p>Normally stamped for value</p> <p>A 2 digit voltage rating indicates more than 900 V. Add 2 zeros to end of 2 digit number.</p> | MOLDED FLAT CAPACITOR Commercial Code | JAN. CODE CAPACITOR |
|--|---|--------------------------------|

The tolerance rating of capacitors is determined by the color code. For example: red = 2%, green = 5%, etc. The voltage rating of capacitors is obtained by multiplying the color value by 100. For example: orange = 3 × 100 or 300 volts. Blue = 6 × 100 or 600 volts.

In the design of Heathkits, the temperature coefficient of ceramic or mica capacitors is not generally a critical factor and therefore Heathkit manuals avoid reference to temperature coefficient specifications.

ASSEMBLY AND OPERATION OF THE HEATHKIT BATTERY ELIMINATOR

MODEL BE-4

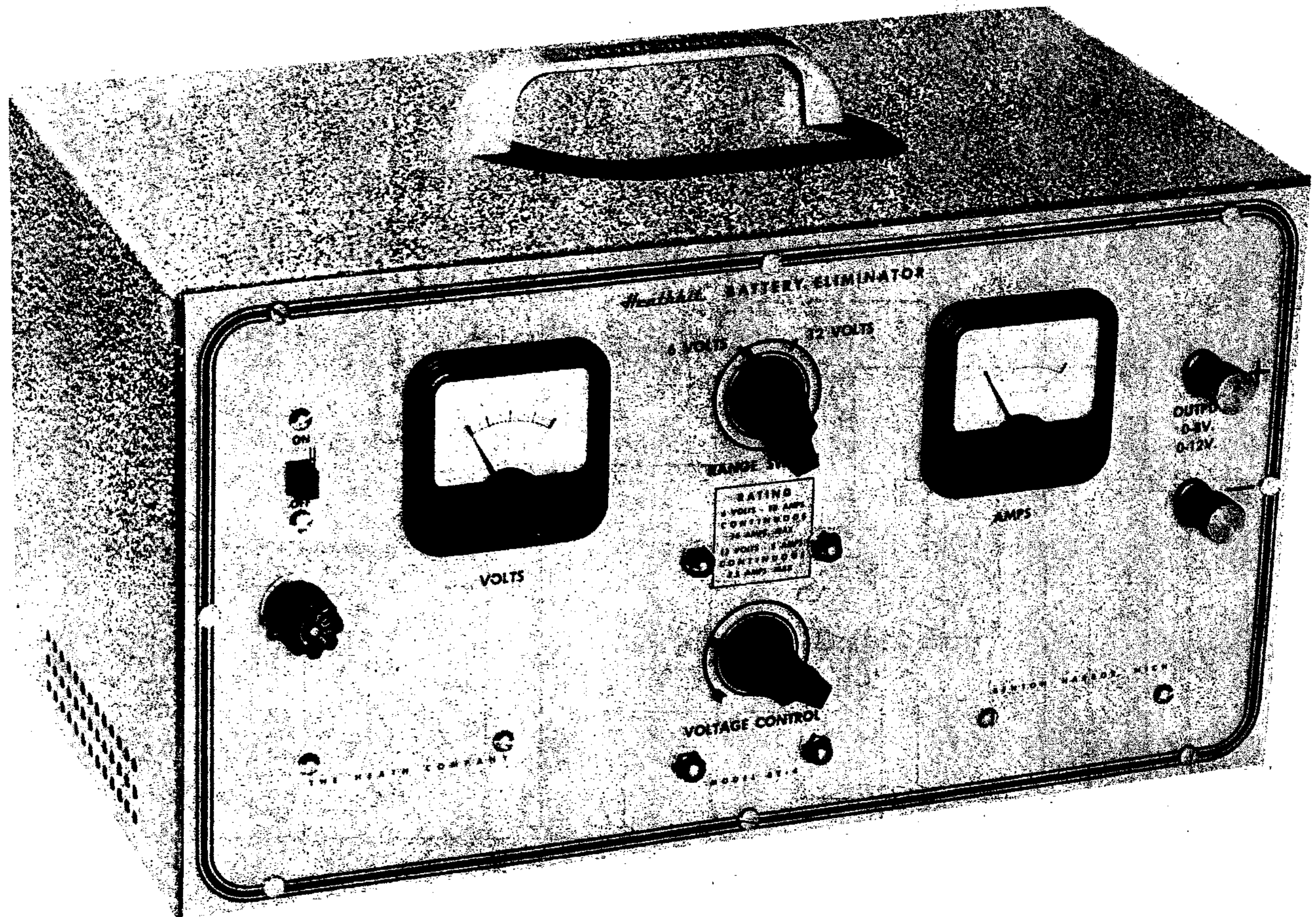

SPECIFICATIONS

Continuously variable voltage output

0-8 volts DC.....10 amperes continuously
15 amperes maximum intermittent

0-16 volts DC.....5 amperes continuously
7.5 amperes maximum intermittent

Power Requirements..... 105-125 V., 50-60 cycles AC at 175 watts

Dimensions..... 13 1/4" wide x 7 1/2" deep x 7 1/4" high

Approximate shipping weight..... 22 lbs.

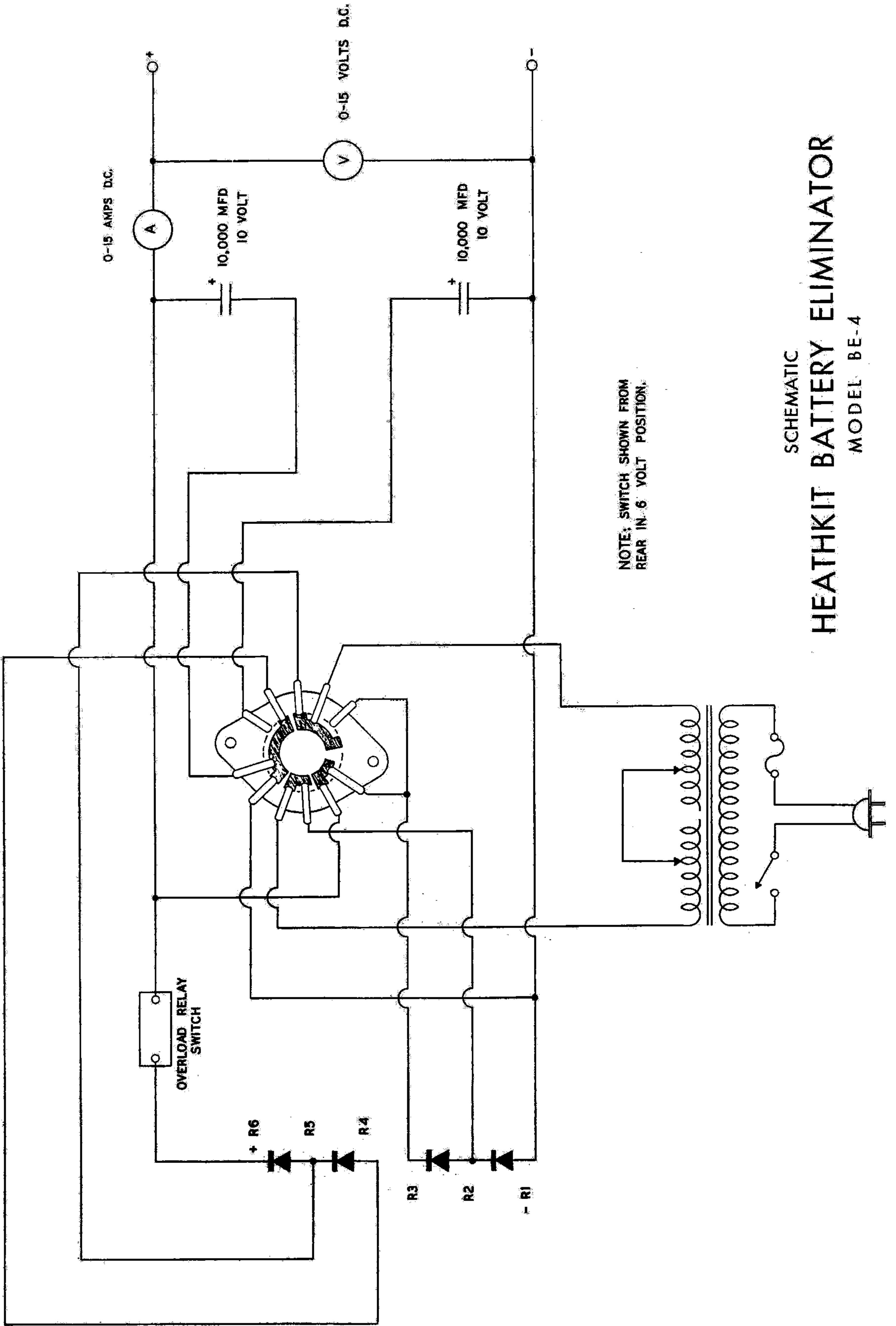

NOTE: SWITCH SHOWN FROM REAR IN '6' VOLT POSITION.

SCHEMATIC
HEATHKIT BATTERY ELIMINATOR
 MODEL BE-4

NOTES ON ASSEMBLY AND WIRING

The Heathkit Battery Eliminator is designed to supply a clean, well filtered variable DC voltage. While its primary function is to operate car radios under repair, the unit can also be used to charge storage batteries, should the occasion arise. Through a panel switching system the BE-4 will deliver 6 volts at 10 amperes as a full wave rectifier, or 12 volts at 5 amperes as a voltage doubler. This outstanding feature vastly increases the versatility of the battery eliminator through the availability of a 12 volt supply for car radios designed to operate from a 12 volt storage battery.

PRELIMINARY NOTES AND INSTRUCTIONS

Unpack the kit carefully and check each part against the parts list. In so doing, you will become acquainted with the parts. If a shortage is found, please notify us promptly and attach the inspection slip to your claim. Screws, nuts and washers are counted mechanically, and if a few are missing please secure them locally. Use the charts on the inside covers of this manual to identify the parts.

Read the manual completely through before starting actual construction. In this way you will become acquainted with the general procedure used. Study the pictorials and diagrams to become familiar with the circuit layout and location of parts. When actually assembling and wiring, read the whole article through, so that no suggestions in the article will be missed.

Read the note on soldering on the inside back cover of the construction manual. Make a good mechanical joint of each connection with clean metal to clean metal. Use only good quality rosin core radio type solder. Paste or acids are difficult to remove and minute amounts left combined with moisture from the air form a corrosive product. Weeks or months later, corrosion may result in untimely failure.

NOTE: ALL GUARANTEES ARE VOIDED AND WE WILL NOT REPAIR OR SERVICE INSTRUMENTS IN WHICH ACID CORE SOLDER OR PASTE FLUXES HAVE BEEN USED. WHEN IN DOUBT ABOUT SOLDER, IT IS RECOMMENDED THAT A NEW ROLL PLAINLY MARKED "ROsin CORE RADIO SOLDER" BE PURCHASED.

To facilitate describing the location of parts, the various mounting locations have been labeled with an A, B, C, etc. Actually labeling these positions on the chassis with a pencil will aid in the step-by-step construction. Also certain switch contact lugs, rectifier plate connections, etc. have been called out so that wiring descriptions are more clearly indicated. The pictorials show this numbering.

The layout is straightforward and construction should cause no difficulty providing the step-by-step procedure is observed. Care should be exercised in mounting of parts so as not to damage them. When installing the heavy solid bare wire, use insulated sleeving to eliminate the possibility of a short circuit through the accidental touching of bare wire.

STEP-BY-STEP ASSEMBLY

It is suggested that the following step-by-step assembly instructions be used and each step checked off as it is completed. ()

MOUNTING OF PARTS

RECTIFIER

Carefully inspect the rectifier assembly, noting that it is essentially divided into two 9 plate sections, each section having three solder terminals. Note that in each group of three terminals, one of the terminals is stamped with a positive (+) mark. It is of extreme importance that these positive terminals be identified before the rectifier is mounted.

CAUTION: NEVER LOOSEN THE NUTS HOLDING THE RECTIFIER PLATES IN PLACE, AS THE RECTIFIER MAY BE SERIOUSLY DAMAGED IF IT IS TAMPERED WITH IN ANY WAY.

- () Observing Figure 2, mount the overload switch on R6 as shown. This requires a 10 x 3/8 spacer, lockwasher and a nut. Make certain that the long terminal of the switch is the one which connect to R6.

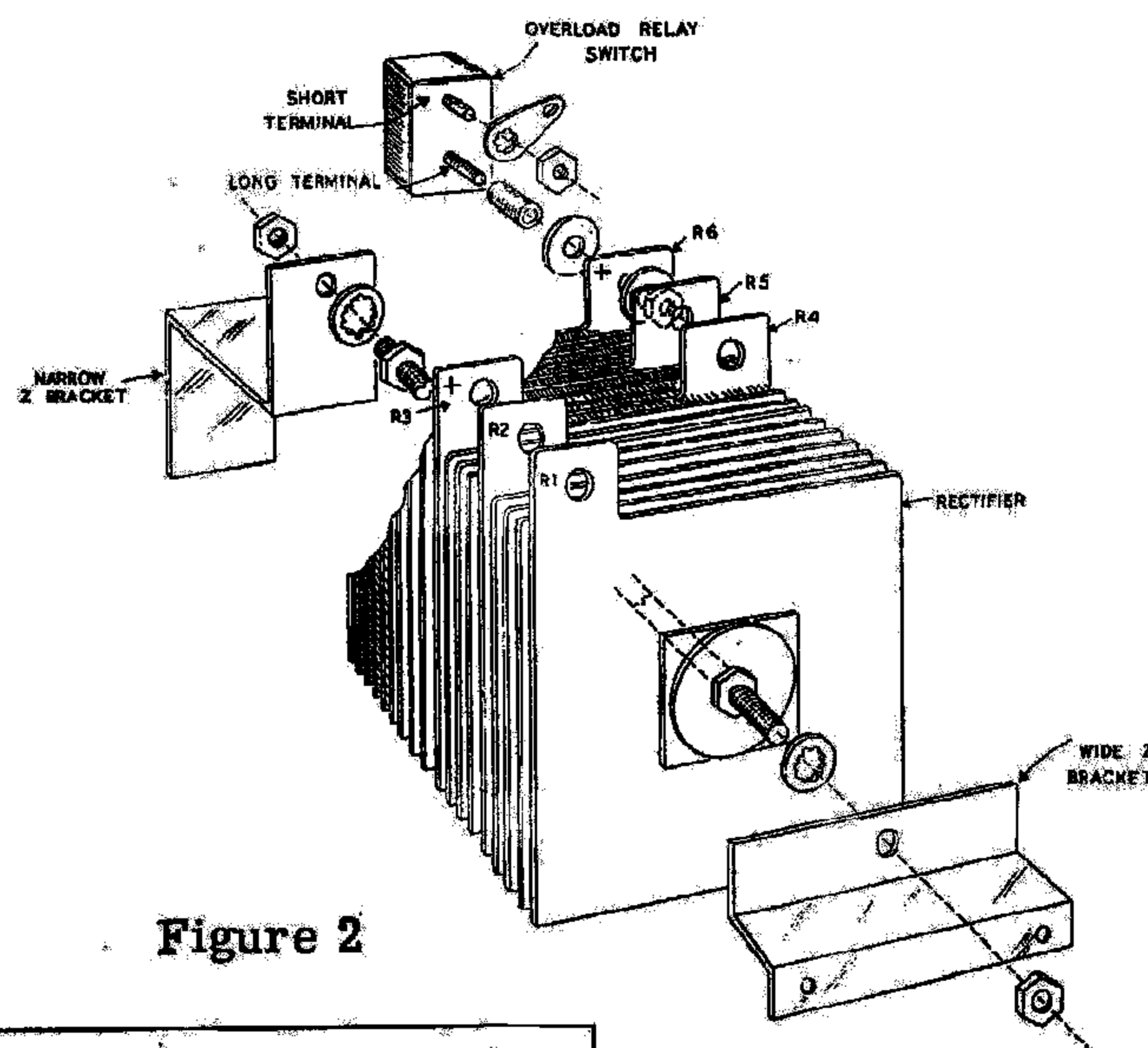
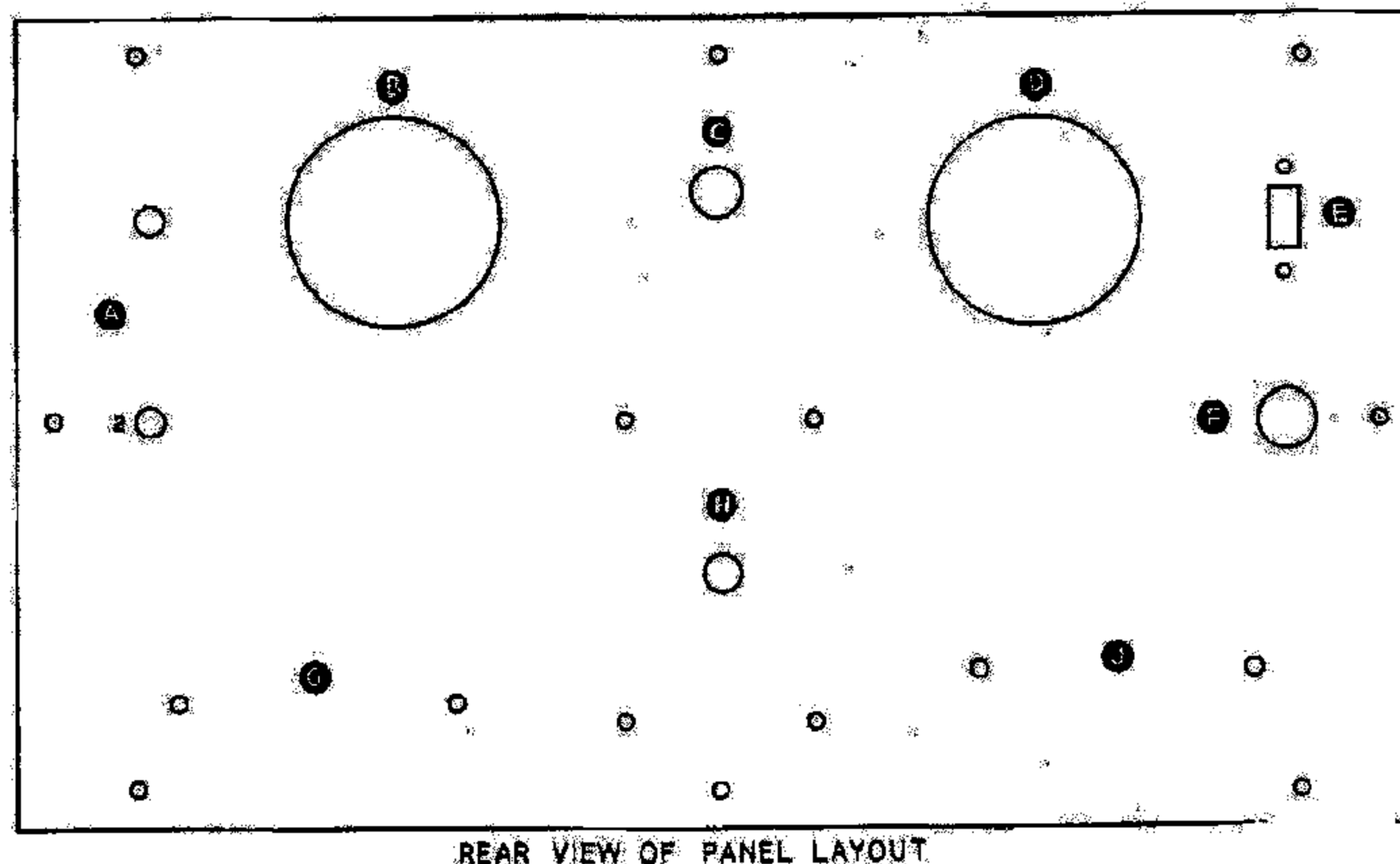

Figure 2

Figure 1



- () Place a #10 solder lug and a nut on the short terminal of the overload switch.
- () Mount the narrow Z bracket on the rectifier stud using a lockwasher and a nut. This Z bracket is mounted at the same end of the rectifier assembly where the automatic overload relay switch was previously mounted.
- () Mount the wide Z bracket on the other end of the rectifier stud using a lockwasher and nut.
- () Mount the rectifier on the panel in location J, using two 6-32 screws, lockwashers, and nuts.

MOUNTING OF SUB-CHASSIS

- () Mount the two condenser mounting clamps on the sub-chassis as shown in Pictorial 1. Be sure that the placement of the condenser clamps corresponds with the pictorial.
- () Mount the condenser sub-chassis on the panel at location G, using two 6-32 screws, lockwashers and nuts. The panel will now stand upright and the remaining parts can be conveniently mounted.

TRANSFORMER AND WINDING CONTACTOR (See Figure 3.)

- () Slide the shaft of the winding contactor through the bushing and crimp the C washer down on the slotted section of the shaft.
- () Place a lockwasher over the bushing and slide the bushing through panel hole H. Slip on a control nickel washer and fasten the bushing to the panel with a control nut. Bend contact springs if necessary so that actual contact will be made with transformer winding.

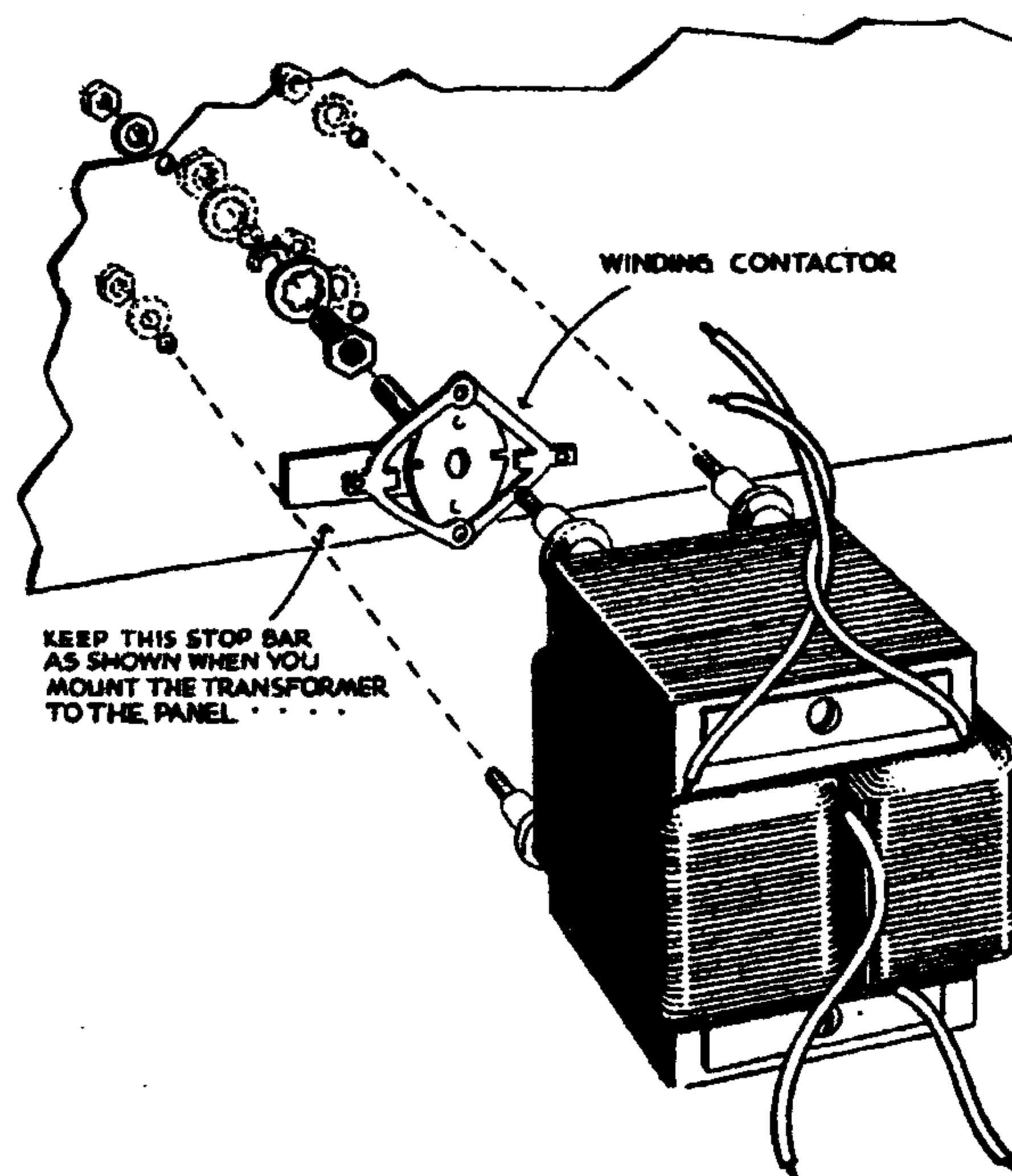

Figure 3

- () Note that the power transformer has two yellow leads and two black leads. Hold the stop bar of the winding contactor in a horizontal position as shown in Figure 3 and place the four mounting studs of the power transformer (black leads on top) in the four panel openings provided. Fasten the transformer to the panel using nickel washers and hex cap nuts.

CONDENSER MOUNTING CLAMP AND 10,000 μ fd CONDENSERS

- () Mount both of the 10,000 μ fd condensers in the mounting clamps on the sub-chassis with the solder lugs all in line and the red or positive terminal toward the panel. (See Pictorial 1.)
- () Slide the clamp screws through the holes provided in each clamp and use a lockwasher and nut on each screw. Tighten screws firmly without damaging the condenser molded case.

FUSE HOLDER

- () Mount the fuse holder in location F. Use the lockwasher, rubber washer and nut. Orient the solder lugs as shown in Pictorial 1.

OFF-ON SWITCH

- () Mount the off-on switch in location E using two 6-32 screws, lockwashers and nuts. Mount the switch with the lugs in the same relative position as shown in Figure 4, otherwise the switch action will be inverted.

OUTPUT TERMINALS

- () Mount the output terminals in location A and as shown in Figure 1. Be sure to use flat and shoulder fiber washers against the panel and the #8 solder lugs and nuts in the exact order shown. Bend the solder lugs outward slightly to prevent possible shorting to the panel.

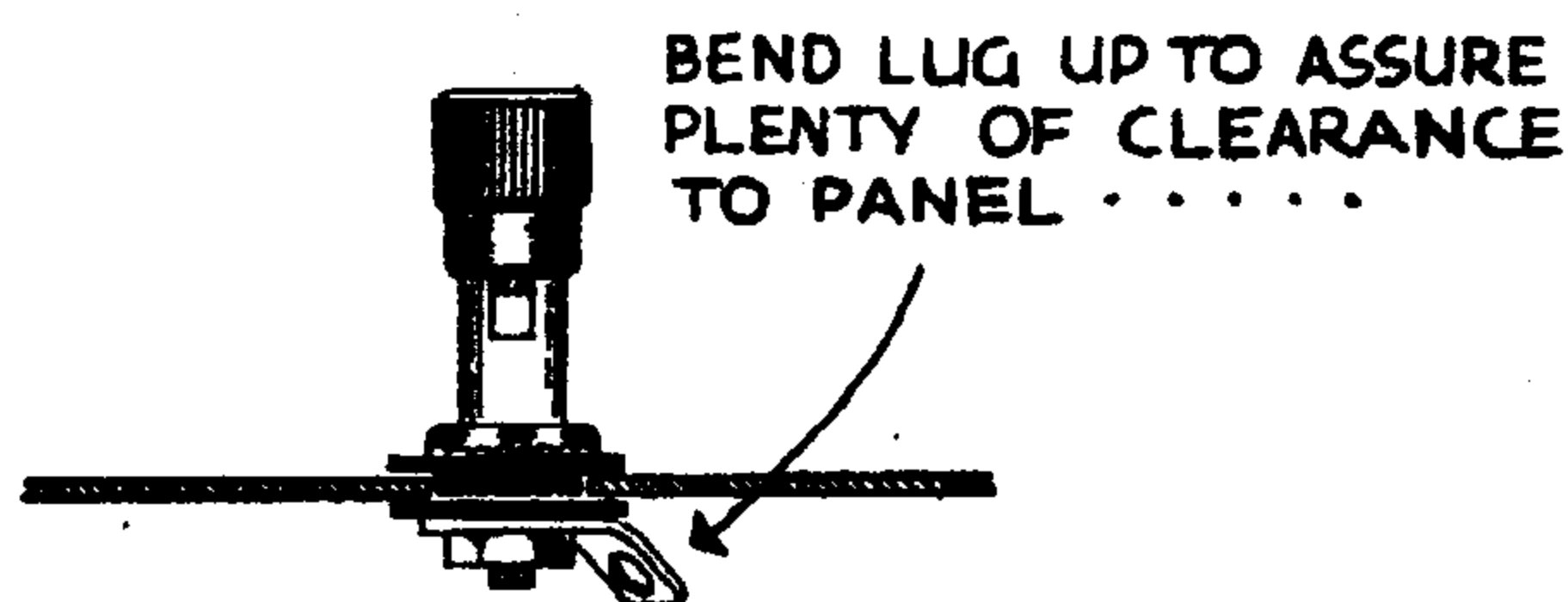

MOUNTING OF OUTPUT TERMINALS

Figure 4

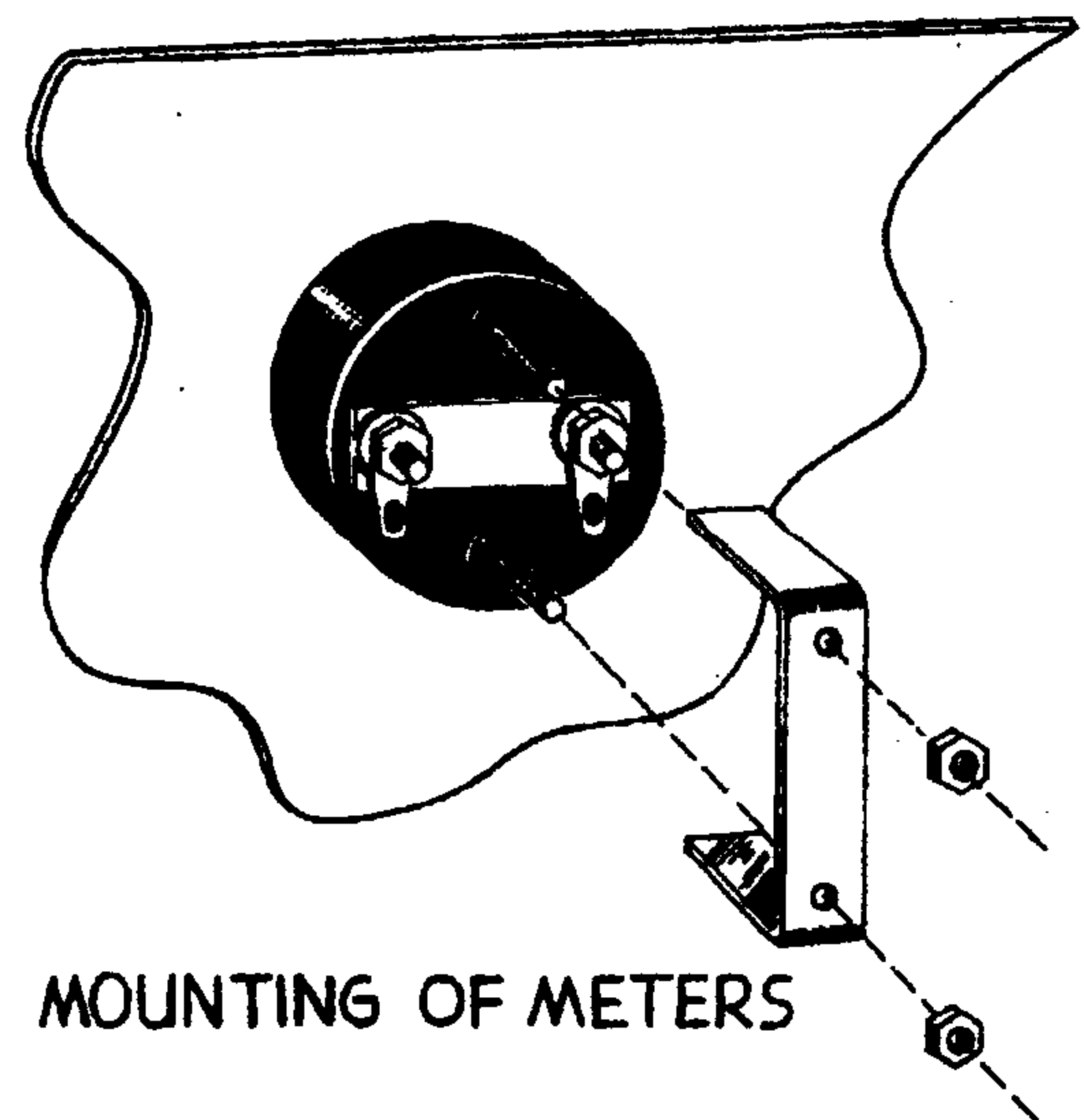

Figure 5

METERS

- () Slide the DC voltmeter through hole D and align it so that the scale reads correctly from the front. Place the meter mounting bracket over the top and bottom screws protruding from the back of the meter case and place a nut on each of the screws and tighten so that the meter is held firmly in place.
- () Mount the DC ammeter using the same method as described above. The DC ammeter should be mounted in location B.
- () Mount the voltage range switch in panel location C using lockwasher, flat nickel washer and control mounting nut.

This concludes the mounting of parts and wiring can now begin.

WIRING

(S) means solder.

(NS) means do not solder yet.

NOTE: ALL GUARANTEES ARE VOIDED AND WE WILL NOT REPAIR OR SERVICE INSTRUMENTS IN WHICH ACID CORE SOLDER OR PASTE FLUXES HAVE BEEN USED. WHEN IN DOUBT ABOUT SOLDER, IT IS RECOMMENDED THAT A NEW ROLL PLAINLY MARKED "ROSIN CORE RADIO SOLDER" BE PURCHASED.

TRANSFORMER

- () Connect the yellow lead which is nearest the rectifier to C4 (S).
- () Connect the other yellow lead to C10 (S).
- () Twist the two black leads together and connect one to E1 (S).
- () Connect the other black lead to F2 (S).

Note: The panel range switch designated as C actually has two sets of switch contacts and solder terminals. These two sets of terminals operate in parallel on all positions so as to effectively increase the power handling capabilities of the switch. When wiring to the switch, pass the bare wire through the first solder terminal and into the corresponding second solder terminal, being sure to solder the wire to both terminals.

DC VOLTMETER

- () Connect a piece of insulated wire to D1 (S) and dress the wire over the switch assembly and ammeter and connect to A2 (NS).
- () Fasten a similar length of insulated wire to D2 (S), twist it around the wire fastened in the step above and connect it to A1 (NS).

PREPARATION OF HEAVY SOLID WIRE

For good workmanship, appearance and easy working, the #16 wire should be straightened and all kinks removed. This can be accomplished by clamping one end of the #16 wire in a vise and grasping the other end securely with a large pair of pliers. The wire should be pulled so as to stretch its entire length. Repeat the process several times with a steady firm pull.

DC AMMETER

- () Slip a 4" length of insulated sleeving over a 4 1/2" length of bare wire and bend the wire to connect between B1 (S) and A1 (S).

Note: When using sleeving, be sure to place it over the wire before the wire is bent.

- () Slip a 4 1/2" length of sleeving over a 5" length of bare wire and connect to B2 (S) and to the red marked or positive condenser terminal L2 (NS).

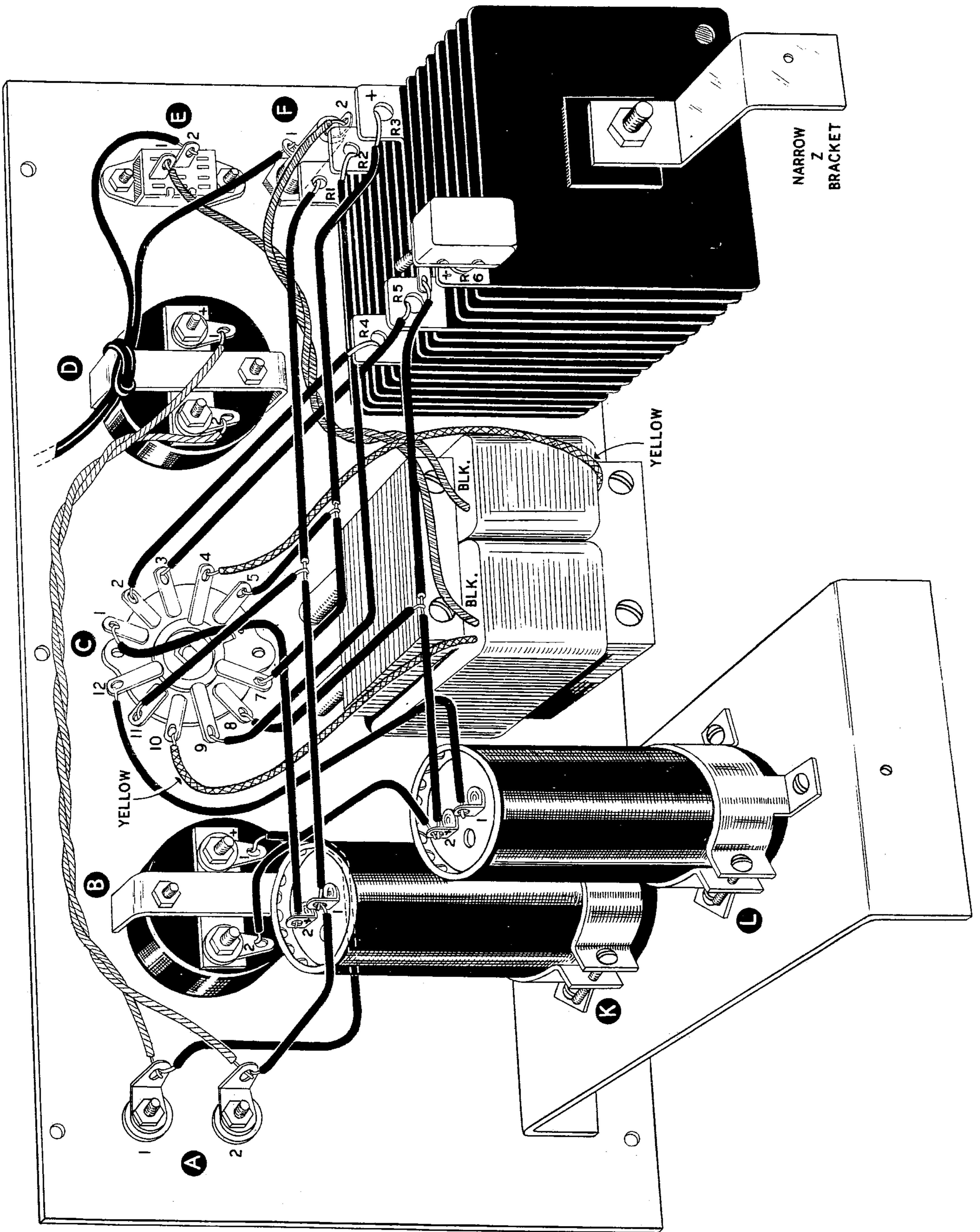

PICTORIAL 1

RECTIFIER

WARNING: In all connections to the rectifier be careful not to drop solder between the plates of the rectifier unit thereby causing a short circuit.

- () Slip a 3" length of insulated sleeving over a 3 1/2" length of bare wire. Connect to R4 (S).
- () Connect the remaining end of the bare wire to C2 (S).
- () Slip a 4" length of insulated sleeving over a 4 1/2" length of bare wire. Connect to R5 (S).
- () Dress the length of bare wire as shown in the pictorial and connect the remaining end to C3 (S).
- () Slip two 3" lengths of sleeving over a 7" length of bare wire. Connect one end of the bare wire to the solder lug on the overload relay switch (S).
- () Connect the other end of the bare wire to the positive condenser terminal L2 (S).
- () Slip a 4" length of sleeving over a 4 1/2" length of bare wire. Loop one end of the bare wire and connect to the piece of bare wire just installed in the previous step by separating the two lengths of sleeving (S). (See pictorial.)
- () Connect the remaining end of the bare wire to C8 (S).
- () Slip a 5" length of sleeving over a 6" length of bare wire and connect to condenser terminal L1 (S).
- () Dress the bare wire as shown in the pictorial, and connect to C12 (S).
- () Slip a 6" length of sleeving over a 7" length of bare wire and connect one end to R2 (S).
- () Connect the remaining end to C9 (S). Dress as shown in Pictorial 1.
- () Slip 3 1/2" and 5 1/2" lengths of sleeving on a 10" length of bare wire and connect one end of the bare wire to R1 (S).
- () Connect the remaining end of the bare wire to condenser terminal K1 (NS).
- () At the junction of the two pieces of sleeving, connect a 2" length of bare wire covered with a short length of sleeving (S) and connect the remaining end of the bare wire to C11 (S).
- () Slip a 4 1/2" length of sleeving over a 5" length of bare wire and connect one end to K2 (S).
- () Connect the remaining end of the bare wire to C1 (S).
- () Slip a 3" length of sleeving over a 4" length of bare wire and connect to K1 (S).
- () Connect the remaining end of the bare wire to A2 (S).
- () Slip 4 1/2" and 2 1/2" lengths of sleeving over a 7 1/2" length of bare wire and connect one end to R3 (S).
- () Connect the remaining end of bare wire to C7 (S).
- () Slip sleeving over a short length of bare wire, loop one end and solder to the bare wire just installed. (See Pictorial 1.)
- () Connect the remaining end to C5 (S).

REMAINING WIRING

- () Split the line cord about 4" from the end and fasten it to the voltmeter mounting bracket by means of a simple overhand knot. (See Pictorial 1.) The knot will provide strain relief.
- () One lead of the line cord connects to F1(S).
- () The other lead of the line cord connects to E2 (S).
- () Insert the fuse in the fuse holder.

Fasten the handle of the cabinet by means of the handle screws. Mount the four rubber feet as shown in Figure 6. Slide the assembled unit into the cabinet and fasten by means of six #6 sheet metal screws along the rim of the panel. Two additional #6 sheet metal screws through the back of the cabinet and into the bracket of the rectifier and condenser sub-chassis should also be installed. This completes the construction of the kit.

INITIAL TEST

The unit should now be checked carefully for proper operation. However, before turning the Battery Eliminator on, check over all the wiring. We suggest tracing over each wire on the pictorial with a colored pencil as it is checked on the instrument. Check each soldered connection.

Plug the unit into a 117 volt 50-60 cycle AC outlet only. This Battery Eliminator will not operate and serious damage will result if it is plugged into a DC outlet.

Set the voltage range switch to the 6 volt position. Leave the output terminals unconnected and turn the eliminator on. Rotate the voltage control and note that the output voltage indicated on the meter will vary from zero to over 10 volts. The ammeter will show no indication because no current is being drawn with the output unconnected.

Set the voltage range switch to the 12 volt position and again rotate the voltage control knob and note that the output voltage will vary from zero to well over 15 volts. Again there will be no indication of current flow on the ammeter because there is no load across the output terminals.

IMPORTANT WARNING

Do not change the setting of the voltage range switch while the Battery Eliminator is operating under load, as this will unnecessarily overload the switch contacts. Develop the habit of turning the eliminator off or disconnecting the load when changing voltages.

In all connections from the Battery Eliminator, use as heavy a wire as possible because of the large currents drawn. Never use wires which are not capable of easily carrying the currents involved.

When using the Battery Eliminator, make certain that air is free to circulate around the cabinet so that the rectifier will not be damaged through excessive heating.

Do not operate the Battery Eliminator at loads greater than those indicated on the panel. Excessive overloading will damage the rectifier unit.

A blown fuse is usually a sign of overload and the device connected to the eliminator should be checked for short circuits. Never use greater than a 5 ampere fuse in the Battery Eliminator.

USE OF THE BATTERY ELIMINATOR

The Heathkit Model BE-4 Battery Eliminator provides a convenient source of either 6 or 12 volts DC for the servicing of car radios or similar equipment requiring a low voltage high current supply. This completely eliminates the necessity of keeping a storage battery on the service bench. Use of the Battery Eliminator is extremely simple and it is merely necessary to connect the radio under repair to the Battery Eliminator terminals.

With the radio on the work bench, connect the lead which went to the plus side of the battery to the plus BE terminal and the lead which went to the minus side of the battery to the BE minus terminal. Having made the proper connections set the voltage control knob to maximum counterclockwise. Turn the BE on and begin to increase the output by means of the voltage control.

While increasing the voltage output, watch the ammeter carefully to see if a high current is being drawn at low voltage. If this is true, a short in the unit under test is indicated. The BE should be turned off immediately and the car radio investigated as to the cause of the short.

Also, in checking car radios, it is a good policy to vary the output of the BE over the range of voltages which may actually be found in the car. For example, a vibrator which will start on voltage above 5.6 volts may be considered BAD and vibrators that start between 5.2 to 5.6 volts are DOUBTFUL inasmuch as they very likely will soon cause trouble. Vibrators should start by the time a voltage of 5.2 volts is applied.

NOTE: Depending on the size and length of connecting wire used (between BE and the car radio) and the amount of current drawn, the magnitude of the voltage drop across the connecting wire will be determined. This may be a fairly appreciable drop and should be considered. Actual voltage applied to the radio itself is the BE voltage minus the connecting wire voltage drop. However, with short connections and a heavy wire, it is completely satisfactory to neglect the drop across the connecting leads and consider the voltage at the car radio the same as the indicated on the BE voltmeter.

This testing of vibrators as to starting voltage should not be considered as absolutely positive proof that the vibrator is at fault, as other factors may be contributing to the operation. For example, the buffer condenser may be causing the difficulty.

Also, as an additional check on the car radio, it is often worthwhile to increase the BE output voltage to somewhat over the normal car operation voltage. This is done to see how the radio under test operates at higher voltages which are at times developed in a car electrical system. To make this check, turn the BE output up to 8 or 8.5 volts and observe operation of the car radio. In this way, sometimes erratic or intermittent operation of the radio will be disclosed.

Auto radios with push button mechanisms often require momentary high currents and therefore the BE output should be turned to 8 volts or higher before operating the mechanism. Some car radios with motor driven systems will require initial surges of power that are beyond the capability of the BE. This does not necessarily constitute a fault in the motor mechanism and should be taken into consideration when servicing car radios with a BE.

CHARGING

The Battery Eliminator can also be used to charge storage batteries. The procedure is straightforward, but a few simple rules should be observed. If you are not certain that the battery needs a charge, check the cells with a hydrometer.

If charging is needed, operation is as follows: If the battery is in a car it need not be taken out, but be certain that all car ignition switches and controls are turned off. Unscrew the battery cell caps as a precaution against building up a pressure in the battery during the charging process. (A protection in case the vent holes might be clogged.) Connect the positive BE terminal to the positive terminal of the battery. Connect the negative terminal of the BE to the

negative terminal of the battery. Be sure to use large size wire. Large battery clips afford a convenient method for making the actual connection to the battery terminals.

Turn the voltage control maximum counterclockwise. Select the setting of the voltage range switch for the type of battery being charged. That is either 6 V. or 12 V. Plug in the BE and switch it on. If the ammeter reads backwards, it will read correctly as voltage is increased. Increase the voltage control until the battery is drawing a charging current from the BE. For a heavy charge, increase the voltage control until the battery is drawing a maximum of 10 amperes.

Time permitting a slower charge is recommended. An 8 to 10 hour charge of about 5 amperes is usually sufficient and the slower charge is generally considered to be better for the battery. Using the hydrometer will indicate when the battery is charged.

Be sure to follow all warnings and make certain that no shorting between output leads and the car chassis can occur. Upon completion of the charge, screw the cell caps down. As a word of precaution, be sure to disconnect the Battery Eliminator before starting the car.

CIRCUIT DESCRIPTION

Circuit operation of the kit is extremely simple and a brief description follows:

The AC voltage input is fed into the primary of the power transformer. The secondary of the transformer is of the direct contact to transformer winding type and is so wound that turning the winding contactor clockwise increases the amount of useful secondary winding turns and thus the amount of voltage output which can be obtained. The AC output of the transformer is connected to the rectifier in a full wave bridge circuit. By means of the rectifier bridge circuit, DC output is obtained and the 10,000 μ fd condensers filter the output to a clean DC. Setting the panel switch to the 12 volt position changes the circuit from a full wave bridge, to a voltage doubler to provide the necessary higher voltage range.

The overload relay is of the self-resetting type and is provided to protect the rectifier from damage in the event of an overload. The overload passing through a bimetal strip heats it and causes it to bend and thereby opens the circuit. Upon cooling, the bimetal strip again closes the circuit and thus the self-resetting feature is accomplished.

Both DC voltage and DC current output are continuously metered for convenience in operation. Care should be exercised to not operate the unit over rated output as the rectifier can be seriously damaged or completely ruined with excessive current drain.

IN CASE OF DIFFICULTY

1. Recheck the wiring. Most cases of trouble result from wrong or reversed connections. Often having a friend check the wiring will reveal a mistake consistently overlooked.
2. If either of the meters read backwards, the connections to them have probably been reversed and should be checked. If the meter leads are found to be correct, check the wiring to the output terminals.
3. If no output voltage whatever can be obtained, but a heavy current drain is indicated, check the output terminals for a short to the panel. If no output voltage or current can be obtained, make sure that the AC power lead is properly connected. See if a short has occurred which has blown the fuse. If so, correct the shorted condition and replace the fuse.

REPLACEMENTS

Material supplied with Heathkits has been carefully selected to meet design requirements and ordinarily will fulfill its function without difficulty. Occasionally improper instrument operation can be traced to a faulty tube or component. Should inspection reveal the necessity for replacement, write to the Heath Company and supply all of the following information:

- A. Thoroughly identify the part in question by using the part number and description found in the manual parts list.
- B. Identify the type and model number of kit in which it is used.
- C. Mention the order number and date of purchase.
- D. Describe the nature of defect or reason for requesting replacement.

The Heath Company will promptly supply the necessary replacement. Please do not return the original component until specifically requested to do so. Do not dismantle the component in question as this will void the guarantee. If tubes are to be returned, pack them carefully to prevent breakage in shipment as broken tubes are not eligible for replacement. This replacement policy does not cover the free replacement of parts that may have been broken or damaged through carelessness on the part of the kit builder.

SERVICE

In event continued operational difficulties of the completed instrument are experienced, the facilities of the Heath Company Service Department are at your disposal. Your instrument may be returned for inspection and repair for a service charge of \$3.00 plus the cost of any additional material that may be required. **THIS SERVICE POLICY APPLIES ONLY TO COMPLETED INSTRUMENTS CONSTRUCTED IN ACCORDANCE WITH THE INSTRUCTIONS AS STATED IN THE MANUAL.** Instruments that are not entirely completed or instruments that are modified in design will not be accepted for repair. Instruments showing evidence of acid core solder or paste fluxes will be returned not repaired.

The Heath Company is willing to offer its full cooperation to assist you in obtaining the proper operation of your instrument and therefore this factory repair service is available for a period of one year from the date of purchase.

SHIPPING INSTRUCTIONS

Before returning a unit for service, be sure that all parts are securely mounted. Attach a tag to the instrument giving name, address and trouble experienced. Pack in a rugged container, preferably wood, using at least three inches of shredded newspaper or excelsior on all sides. **DO NOT SHIP IN THE ORIGINAL KIT CARTON AS THIS CARTON IS NOT CONSIDERED ADEQUATE FOR SAFE SHIPMENT OF THE COMPLETED INSTRUMENT.** Ship by prepaid express if possible. Return shipment will be made by express collect. Note that a carrier cannot be held liable for damage in transit if packing, in HIS OPINION, is insufficient.

SPECIFICATIONS

All prices are subject to change without notice. The Heath Company reserves the right to discontinue instruments and to change specifications at any time without incurring any obligation to incorporate new features in instruments previously sold.

WARRANTY

The Heath Company limits its warranty of parts supplied with any kit (except tubes, meters and rectifiers, where the original manufacturer's guarantee only applies) to a period of three (3) months from the date of purchase. Replacement will be made only when said part is returned postpaid, with prior permission and in the judgment of the Heath Company was defective at the time of sale. This warranty does not extend to any Heathkits which have been subjected to misuse, neglect, accident and improper installation or applications. Material supplied with a kit shall not be considered as defective, even though not in exact accordance with specifications, if it substantially fulfills performance requirements. This warranty is not transferable and applies only to the original purchaser. This warranty is in lieu of all other warranties and the Heath Company neither assumes nor authorizes any other person to assume for them any other liability in connection with the sale of Heathkits.

The assembler is urged to follow the instructions exactly as provided. The Heath Company assumes no responsibility for the operation of the completed instrument, nor liability for any damages or injuries sustained in the assembly or operation of the device.

HEATH COMPANY Benton Harbor, Michigan

WIRING OF EXPORT TYPE 110/220 VOLT POWER TRANSFORMERS

These transformers have a dual primary for use on either 110 Volts or 220 Volts.
Wire as shown.

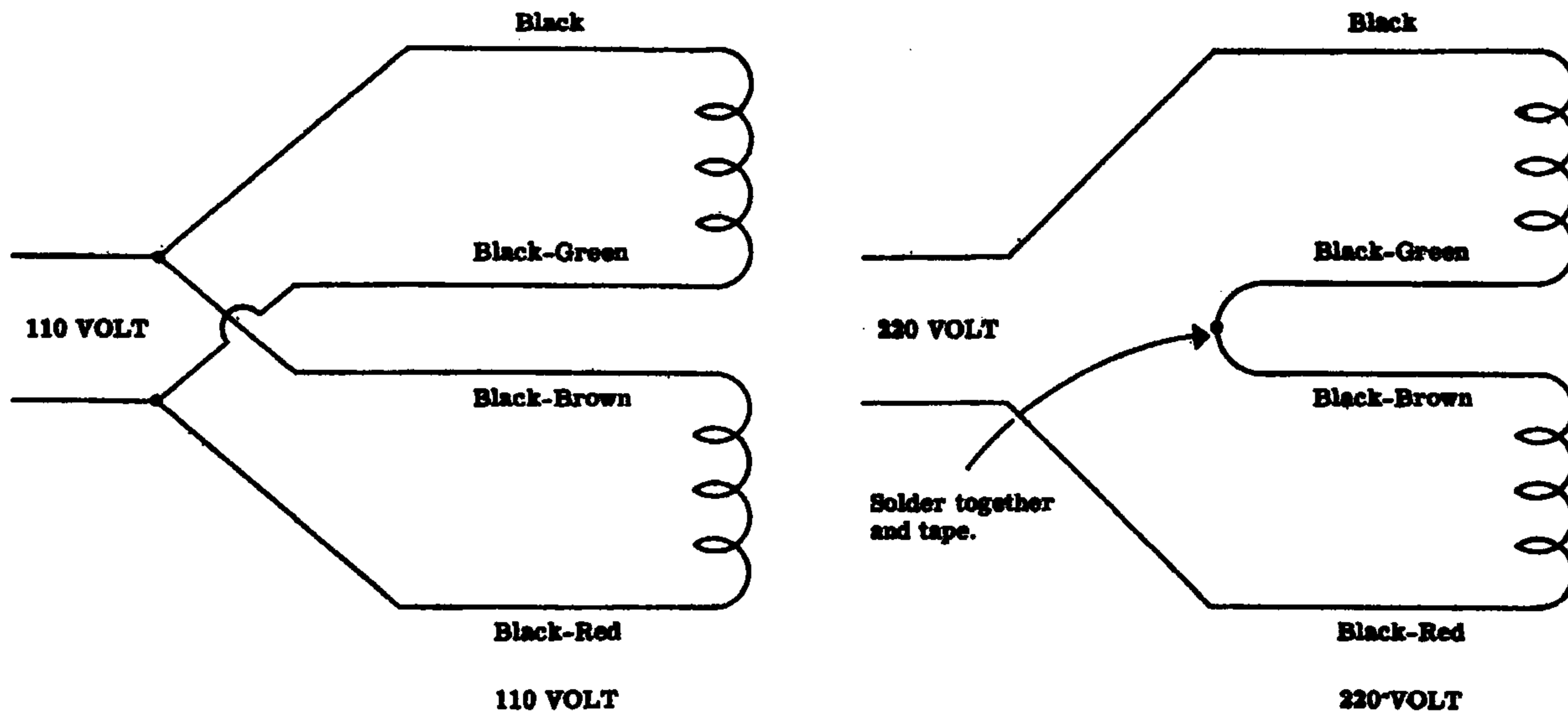

PARTS LIST
HEATHKIT BATTERY ELIMINATOR
MODEL BE-4

| <u>PART No.</u> | <u>PARTS Per Kit</u> | <u>DESCRIPTION</u> | <u>PART No.</u> | <u>PARTS Per Kit</u> | <u>DESCRIPTION</u> |
|-------------------------|----------------------|--|----------------------|----------------------|---------------------------|
| Basic Components | | | Miscellaneous | | |
| 25-15 | 2 | 10,000 μ fd 10V DC condenser | 89-1 | 1 | Line cord |
| 54-12 | 1 | Transformer | 253-13 | 2 | #8 shoulder fiber washer |
| 57-10 | 1 | Rectifier | 253-14 | 2 | #8 flat fiber washer |
| 60-1 | 1 | Switch | 261-1 | 4 | Rubber feet |
| 63-51 | 1 | 6-12V rotary switch | 340-1 | 4 | length #16 bare wire |
| 65-1 | 1 | Overload switch | 344-1 | 1 | length Hookup wire |
| 407-3 | 1 | 0-15V DC voltmeter | 346-1 | 2 | length Insulated sleeving |
| 407-11 | 1 | 0-15A DC ammeter | 421-2 | 1 | 3A fuse |
| 469-1 | 1 | Transformer winding contactor | 423-1 | 1 | Fuse holder |
| Metal Parts | | | 426-2 | 2 | Binding post |
| 90-4 | 1 | Cabinet | 462-M11 | 2 | Pointer knob |
| 203-M29F37 | 1 | Panel | 595-59 | 1 | Manual |
| 204-M27 | 1 | Wide Z bracket | | | |
| 204-M28 | 1 | Narrow Z bracket | | | |
| 200-M46 | 1 | Condenser mounting sub-chassis | | | |
| 207-2 | 2 | Mounting clamp for 10,000 μ fd condenser | | | |
| 211-1 | 1 | Handle | | | |
| Hardware | | | | | |
| 250-8 | 10 | 6-3/8 sheet metal screw | | | |
| 250-9 | 12 | 6-32 x 3/8 screw | | | |
| 250-13 | 2 | 6-32 x 1 screw | | | |
| 250-19 | 2 | 10-24 handle screw | | | |
| 250-22 | 2 | Headless set screw for knob | | | |
| 252-3 | 14 | 6-32 x 1/4 nut | | | |
| 252-4 | 2 | 8-32 x 3/8 nut | | | |
| 252-5 | 2 | 10-32 x 3/8 nut | | | |
| 252-7 | 2 | Control nut | | | |
| 252-13 | 2 | 5/16-24 hex nut | | | |
| 252-14 | 4 | 8-32 hex cap nut | | | |
| 253-9 | 5 | 3/8 nickel washer | | | |
| 253-10 | 2 | Control nickel washer | | | |
| 253-18 | 1 | Control washer | | | |
| 254-1 | 14 | #6 lockwasher | | | |
| 254-3 | 1 | #10 lockwasher | | | |
| 254-4 | 4 | Control lockwasher | | | |
| 255-4 | 1 | #10 x 3/8 spacer | | | |
| 259-2 | 2 | #8 solder lug | | | |
| 259-5 | 1 | #10 solder lug | | | |
| 455-3 | 1 | Bushing | | | |

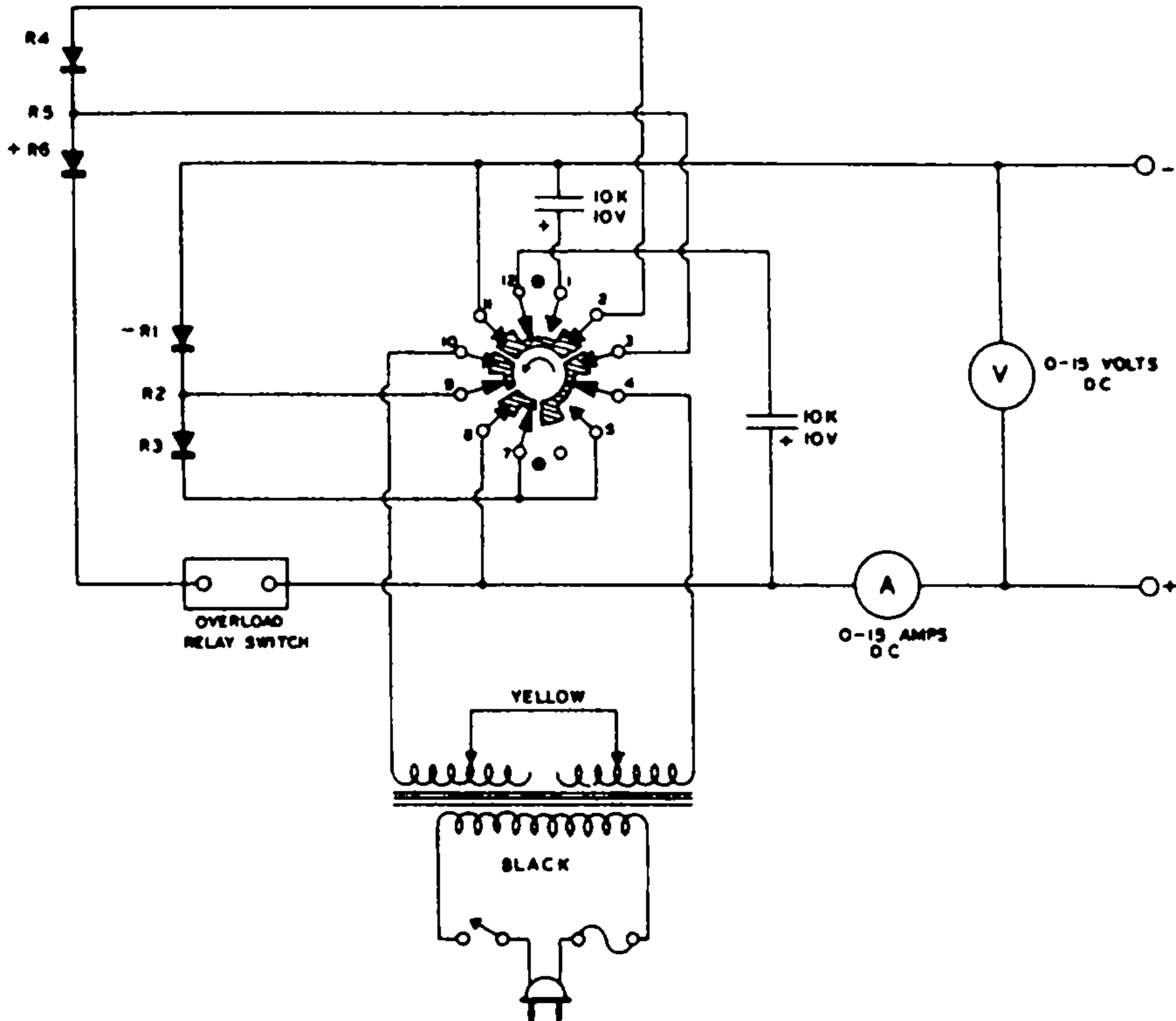

HELPFUL KIT BUILDING INFORMATION

Before attempting actual kit construction read the construction manual through thoroughly to familiarize yourself with the general procedure. Note the relative location of pictorials and pictorial inserts in respect to the progress of the assembly procedure outlined.

This information is offered primarily for the convenience of novice kit builders and will be of definite assistance to those lacking thorough knowledge of good construction practices. Even the advanced electronics enthusiast may benefit by a brief review of this material before proceeding with kit construction. In the majority of cases, failure to observe basic instruction fundamentals is responsible for inability to obtain desired level of performance.

RECOMMENDED TOOLS

The successful construction of Heathkits does not require the use of specialized equipment and only basic tools are required. A good quality electric soldering iron is essential. The preferred size would be a 100 watt iron with a small tip. The use of long nose pliers and diagonal or side cutting pliers is recommended. A small screw driver will prove adequate and several additional assorted screw drivers will be helpful. Be sure to obtain a good supply of rosin core type radio solder. Never use separate fluxes, paste or acid solder in electronic work.

ASSEMBLY

In the actual mechanical assembly of components to the chassis and panel, it is important that the procedure shown in the manual be carefully followed. Make sure that tube sockets are properly mounted in respect to keyway or pin numbering location. The same applies to transformer mountings so that the correct transformer color coded wires will be available at the proper chassis opening.

Make it a standard practice to use lock washers under all 6-32 and 8-32 nuts. The only exception being in the use of solder lugs—the necessary locking feature is already incorporated in the design of the solder lugs. A control lock washer should always be used between the control and the chassis to prevent undesirable rotation in the panel. To improve instrument appearance and to prevent possible panel marring use a control flat nickel washer under each control nut.

When installing binding posts that require the use of fiber insulating washers, it is good practice to slip the shoulder washer over the binding post mounting stud before installing the mounting stud in the panel hole provided. Next, install a flat fiber washer and a solder lug under the mounting nut. Be sure that the shoulder washer is properly centered in the panel to prevent possible shorting of the binding post.

WIRING

When following wiring procedure make the leads as short and direct as possible. In filament wiring requiring the use of a twisted pair of wires allow sufficient slack in the wiring that will permit the twisted pair to be pushed against the chassis as closely as possible thereby affording relative isolation from adjacent parts and wiring.

When removing insulation from the end of hookup wire, it is seldom necessary to expose more than a quarter inch of the wire. Excessive insulation removal may cause a short circuit condition in respect to nearby wiring or terminals. In some instances, transformer leads of solid copper will have a brown baked enamel coating. After the transformer leads have been trimmed to a suitable length, it is necessary to scrape the enamel coating in order to expose the bright copper wire before making a terminal or soldered connection.

In mounting parts such as resistors or condensers, trim off all excess lead lengths so that the parts may be installed in a direct point-to-point manner. When necessary use spaghetti or insulated sleeving over exposed wires that might short to nearby wiring.

It is urgently recommended that the wiring dress and parts layout as shown in the construction manual be faithfully followed. In every instance, the desirability of this arrangement was carefully determined through the construction of a series of laboratory models.

SOLDERING

Much of the performance of the kit instrument, particularly in respect to accuracy and stability, depends upon the degree of workmanship used in making soldered connections. Proper soldered connections are not at all difficult to make but it would be advisable to observe a few precautions. First of all before a connection is to be soldered, the connection itself should be clean and mechanically strong. Do not depend on solder alone to hold a connection together. The tip of the soldering iron should be bright, clean and free of excess solder. Use enough heat to thoroughly flow the solder smoothly into the joint. Avoid excessive use of solder and do not allow a flux flooding condition to occur which could conceivably cause a leakage path between adjacent terminals on switch assemblies and tube sockets. This is particularly important in instruments such as the VTVM, oscilloscope and generator kits. Excessive heat will also burn or damage the insulating material used in the manufacture of switch assemblies. Be sure to use only good quality rosin core radio type solder.

| | | | | | | | |
|-------------------------------------|--|---|--|---------------------------------------|------------------------------------|---|--|
| Antenna General | | Resistor General | | Neon Bulb | | Receptacle two-conductor | |
| Loop | | Resistor Tapped | | Illuminating Lamp | | Battery | |
| Ground | | Resistor Variable | | Switch Single pole Single throw | | Fuse | |
| Inductor General | | Potentiometer | | Switch double pole single throw | | Piezoelectric Crystal | |
| Air core Transformer General | | Thermistor | | Switch Triple pole Double throw | | 1000 = K | |
| Adjustable Powdered Iron Core | | Jack two conductor | | Switch Multipoint or Rotary | | 1,000,000 = M | |
| Magnetic Core Variable Coupling | | Jack three conductor | | Speaker | | OHM = Ω | |
| Iron Core Transformer | | Wires connected | | Rectifier | | Microfarad = MF | |
| Capacitor General | | Wires Crossing but not connected | | Microphone | | Micro Microfarad = MMF | |
| Capacitor Electrolytic | | A. Ammeter V. Voltmeter | | Typical tube symbol | Binding post Terminal strip | Wiring between like letters is understood | |
| Capacitor Variable | | G. Galvanometer MA. Milliammeter uA. Microammeter, etc. | | | | | |

HEATH COMPANY
BENTON HARBOR, MICHIGAN

THE WORLD'S
Finest
TEST EQUIPMENT
IN KIT FORM