

**H**ave you ever experienced the frustration of turning on your battery-powered radio and finding out after only a few minutes of use that the battery needs recharging? If you only had a meter that told you how low the battery pack was getting the last time you used the radio, you could have recharged it between uses. The FuelGauge presented here is just the thing you need to monitor battery level and intelligently schedule recharges.

**Accurately Measuring Battery Capacity.** As the charge in a battery gets used up, the terminal voltage decreases. That is true for all types of batteries, including NiCd, lead-acid, nickel-metal-hydride, and even non-rechargeable alkaline or zinc-carbon cells. Each type of battery has its own characteristic curve, which can be used to find the percentage of charge left based on the terminal voltage. A typical curve, shown in Fig. 1, is for a 7-cell NiCd pack. By accurately measuring the voltage of a battery pack, the state of charge can be found by referring to the battery type's characteristic curve. The FuelGauge does that calculation for you automatically.

Accuracy and high sensitivity is extremely important because the voltage change is small compared to the total battery voltage. The voltage reading of a completely discharged battery is almost as high as the voltage when the battery is charged. For that reason, the FuelGauge's circuit features a suppressed-zero method for driving the meter. The meter will read full scale for a fully-charged battery, while dropping down to zero when the battery is completely discharged. That feature allows for the meter to read percent full on a linear scale with 100% at the right, 50% in the center, and 0% at the left.

A second requirement for the circuit is low power drain. It doesn't make much sense to put a charge monitor on a battery pack if it will be a big drain. The FuelGauge is designed to draw just a little more than the current needed to move the meter needle itself. The total drain to run the FuelGauge is less than 2 milliamps when measuring a full charge.

# BUILD THE FUEL GAUGE— A CAPACITY INDICATOR FOR YOUR BATTERY PACK

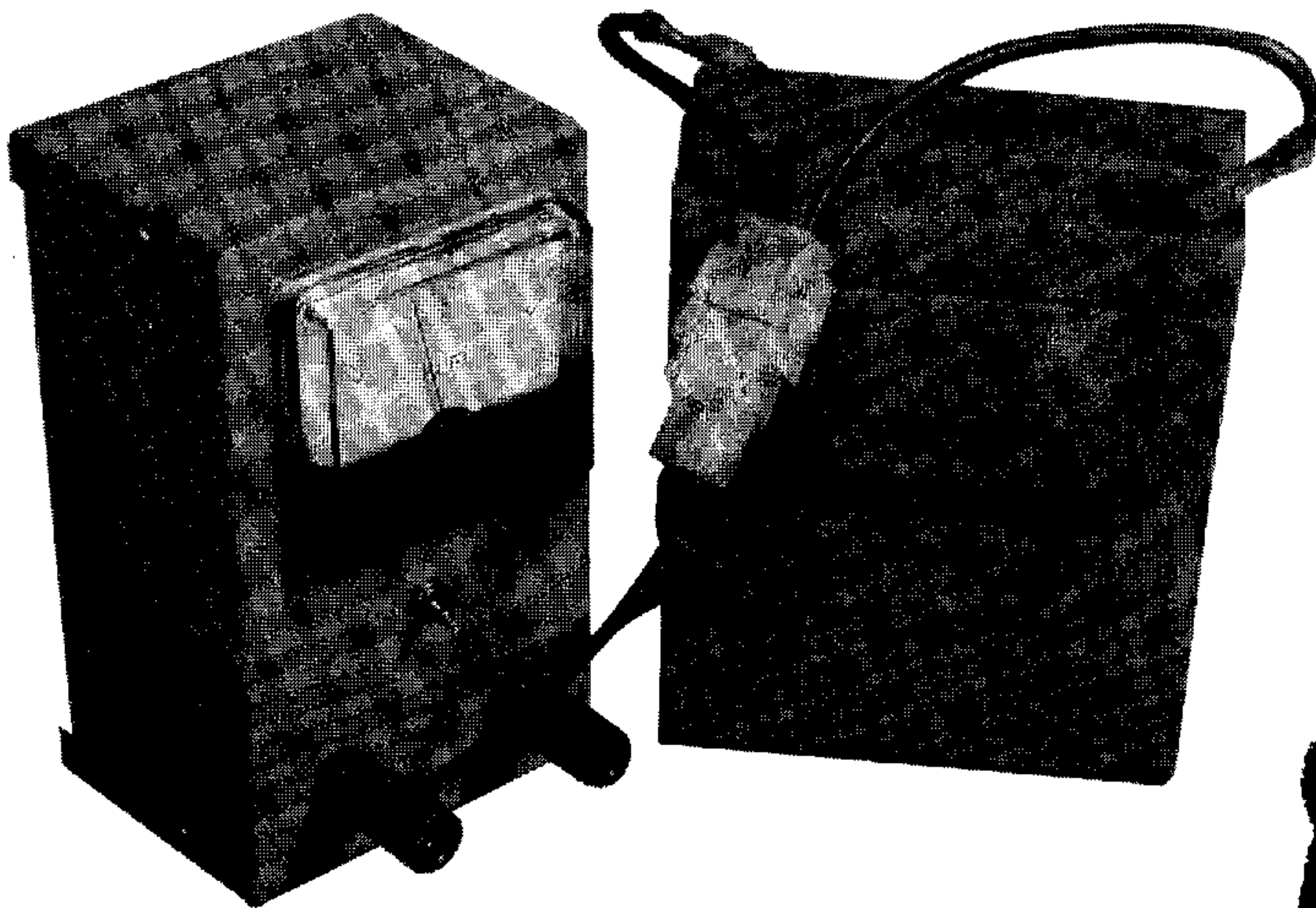

*Know how much charge is left in your batteries with this easy-to-build project.*

**Circuit Description.** The circuit that the FuelGauge is based on is shown in Fig. 2. Zener diode D1 creates a reference voltage to which the battery voltage is compared. The diode specified has a breakdown voltage of

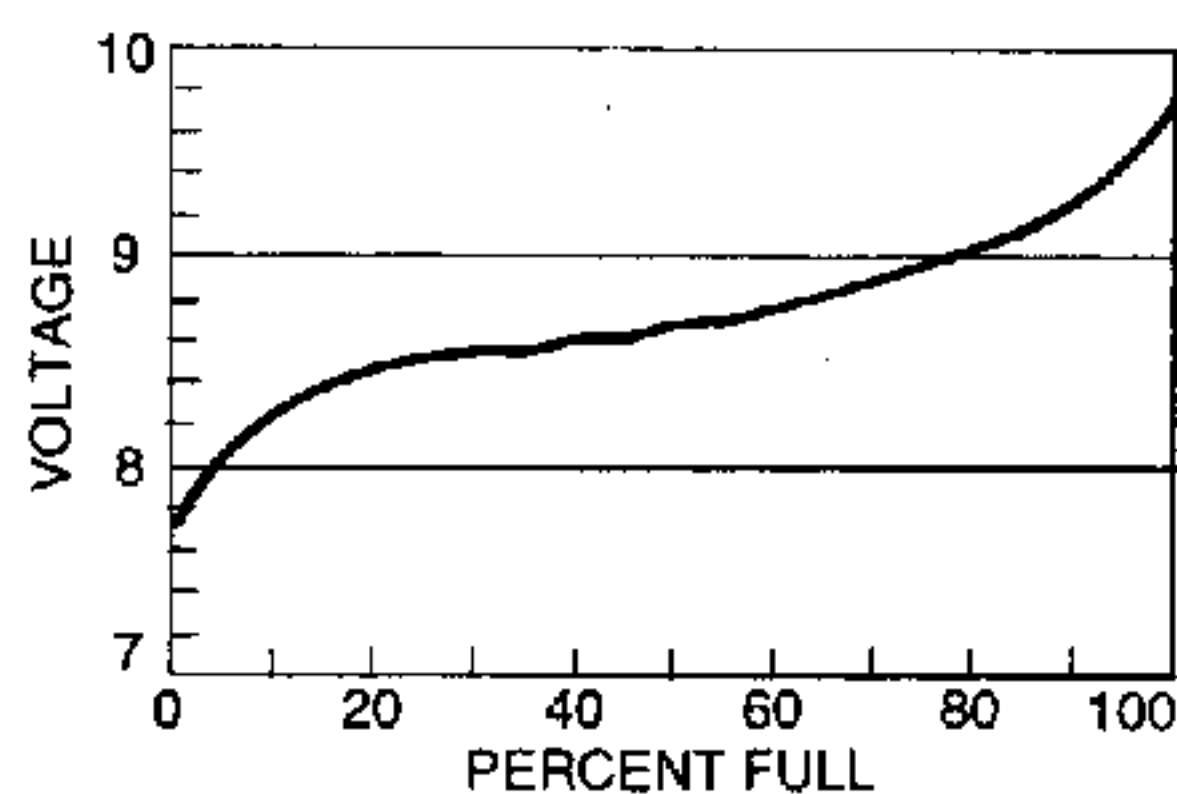

*Fig. 1. All batteries have a characteristic discharge curve like this one. If you measure the no-load voltage of a battery and look up the reading on the battery's discharge curve, you will have an accurate way of measuring how much charge is left in the battery.*

5.1 volts. That rating will work fine with most 6- or 7-cell NiCd battery packs, as well as 12-volt lead-acid batteries. The circuit may be customized to a particular battery by selecting a unit for D1 that has a voltage rating about 1 volt below the completely-discharged voltage of the battery pack you wish to measure.

Transistor Q1, wired as an emitter-follower amplifier, greatly increases the sensitivity of the circuit over what it would be if R7 were connected directly to the wiper of R6. A further advantage to that arrangement is in reducing the current drain that flows through R1, R2, and R6. By amplifying the current flowing through the resistors, the resistance value can be increased to a very high value, lowering the total current draw of the circuit. Resistor R6 adjusts the meter to read 0



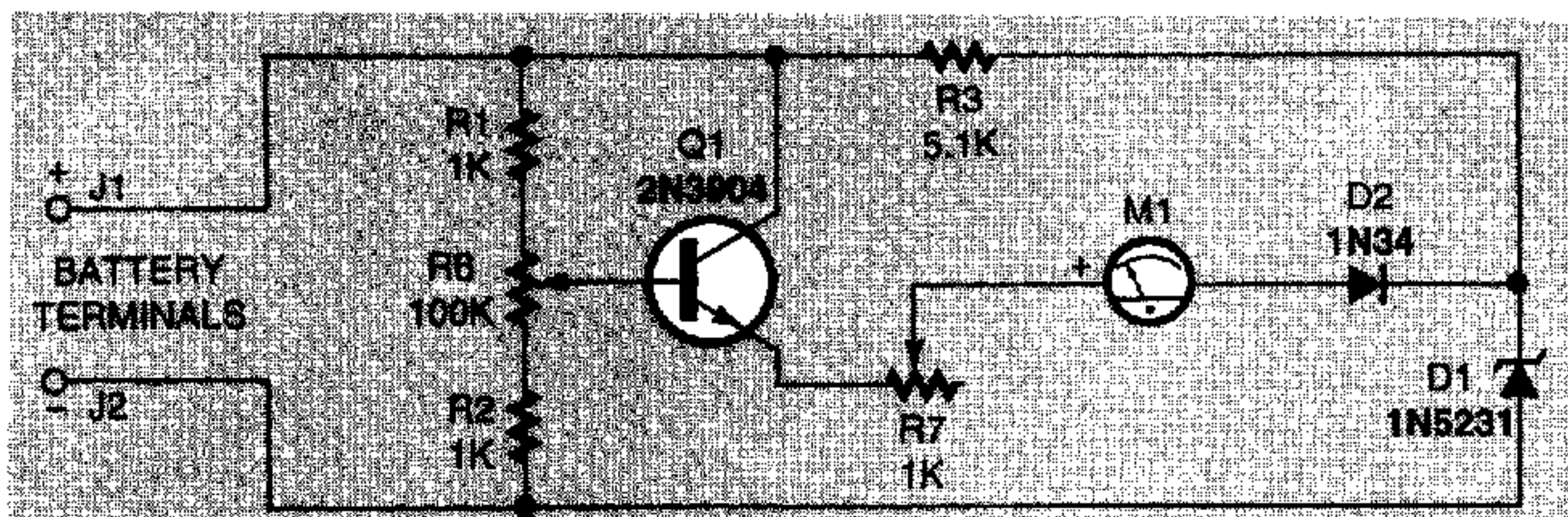

Fig. 2. Here's the basic circuit for the FuelGauge. Since the current flow through a resistor depends on the voltage, this circuit is a very sensitive voltmeter. Using a transistor to amplify the current flow through the resistors allows the circuit to be adjustable over a wide range without wasting any extra power.

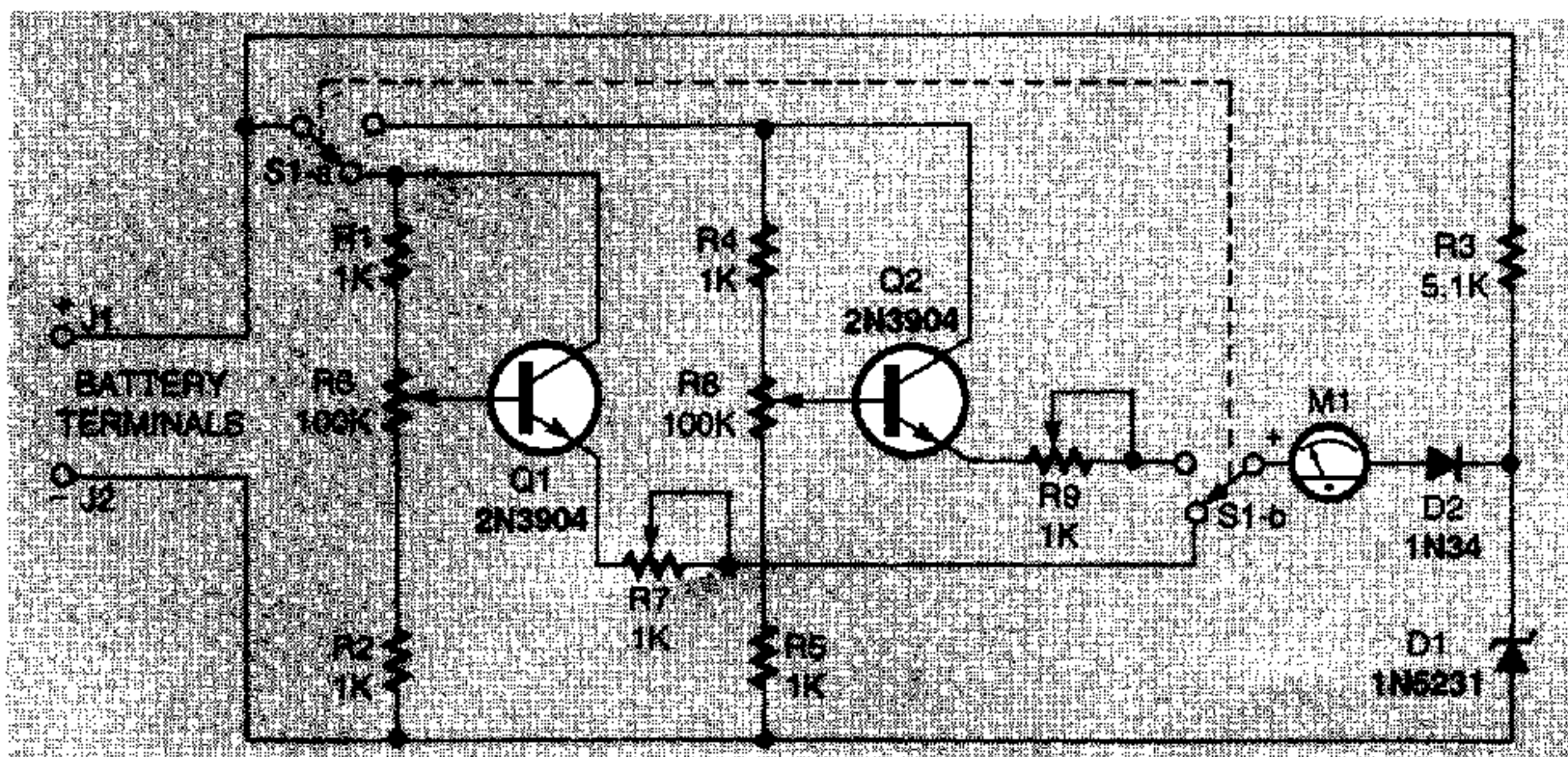

Fig. 3. The dual-use version of the FuelGauge consists of two basic circuits and a switch. Each circuit can be calibrated for a different type of battery, making the FuelGauge very versatile.

milliamps when the battery is completely discharged, and R7 adjusts the meter to read 1 milliamp when the battery is fully charged.

If the FuelGauge is accidentally connected backwards to the battery, current would flow through D1 and M1. The transistor would become reverse-biased, allowing a complete path back to the battery. That situation would allow excessive current to flow through D1, M1, and Q1, destroying them in the process. To protect the FuelGauge and the battery, D2, R1, and R2 are included to prevent any current flow in case the battery is reversed.

**A Dual-Use Meter.** The versatility of the FuelGauge can be increased by adding a second input circuit. That allows the unit to be calibrated for two different types of batteries. That circuit is shown in Figure 3. A double-pole, double-throw switch, S1, selects one of the two input circuit. One circuit is adjusted to one type of battery, and the other circuit is adjusted to a second type of battery. For instance, one position of S1 may be set to monitor the battery of a hand-held two-way radio, and the second position may be

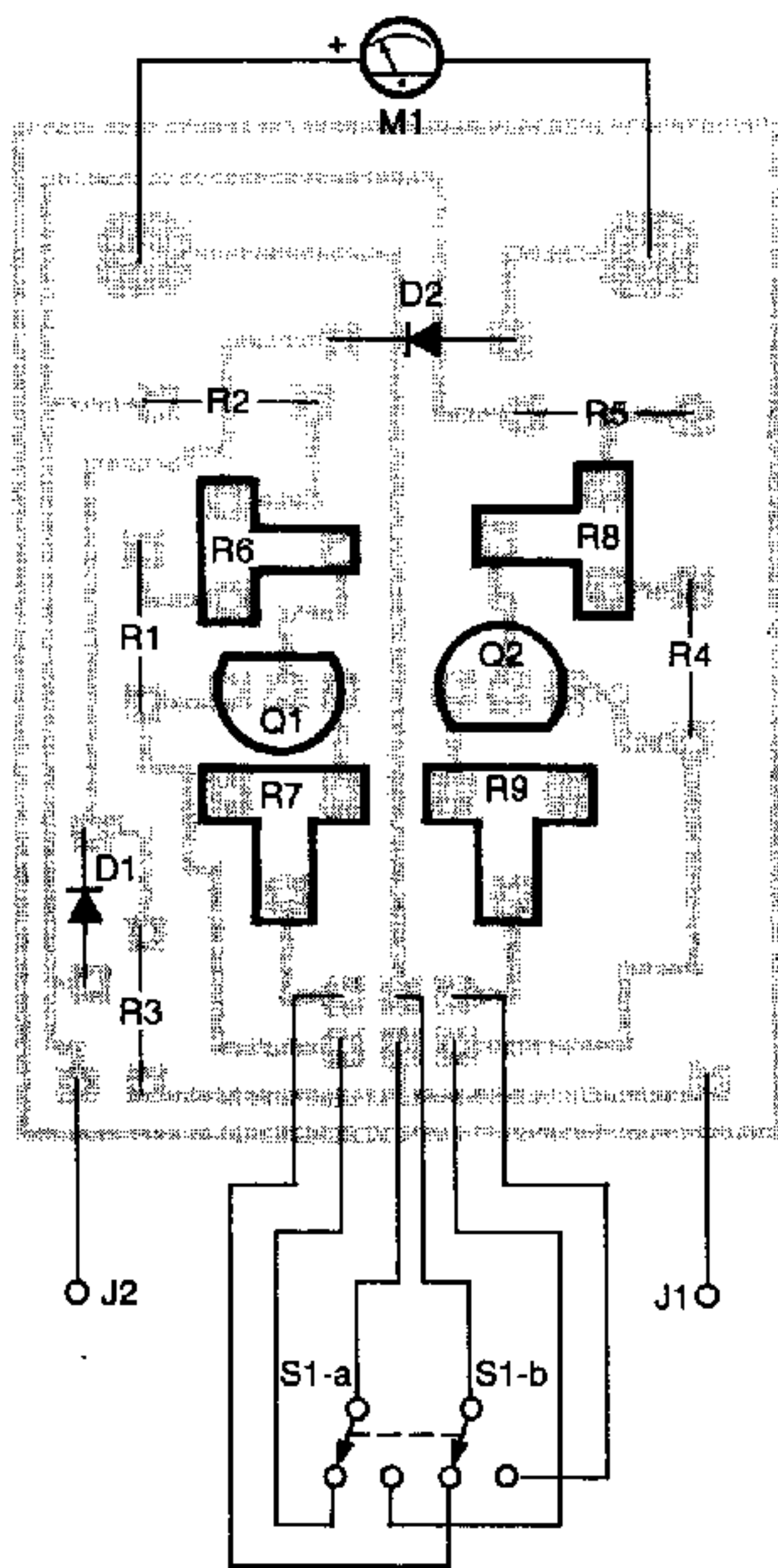

Fig. 4. Here's the parts-placement diagram for the dual-use version of the FuelGauge. If your panel meter's terminals are spaced the same distance as the pads of the PC board, you can mount the board directly to those terminals.

## PARTS LIST FOR THE BATTERY FUEL GAUGE

### RESISTORS

(All resistors are 1/4-watt, 5% units unless otherwise noted.)

R1, R2, R4, R5—1,000-ohm

R3—5,100-ohm

R6, R8—100,000-ohm,

potentiometer

R7, R9—1,000-ohm, potentiometer

### SEMICONDUCTORS

D1—1N5231 Zener diode

D2—1N34A germanium diode

Q1, Q2—2N3904, NPN transistor

### ADDITIONAL PARTS AND

#### MATERIALS

M1—Meter, analog, panel-mount, 0-1 milliamp DC

S1—DPDT toggle switch, panel-mount

J1—red binding post

J2—black binding post

PC board, case, insulated hookup wire, solder, etc.

**Note:** The following items are available from: Unicorn

Electronics, Inc., Valley Plaza

Drive, Johnson City, NY 13790,

Tel: 607-798-0250. Kit of all parts

(including all electronic

components, etched and drilled PC

board, drilled case, and meter with

fuel scale), \$35.95. Meter with

fuel scale, \$18.75. Etched and

drilled PC board, \$3.00. Please

add \$3.50 for shipping and

handling. Please send check or

money order with all orders. New

York State residents must add

appropriate sales tax.

used for a 12-volt lead-acid motorcycle battery.

**Construction.** The FuelGauge's circuit is simple enough to wire up using standard perfboard. If you wish to use a PC board, a foil pattern for a single-sided board has been supplied. A feature of the PC board pattern is the location of the connection pads for the meter. They are positioned for mounting the PC board directly to the screw terminals of a standard panel-mount meter. As an alternative, you may connect the board to the meter by wires, and mount the board separately in an enclosure.

If you use the foil pattern for a PC board, or buy one from the source given in the Parts List, use the parts—  
(Continued on page 74)



## BATTERY FUEL GAUGE

(Continued from page 59)

placement diagram in Fig. 4 as a guide. The pattern shown is for the dual-use version; should you wish to build a single-use version, simply eliminate R4, R5, R8, R9, and Q2. Obviously, a single-use version will not need S1, either. Appropriate jumpers should then be inserted in the locations where switch S1 would normally be connected.

A small metal box measuring 5 inches  $\times$  3 inches  $\times$  2- $\frac{1}{4}$  inches will hold all of the parts comfortably. The most difficult part of the construction is cutting a suitable hole in the box for the meter. One method that works well is using an adjustable hole-drilling bit with an ordinary  $\frac{1}{4}$ -inch electric drill. If you do not like metal cutting, a kit containing a pre-drilled case is available from the source given in the Parts List.

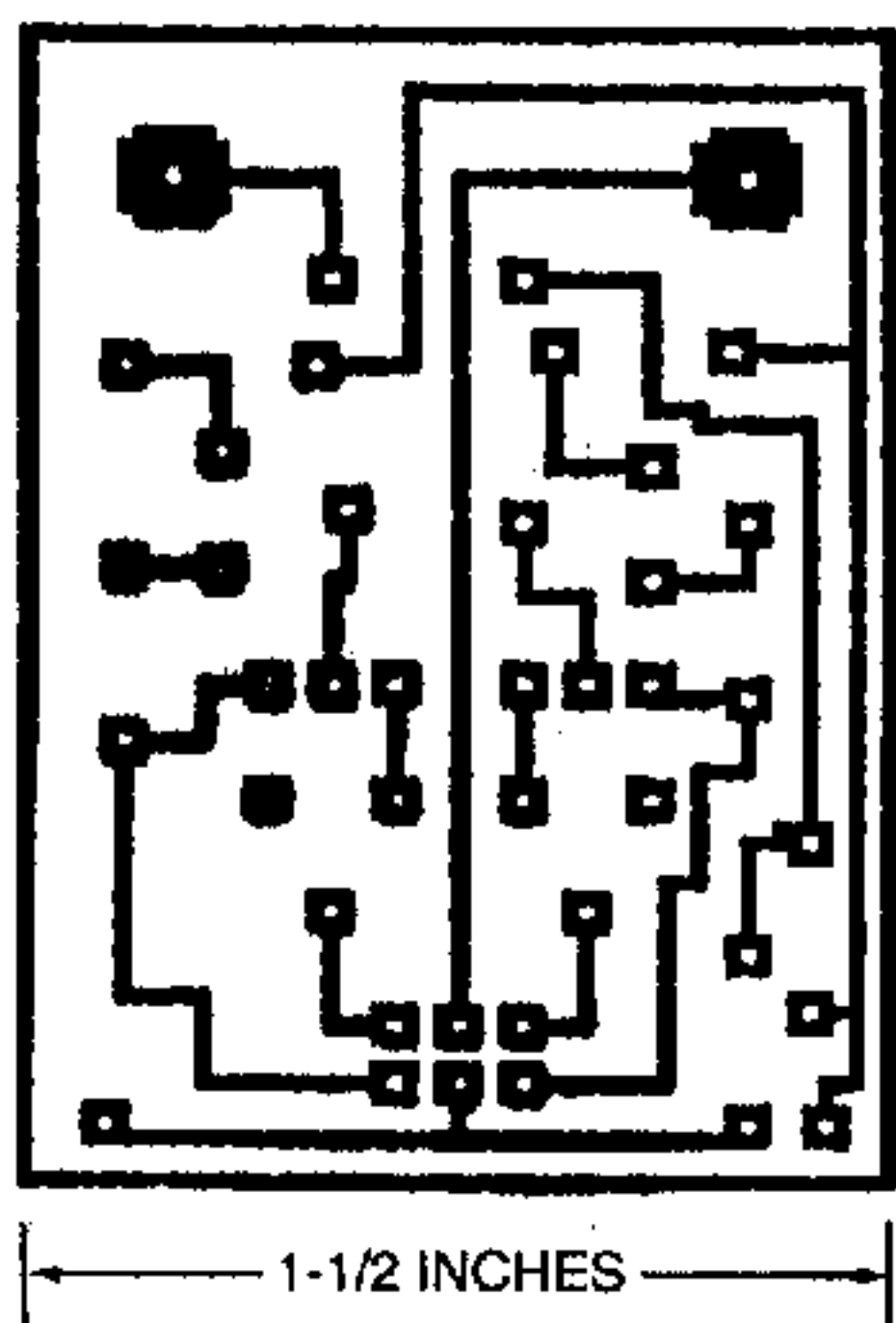

*Here's the foil pattern for the FuelGauge. Two independent circuits fit easily onto this single-sided board.*

The markings on a 1-milliamp analog panel meter can be read as percentages of battery charge left. If you'd like to dress up the meter face, you could draw a replacement scale on a self-adhesive label. One possible style is an automotive fuel gauge. The size of the replacement scale should be the same size as the scale of the meter you are using for the FuelGauge.

**Battery Contacts.** You will have to use your ingenuity to find the best way to connect the FuelGauge to your particular battery. One example is

certain models of batteries used by Icom transceivers. Those have an extra set of contacts on the back that are meant for use by an optional fast charger. To use those contacts, you will need brass strips,  $\frac{1}{4}$ -inch wide, which are available at hobby shops. The strips are bent to fit around the bottom of the battery. A solder blob on one end serves to make connection with the spare battery contacts. An 18-inch length of hook-up wire with a banana plug on one end is soldered to the other end of the brass strip for connection to the FuelGauge.

**Calibration.** The FuelGauge is calibrated by first connecting it to the battery you'd like to use it with when the battery is fully discharged. Assuming you are using the dual-circuit version of the FuelGauge, select which circuit will be used with S1. Adjust R6 (or R8) to the point where the meter first starts to indicate (just a hair above the empty mark). Disconnect the FuelGauge and fully recharge the battery. Remove the charger, reconnect the FuelGauge, and set R7 (or R9) for a full scale reading (just at the full mark). If you are going to use the dual-use version of the FuelGauge with another type of battery, repeat the calibration procedure with the other battery and S1 in its other position.

The FuelGauge is now ready for use with that battery (or batteries). Remember that the FuelGauge draws between 1 and 2 milliamps from the battery when in use. While in some applications you may leave the FuelGauge connected, on smaller battery packs or over extended periods you may want to eliminate that small drain by disconnecting the FuelGauge or adding a switch in series with the terminal connections.

There you have it—a highly-accurate fuel gage for your battery packs that will have paid for itself the first time you *don't* mistakenly try to use a battery pack that is almost discharged. You'll get a lot of satisfaction and peace of mind always knowing the state of charge of your battery pack.

Ω