

OP-AMP OSCILLATORS

Op-amp oscillators give good vibrations.

RAY MARSTON

OP-AMPS CAN BE USED TO GENERATE SINE-wave, triangular-wave, and square-wave signals. We'll start by discussing the theory behind designing op-amp oscillators. Then we'll examine methods to stabilize oscillator circuits using thermistors, diodes, and small incandescent lamps. Finally, our discussion will round off with designing bi-stable op-amp switching circuits.

Sine-wave oscillator

In Fig. 1, an op-amp can be made to oscillate by feeding a portion of the output back to the input via a frequency-selective network, and controlling the overall voltage gain.

For optimum sine-wave generation, the frequency-selective network must feed back an overall phase shift of zero degrees, while the gain network provides unity amplification at the desired oscillation frequency. The frequency network often has a negative gain, which must be compensated for by additional amplification in the gain network, so that the total gain is unity. If the overall gain is less than unity, the circuit will not oscillate; if the overall gain is greater than unity, the output waveform will be distorted.

As Fig. 2 shows, a Wien-bridge network is a practical way of implementing a sine-wave oscillator. The frequency-selective Wien-bridge is constructed from the R1-C1 and R2-C2 networks. Normally, the Wien bridge is symmetrical, so that $C1 = C2 = C$ and $R1 = R2 = R$. When that condition is met, the phase relationship between the output and input signals varies from -90° to $+90^\circ$, and is precisely 0° at a center frequency, f_0 , which can be calculated using this formula:

$$f_0 = 1/(2\pi CR)$$

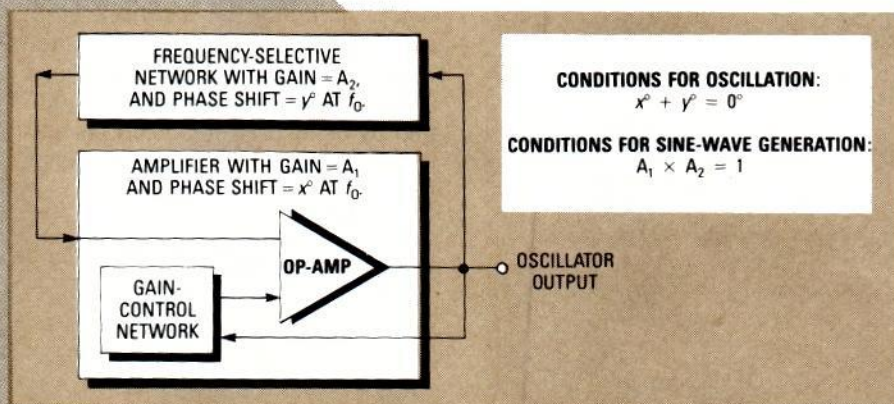

FIG. 1—STABLE SINE-WAVE OSCILLATION requires a zero phase shift between the input and output, and an overall gain of 1.

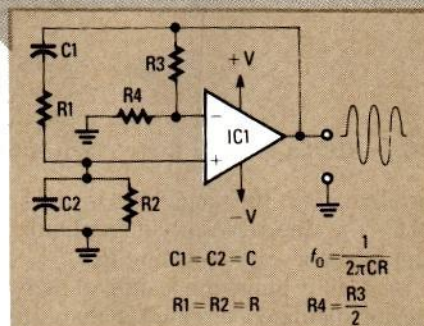

FIG. 2—BASIC WEIN-BRIDGE sine-wave oscillator.

The Wien network is connected between the op-amp's output and the non-inverting input, so that the circuit gives zero overall phase shift at f_0 , where the voltage gain is 0.33; therefore, the op-amp must be given a voltage gain of 3 via feedback network R3-R4, which gives an overall gain of unity. That satisfies the basic requirements for sine-wave oscillation. In practice, however, the ratio of R3 to R4 must be carefully adjusted to give the overall voltage gain of precisely unity, which is necessary for a low-distortion sine wave.

Op-amps are sensitive to temperature variations, supply-voltage fluctuations, and other conditions that cause the op-amp's output voltage to vary. Those voltage fluctuations across components R3-R4 will also

cause the voltage gain to vary. The feedback network can be modified to give automatic gain adjustment (to increase amplifier stability) by replacing the passive R3-R4 gain-determining network with a gain-stabilizing circuit. Figures 3 through 7 show practical versions of Wien-bridge oscillators having automatic amplitude stabilization.

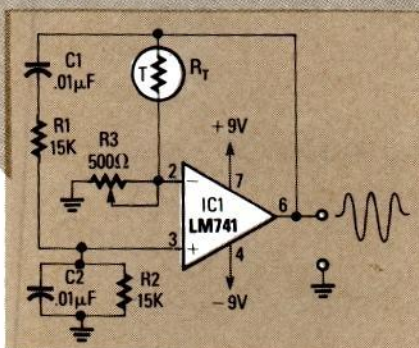

FIG. 3—THERMISTOR-STABILIZED 1-kHz Wien-bridge oscillator.

Thermistor stabilization

Figure 3 shows a 1-kHz fixed-frequency oscillator. The output amplitude is stabilized by a Negative Temperature Coefficient (NTC) thermistor R_T which, together with R3 forms a gain-determining feedback network. The thermistor is heated by the mean power output of the op-amp.

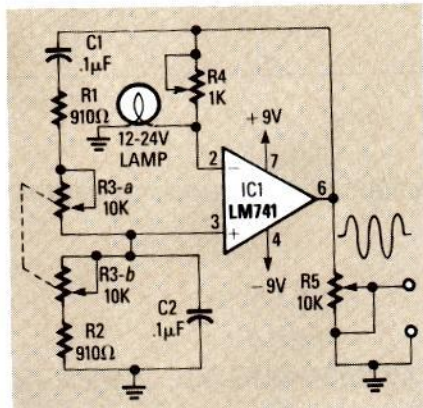

FIG. 4—LAMP-STABILIZED Wien-bridge oscillator.

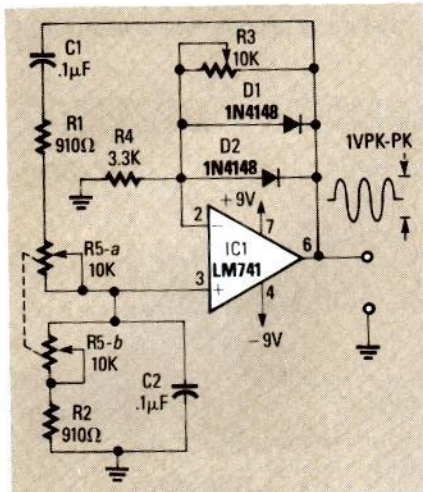

FIG. 5—DIODE-REGULATED Wien-bridge oscillator.

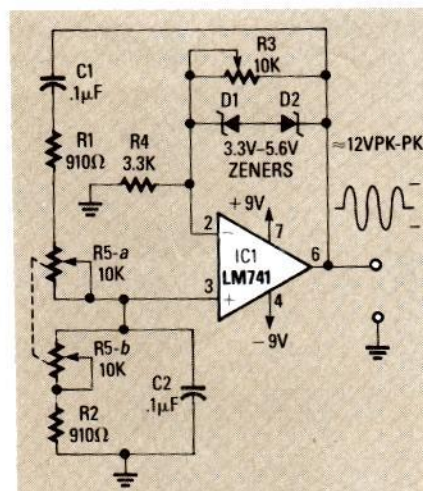

FIG. 6—ZENER-REGULATED Wien-bridge oscillator.

The desired feedback thermistor resistance value is triple that of R3, so the feedback gain is $\times 3$. When the feedback gain is multiplied by the frequency network's gain of 0.33, the overall gain becomes unity. If the oscillator output amplitude starts to rise, R_T heats up and reduces its resistance, thereby automatically reducing

the gain of the circuit, which stabilizes the amplitude of the output signal.

An alternative method of thermistor stabilization is shown in Fig. 4. In that case, a low-current lamp is used as a Positive Temperature Coefficient (PTC) thermistor, and is placed in the lower part of the gain-determining feedback network. If the output amplitude increases, the lamp heats up thereby increasing its resistance, reducing the feedback gain, and providing automatic amplitude stabilization. That circuit also shows how the Wien network can be modified by using a twin-ganged potentiometer to make a variable-frequency

peak-to-peak output of each circuit is roughly double the breakdown voltage of its diode regulator element.

In Fig. 5, the diodes start to conduct at 500 mV, so the circuit gives an output of about 1-volt peak-to-peak. In Fig. 6, the Zener diodes D1 and D2 are connected back-to-back, and may have values as high as 5 to 6 volts, giving a p-p (peak-to-peak) output of about 12 volts. Each circuit is set up by adjusting R3 for the maximum value (minimum distortion) at which oscillation can be maintained across the frequency band.

The frequency range of Wien-bridge oscillators can be altered by changing the C1 and C2 values; in-

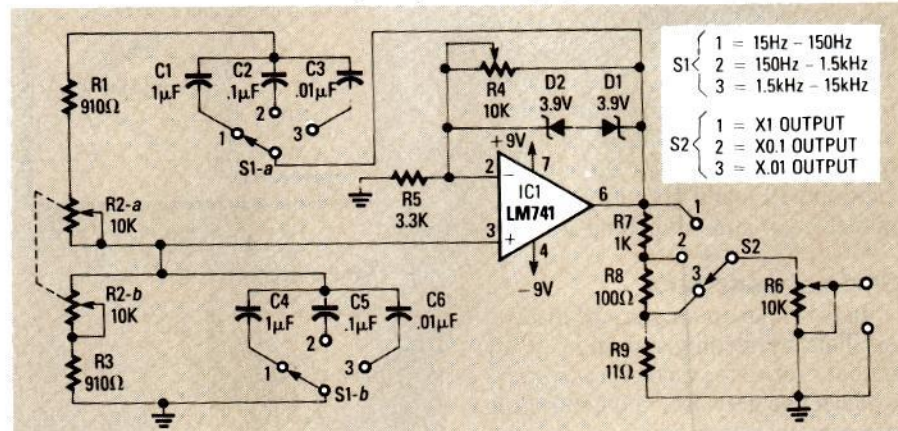

FIG. 7—THREE DECADE 15 Hz-15 kHz Wien-bridge oscillator.

oscillator over the range 150 Hz to 1.5 kHz. The sine-wave output amplitude can be made variable using R5.

A slightly annoying feature of thermistor-stabilized circuits is that, in variable-frequency applications, the output amplitude of the sine wave tends to "jitter" or "bounce" as the frequency control potentiometer is swept up and down its range.

Diode stabilization

The jitter problem of variable-frequency circuits can be minimized by using the circuits of Figs. 5 or 6, which rely on the onset of diode or Zener conduction for automatic gain control. In essence, R3 is for a circuit gain slightly greater than unity when the output is close to zero, causing the circuit to oscillate; as each half-cycle nears the desired peak value, one of the diodes starts to conduct, which reduces the circuit gain, automatically stabilizing the peak amplitude of the output signal. That "limiting" technique typically results in the generation of 1% to 2% distortion on the sine-wave output. The maximum

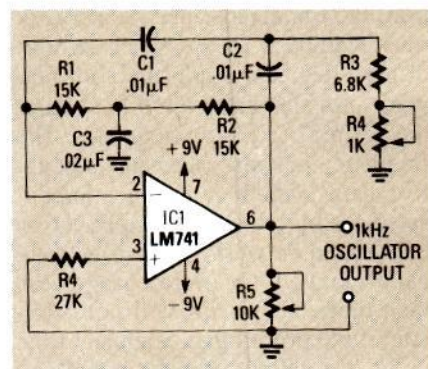

FIG. 8—1-kHz TWIN-T oscillator.

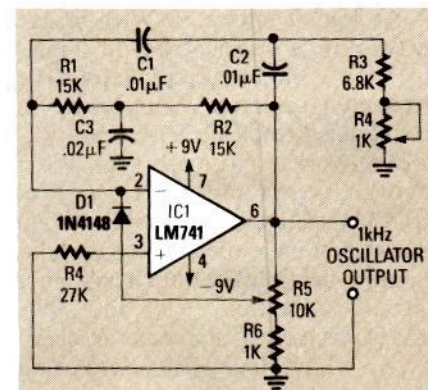

FIG. 9—DIODE-REGULATED 1-kHz twin-T oscillator.

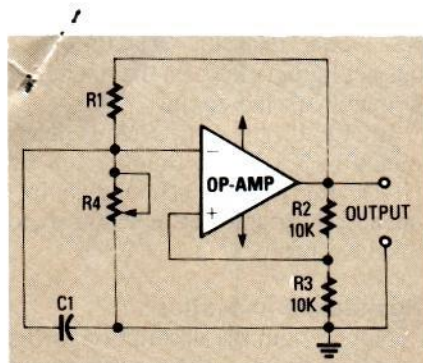

FIG. 10—RELAXATION SQUARE-WAVE oscillator.

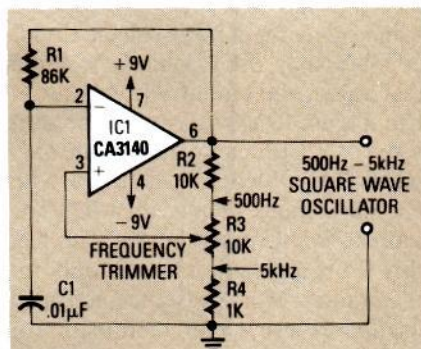

FIG. 11—500 Hz-5 kHz SQUARE-WAVE oscillator.

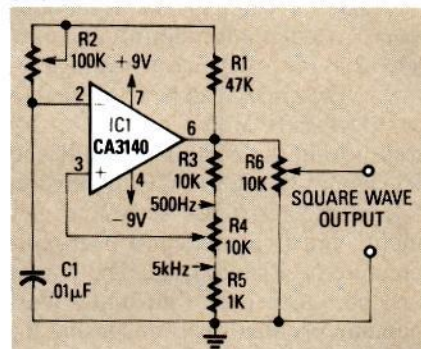

FIG. 12—IMPROVED 500 Hz-5 kHz square-wave oscillator.

creasing $C1$ and $C2$ by a decade reduces the output frequency by a decade. Figure 7 shows the circuit of a variable-frequency Wien oscillator that covers the range 15 Hz to 15 kHz in three switched-decade ranges. The circuit uses Zener-diode amplitude regulation, and its output is adjustable by both switched and fully-variable attenuators. Notice that the maximum useful operating frequency is restricted by the slew-rate limitations of the op-amp. The limit is about 25 kHz using a LM741 op-amp, or about 70 kHz using a CA3140.

Twin-T oscillators

Another way of designing a sine-wave oscillator is to wire a twin-T network between the output and input of an inverting op-amp, as shown in Fig. 8. The twin-T network comprises

$R1$ - $R2$ - $R3$ - $R4$ and $C1$ - $C2$ - $C3$. In a "balanced" circuit, those components are in the ratios $R1 = R2 = 2(R3 + R4)$, and $C1 = C2 = C3/2$. When the network is perfectly balanced, it acts as a notch filter that gives zero output at a center frequency (f_0), a finite output at all other frequencies, and the phase of the output is 180° inverted. When the network is slightly unbalanced by ad-

operation due to the difficulties of varying three or four network components simultaneously.

Square-wave generator

An op-amp can be used to generate square-waves by using the relaxation oscillator configuration of Fig. 10. The circuit uses dual power supplies, and the op-amp output switches alternately between positive and negative

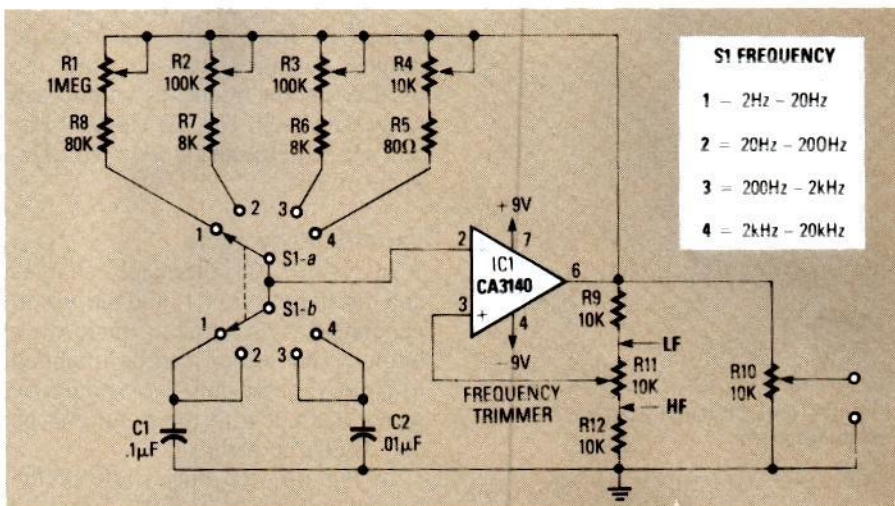

FIG. 13—FOUR DECADE 2 Hz-20 kHz SQUARE-WAVE generator.

justing $R4$, the network will give a minimal output at f_0 .

By critically adjusting $R4$ to slightly unbalance the network, the twin-T gives a 180° inverted phase shift with a small-signal f_0 . Because the inverting op-amp also causes a 180° input-to-output phase shift, there is zero overall phase inversion as seen at the inverting op-amp input, and the circuit oscillates at a center frequency of 1 kHz. In practice, $R4$ is adjusted so that oscillation is barely sustained, and under that condition the sine wave has less than 1% distortion.

Figure 9 shows an alternative method of amplitude control, which results in slightly less distortion. Here, $D1$ provides a feedback signal via potentiometer $R5$. That diode reduces the circuit gain when its forward voltage exceeds 500 mV. To set up the circuit, first set $R5$ for maximum resistance to ground, then adjust $R4$ so that oscillation is just sustained. Under those conditions, the output signal has an amplitude of about 500 mV p-p. Further $R5$ adjustment enables the output signal to be varied between 170 mV and 300-mV RMS.

Note that twin-T circuits make good fixed-frequency oscillators, but are *not* suitable for variable-frequency

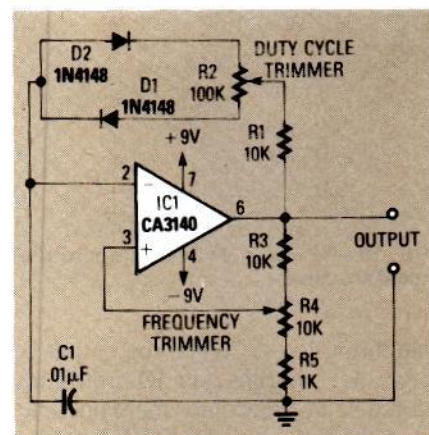

FIG. 14—SQUARE-WAVE GENERATOR with variable duty-cycle, and frequency.

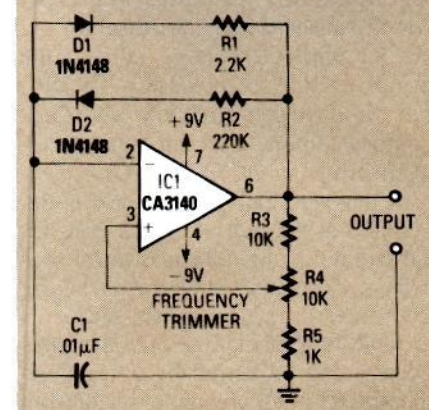

FIG. 15—VARIABLE FREQUENCY narrow-pulse generator.

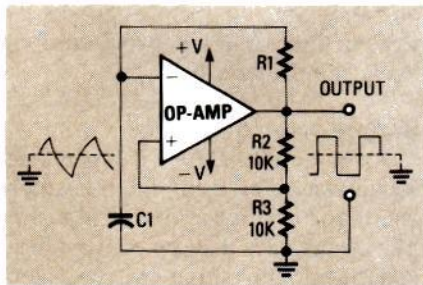

FIG. 16—RESISTANCE-ACTIVATED relaxation oscillator.

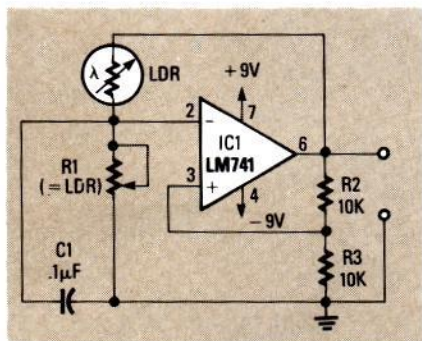

FIG. 17—PRECISION LIGHT-ACTIVATED oscillator/alarm.

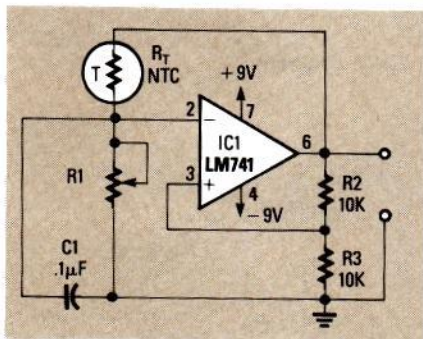

FIG. 18—PRECISION over-temperature oscillator/alarm

saturation levels. When the output is high, C1 charges via R1 until the stored voltage becomes more positive than the value set by R2-R3 at the non-inverting input. The output then regeneratively switches negative, which causes C1 to start discharging via R1 until C1 voltage falls to the negative value set by R2-R3. The output then regeneratively switches positive again, and the whole sequence repeats *ad infinitum*.

A symmetrical square wave is developed at the output, and a non-linear triangular waveform is developed across C1; those waveforms swing symmetrically on both sides of ground. Notice that the operating frequency can be varied by altering either the R1 or C1 values, or by altering the R2-R3 ratios, which makes that circuit quite versatile.

Figure 11 shows how to design a practical 500 Hz to 5-kHz square-wave generator, with frequency variations obtained by altering the attenuation ratio of R2-R3-R4. Figure 12 shows how to improve Fig. 11 by using R2 to preset the range of frequency control R4, and by using R6 as an output amplitude control.

Figure 13 shows how to design a general purpose square-wave generator that covers the 2 Hz to 20-kHz range in four switched-decade ranges. Potentiometers R1 to R4 are used to vary the frequency within each range: 2 Hz–20 Hz, 20 Hz–200 Hz, 200 Hz–2 kHz, and 2 kHz–20 kHz, respectively.

Variable duty-cycle

In Fig. 10, C1 alternately charges and discharges via R1, and the circuit generates a symmetrical square-wave output. That circuit can be modified to give a variable duty-cycle output by providing C1 with alternate charge and discharge paths.

In Fig. 14, the duty cycle of the output waveform is fully variable from 11:1 to 1:11 via R2, and the frequency is variable from 650 Hz to 6.5 kHz via R4. The circuit action is such that C1 alternately charges through R1-D1 and the bottom of R2, and discharges through R1-D2 and the top of

R2. Notice that any variation of R2 has negligible effect on the operating frequency of the circuit.

In Fig. 15, the duty cycle is determined by C1-D1-R1 (mark), and by C1-D2-R2 (space). The pulse frequency is variable between 300 Hz to 3 kHz via R4.

Resistance activation

Notice from the description of the oscillator in Fig. 10 that the output changes state at each half cycle when the C1 voltage reaches the threshold value set by the R2-R3 voltage divider. Obviously, if C1 is unable to attain that value, the circuit will not oscillate. Figure 16 shows a resistance activated oscillator that will oscillate *only* when R4, which is in parallel with C1, has a value greater than R1. The ratio of R2:R3 must be 1:1. The fact that R4 is a potentiometer is only for illustration. Most resistance-activated oscillators use either thermistors or LDR's, which simulate the potentiometer action.

Figure 17 is a precision "light-activated" oscillator (or alarm), and uses a LDR as the resistance activating element. The circuit can be converted to a "dark-activated" oscillator by transposing the position of LDR and R1. Figure 18 uses a NTC thermistor, R_T, as the resistance-activating element, and is a precision over-temperature oscillator/alarm. The circuit can be converted to an under-temperature oscillator by transposing R_T and R1.

The LDR or R_T can have any resistance in the range from 2000 ohms to 2 megohms at the required trigger level, and R1 must have the same value as the activating element at the desired trigger level; the C1 value can be altered to change the oscillation frequency.

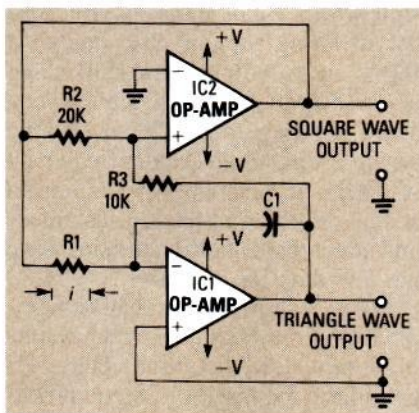

FIG. 19—BASIC FUNCTION GENERATOR for both triangular, and square waves.

Triangle/square generation

Figure 19 shows a function generator that simultaneously produces a

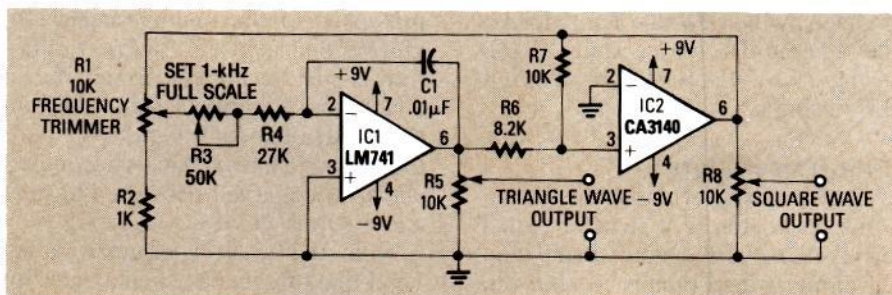

FIG. 20—100 Hz-1 kHz FUNCTION GENERATOR for both triangular, and square waves.