

TWO PREVIOUS ARTICLES (SEPTEMBER, page 58 and October page 69) explained the operation of the popular and versatile industry-standard 555 timer IC as a monostable and astable multivibrator. They gave examples of its use in accurate time delay or oscillator circuits.

This third article starts by discussing the 555 as the key component in a Schmitt trigger circuit. It goes on to explain the role of the 555 in various astable multivibrator or oscillator circuits with many practical applications. Those circuits include light- and dark- as well as hot- and cold-actuated alarms. Other circuits are a code practice oscillator, a door buzzer, a continuity tester, a signal generator, and a metronome. Various light-actuator and relay-driver circuits are included.

### Schmitt trigger

Figure 1 is the pinout and functional block diagram for the 555 timer IC. In previous articles it was pointed out that for a 555 in the time-delay operation mode, timing can be precisely controlled by one external resistor and one capacitor. For astable operation as an oscillator, the free-running frequency and duty cycle can be accurately controlled with two external resistors and a single capacitor.

It is worth recalling that the 555 can be triggered and reset on falling waveforms, and the output circuit can source or sink up to 200 milliamperes, or drive TTL circuits. The 555's features include normally on and normally off outputs.

Figure 2-a illustrates the 555 IC as the active component in a Schmitt trigger circuit. Notice that the 555's TRIGGER pin 2 and THRESHOLD pin 6 are connected to form an input terminal. External input signals are applied directly at that point. The OUTPUT pin 3 becomes the output terminal.

Internal comparators A and B (see Fig. 1) are biased with an on-chip voltage divider. That divider biases comparator A at

# 555 OSCILLATORS

*Put the 555 time to work as a Schmitt trigger or as the heart of light and temperature alarms and drivers, a metronome, and a continuity checker.*

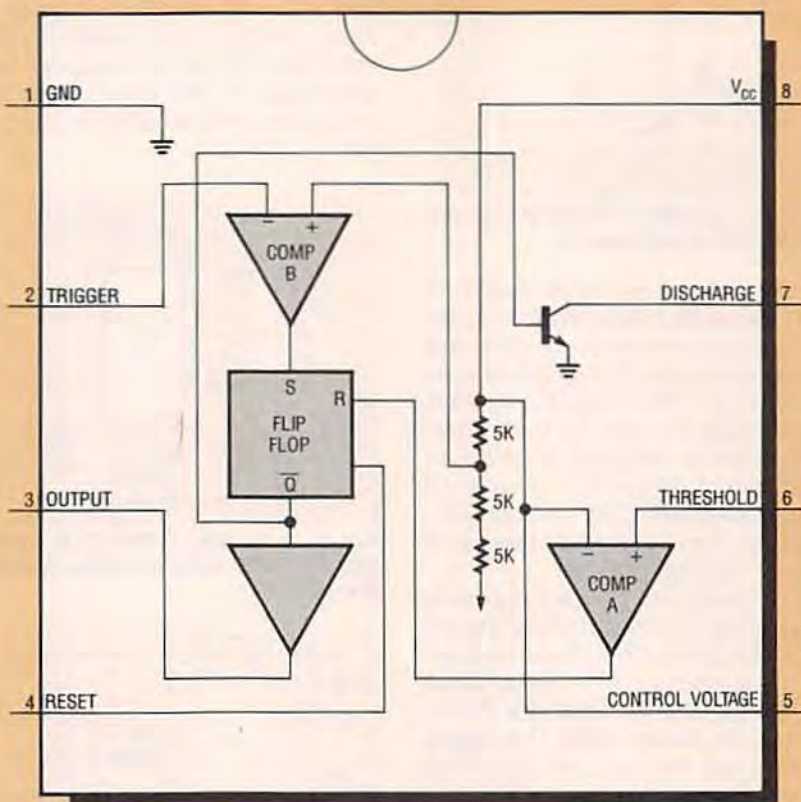

FIG. 1—PINOUT AND FUNCTIONAL BLOCK diagram of the 555 timer IC.

two-thirds of the supply voltage, and the non-inverting terminal of comparator B at one-third of the supply voltage. Comparator A drives the R input and comparator B drives the S input of the on-chip R-S flip-flop.

When the input voltage of the circuit in Fig. 2-a rises above two-thirds of the supply voltage, the 555 output switches to its low state. It remains there until the input voltage falls below one-third of the supply voltage.

Then the output switches high and remains high until the input rises above the two-thirds supply level again.

The difference between those two trigger levels is called the hysteresis value. It is one-third of the supply in Fig. 2-a. That large hysteresis makes the circuit useful in signal conditioning where noise and ripple must be rejected, as shown in Fig. 2-b.

Figure 3 shows how the cir-

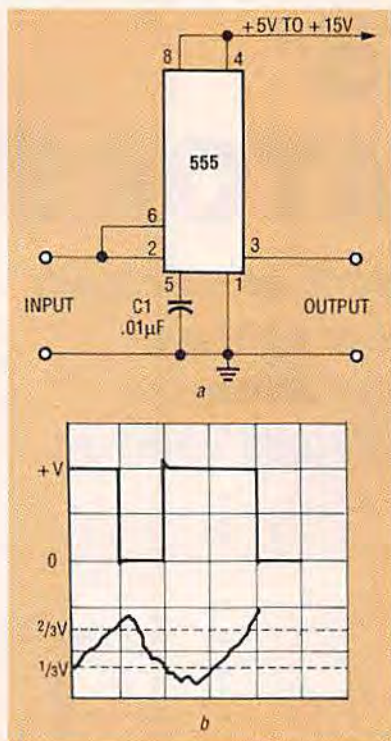

FIG. 2—A SCHMITT TRIGGER CIRCUIT formed with a 555 timer IC.

cuit in Fig. 2-a can be modified into a high-performance sine-to-square-wave converter useful at input frequencies up to about 150 kHz. The voltage divider formed by R1 and R2 biases the input terminal (pins 2 and 6) of the 555 at its quiescent value of one-half the supply voltage (i.e., midway between the upper and lower trigger values).

The sine-wave input signal is superimposed on this point with capacitor C1. Square-wave output signals are taken from pin 3 of the IC. Resistor R3 is wired in series with the input terminal to ensure that the sine-wave signal is not distorted when the 555 switches.

Figure 4 shows how the Schmitt trigger circuit can be made into a dark-activated relay actuator by wiring the light-dependent voltage divider consisting of potentiometer R1 and photocell R2 to the input terminal of the IC. The potentiometer and photocell resistance values are nearly equal at the middle of the light-activation range.

The inherently high input backlash or hysteresis of the Schmitt trigger limits the usefulness of this circuit to very specialized light-sensing ap-

plications. A more useful relay-driving, dark-activated switching circuit is shown in Fig. 5. It acts as a fast comparator rather than a true Schmitt trigger. The THRESHOLD pin 6 to internal comparator A of the 555 is tied permanently high by resistor R3, while the output of the light-sensing potentiometer R1 and photocell R2 voltage divider is applied to TRIGGER pin 2 of comparator B.

The photoresistive element for this circuit can be any cadmium-sulfide photocell whose resistance is between 470 ohms and 10 kilohms at the desired turn-on light level. The circuit in Fig. 5 can also function as a light- (rather than dark-) activated switch by exchanging the positions of the potentiometer and photocell, as shown in Fig. 6-a.

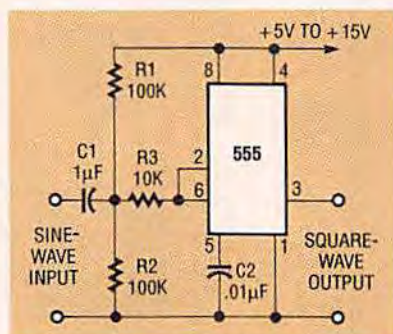

FIG. 3—A SCHMITT TRIGGER SINE- AND SQUARE- wave generator formed with a 555 IC.

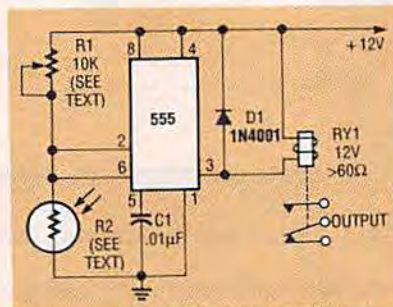

FIG. 4—DARK-ACTIVATED RELAY SWITCH BASED on the 555 has a lot of hysteresis.

The circuit can also function as a temperature-activated switch by substituting a thermistor with a negative temperature coefficient for the photocell, as shown in Figs. 6-b and 6-c. (A thermistor with a negative temperature coefficient decreases in resistance as temper-

ature increases.) The thermistor for this application must have a resistance value between 470 ohms and 10 kilohms at the desired turn-on temperature. Thermistors are typically packaged as radial-leaded disks, and their resistance values are specified at 25° C.

### Stable of oscillators

The 555 in the astable multi-vibrator or oscillator mode has three outstanding advantages over other kinds of oscillators:

- Excellent frequency stability with variations in supply voltage and temperature.
- Frequency variable over a wide range with a single potentiometer control.
- Low impedance output that can source or sink currents up to 200 milliamperes.

Figure 7 shows the 555 as the semiconductor IC in a Morse-code practice oscillator. The circuit is an oscillator with its frequency variable from 300 Hz to 3 kHz by adjusting tone control potentiometer R3. The sound volume of headphone Z1 can be varied with potentiometer R4, and the headphones can have any DC resistance from a few ohms up to a few megohms. The oscillator circuit draws no quiescent current until the normally-open Morse key connects the circuit to the 5- to 15-volt supply.

Figure 8 shows the 555 as the semiconductor device in a simple electronically actuated door buzzer. Pushbutton switch S1 connects the 555 to the 9-volt battery, and the output of the IC is coupled to speaker SPKR1 through capacitor C4. Capacitor C1 produces a low supply-line impedance, ensuring ade-

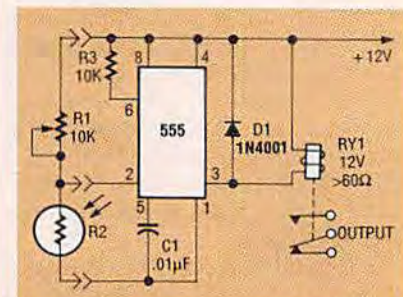

FIG. 5—MINIMUM-BACKLASH, DARK-ACTIVATED relay based on the 555.

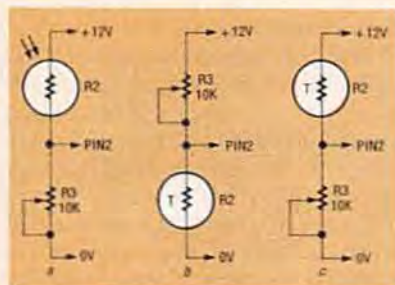

FIG. 6—ALTERNATIVE SENSOR CIRCUITS for Fig. 5 provide actuation by light (a), under-temperature (b), and over-temperature (c).

quate output drive current to the speaker when S1 is closed. The circuit generates a monotone buzzing sound set by potentiometer R2.

Figure 9 shows the 555 as the semiconductor component in a continuity tester that generates an audible tone only if the resistance between the test probes is less than a few ohms. The circuit's operation depends on an output tone that sounds only if the RESET (pin 4) is biased positive to about 600 millivolts or greater by sensitivity potentiometer R5. Pin 4 is normally pulled to ground by resistor R2, so no tone is heard.

For the buzzer in the circuit of Fig. 9 to sound, the two probe tips must touch, connecting R2 to the output of the reference generator formed by resistor R3 and Zener diode D1 through sensitivity potentiometer R5. Potentiometer R5 must be carefully adjusted so that a buzzing sound is barely audible. Consequently, if the resistance between the probe tips exceeds a few ohms when a continuity test is being made, the buzzing tone will not be heard. The circuit draws several milliamperes whenever S1 is closed, even if the probe tips are not touching.

Figure 10 shows the 555 functioning as a signal generator for testing both audio and radio-frequency circuits. The circuit oscillates at a frequency of a few hundred hertz when S1 is closed. Its square-wave output is very rich in harmonics, and those can be detected at frequencies up to tens of megahertz with a radio receiver. The signal level can be varied by adjusting potentiometer R3.

In Fig 11 the 555 is the active component of a metronome with a beat rate variable from 30 to 120 beats per minute. The beat rate can be set by adjusting potentiometer R3, and the beat level can be set by adjusting potentiometer R4. This circuit is a modified version of the stan-

When the output switches high, C1 charges rapidly through diode D1 and resistor R1 in series to generate a beat pulse only a few milliseconds long. When the output switches low again, C1 discharges through potentiometer R3 and resistor R2 in series to provide an off period of up to two seconds (30 beats per minute). The output pulses are fed to speaker SPKR1 through level-control potentiometer R4 and buffer transistor Q1.

### LED flashers and alarms.

Figures 12 to 14 show the 555 in LED flasher applications in which the LED's have equal on and off switching times. With the component values shown, each circuit flashes at a rate of about one flash per second.

The circuit in Fig 12 has a single-ended output. Either a single LED (or LED's in series) can be connected between the OUTPUT pin3 and GROUND pin 1 of the 555, and all LED's turn on and off together. Resistor R3 sets the on current of the LED's.

The circuit in Fig. 13 is similar to that of Fig. 12, but it has a double-ended output connection. The LED's above pin 3 are

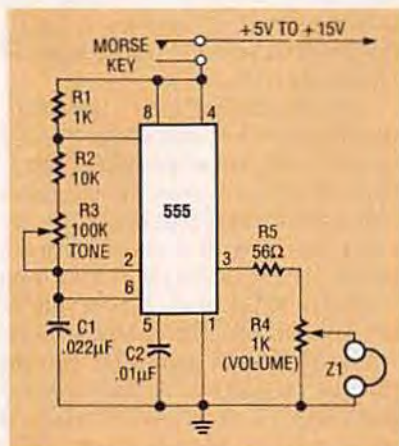

FIG. 7—CODE-PRACTICE OSCILLATOR with variable tone and volume.

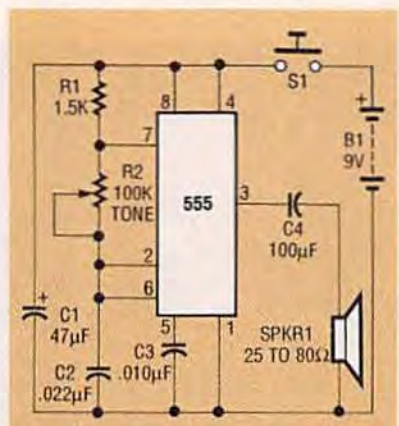

FIG. 8—ELECTRONIC DOOR BUZZER based on the 555.

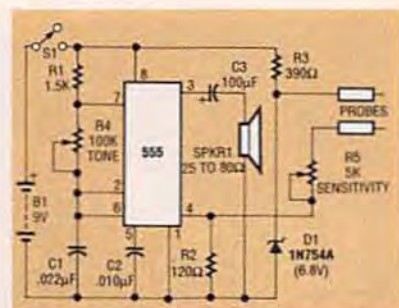

FIG. 9—CONTINUITY TESTER based on the 555.

dard astable multivibrator in which the main timing network is driven from OUTPUT pin 3 of the IC.

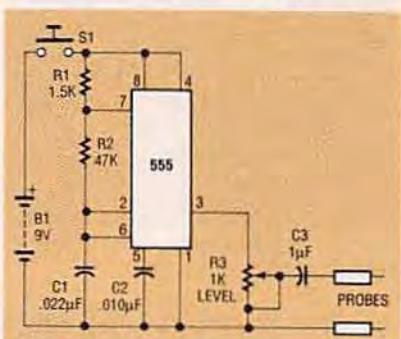

FIG. 10—SIGNAL GENERATOR based on the 555

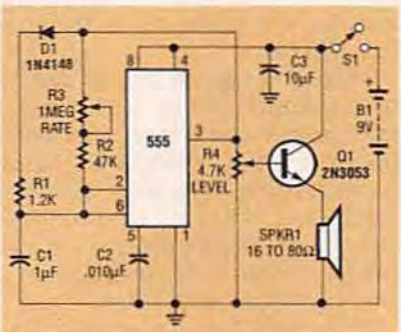

FIG. 11—METRONOME CIRCUIT based on the 555.

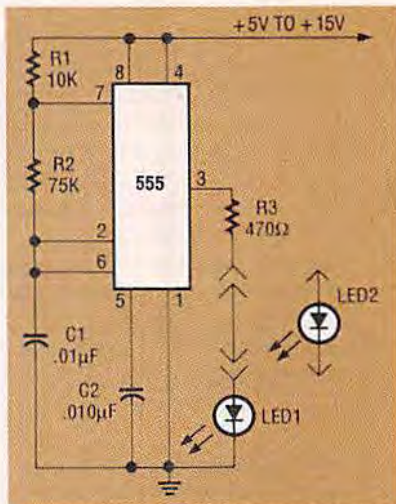

FIG. 12—LED FLASHER WITH SINGLE-ENDED output.

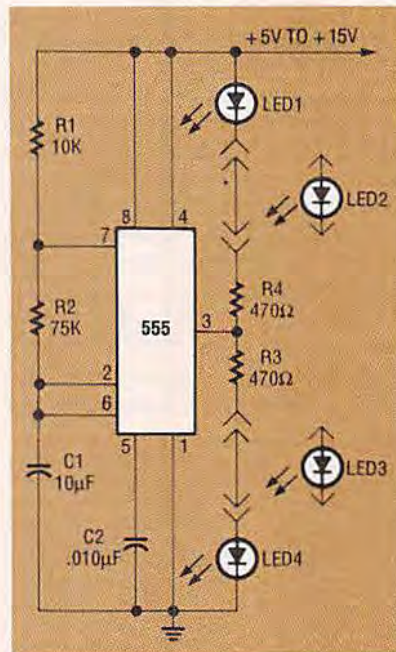

FIG. 13—LED FLASHER WITH DOUBLE-ENDED output.

on when the LED's below pin 3 are off, and vice versa. Resistor R3 sets the *on* currents of the lower LED's, and resistor R4 sets the *on* currents of the upper LED's.

Figure 14 shows how to modify the circuit in Fig. 12 for automatic dark-actuation. Resistors R3 and R4, photocell R1, and potentiometer R2 form a light-sensitive Wheatstone bridge that triggers the 555 through bridge balance-detector Q1 and the RESET pin 4 of the IC.

The oscillator is normally disabled by resistor R6, which pulls RESET pin 4 close to zero

volts. The circuit oscillates only when pin 4 is pulled to a positive voltage greater than 600 millivolts. That can be achieved only by turning on Q1.

As one arm of the Wheatstone bridge, resistors R4 and R5 apply a fixed half-supply voltage to the emitter of Q1. The photocell and potentiometer form the other arm that applies a light-dependent voltage to the base of transistor Q1.

Under bright light, the photocell offers low resistance. As a result, the base-emitter junction of Q1 is reverse biased, and the circuit does not oscillate. By contrast, under dark conditions, the photocell resistance is high, so Q1 and the oscillator are biased on. Normally, potentiometer R2 is adjusted so the 555 is triggered at the desired dark level. The photocell should have a resistance between 470 ohms and 10 kilohms under

this condition.

The precision gating method described can trigger a variety of 555 oscillator circuits to form useful audible alarms and relay drivers. By interchanging the photocell with the potentiometer, or replacing the photocell with a thermistor having a negative temperature coefficient, those circuits can be triggered by increases or decreases beyond preset values in either light or temperature. Figures 15 to 17 illustrate practical examples of such circuits.

Figure 15 shows an automatic heat- or light-actuated relay driver. The circuit works with any 12-volt relay having a coil resistance greater than about 60 ohms. When actuated, the circuit triggers the relay RY1 on and off about once per second.

A heat- or light-actuated monotone alarm is shown in Fig. 16. When triggered, this circuit

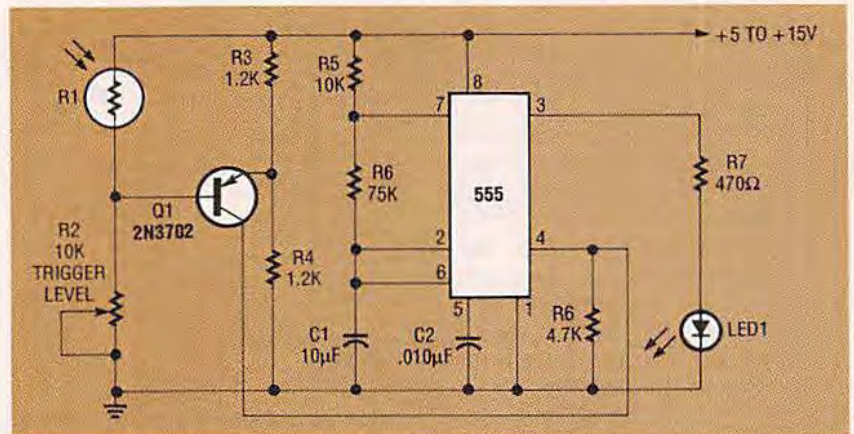

FIG. 14—AUTOMATIC (DARK-ACTUATED) LED FLASHER.

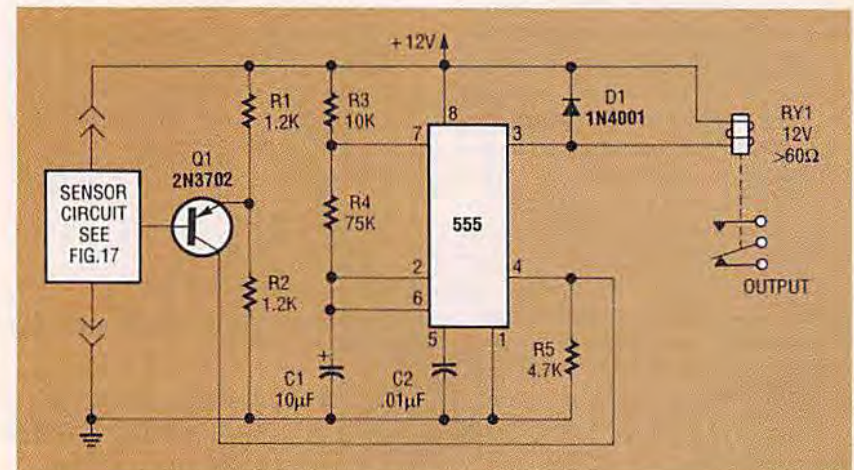

FIG. 15—HEAT- OR LIGHT-ACTUATED relay pulser

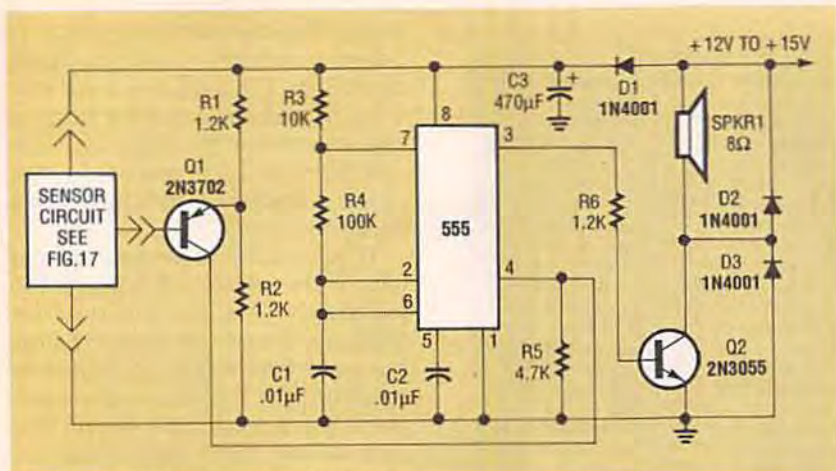

FIG. 16—HEAT- OR LIGHT-ACTUATED medium-power 800-Hz alarm.

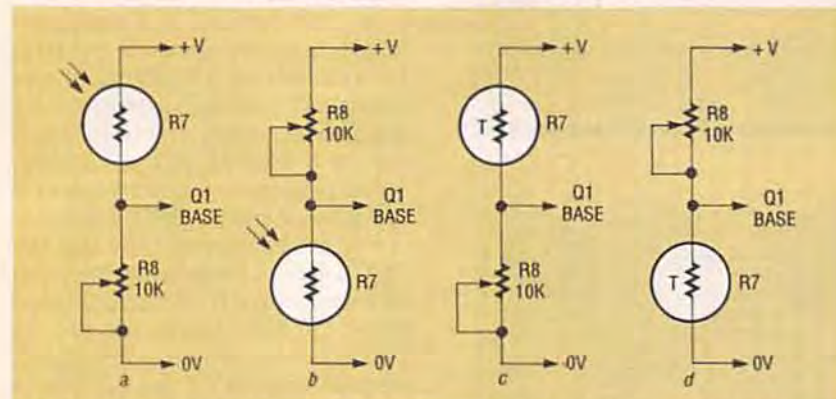

FIG. 17—ALTERNATIVE SENSOR CIRCUITS for Figs. 14 or 15 for actuation by darkness (a), light (b), under-temperature (c), or over-temperature (d).

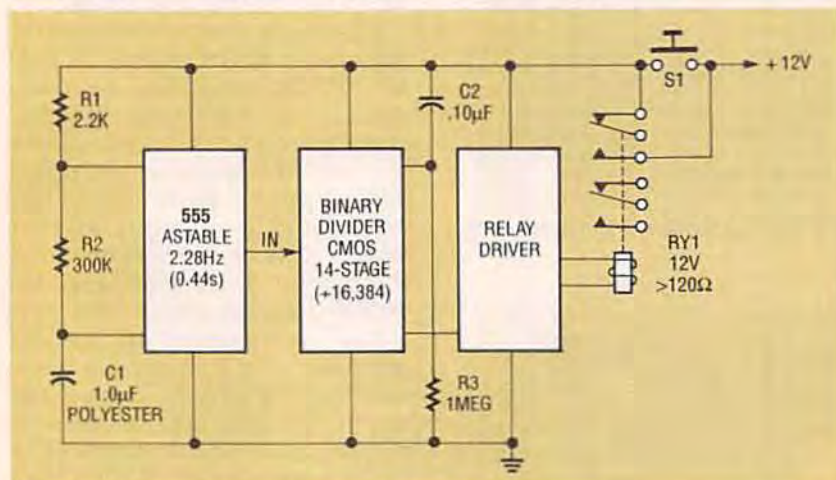

FIG. 18—A 60-MINUTE TIMER based on the 555.

generates a buzzing sound at about 800 Hz. Several watts of power are drawn from speaker SPKR1 through buffer transistor Q2. The resulting high-speaker output current could transfer ripple voltage to the power supply so diode D1 and capacitor C3 protect the circuit from that interference. Diodes D2 and D3 clamp the inductive

switching spikes of the speaker, protecting Q2 against damage. Alternative sensor circuits that can automatically activate the circuits of either Figs. 15 or 16 are shown in Fig. 17. If light actuation is desired, the sensor should be a cadmium-sulfide photocell. If the circuit is to be triggered when light level falls to a preset value (dark actuation),

the circuit of Fig 17-a should be used. If the circuit is to be triggered when the light intensity rises to a preset value (light actuation), the circuit of Fig 17-b should be used.

If you want temperature actuation, use a thermistor with a negative temperature coefficient as the sensor. For under-temperature operation, use the circuit of Fig. 17-c; for over-temperature operation, use the circuit of Fig. 17-d. Regardless of the kind of operation desired, the sensor element must have a resistance value between 470 ohms and 10 kilohms at the desired trigger level.

### Long-period timers

A 555 can function as a superb manually-triggered relay-driving timer when it is connected in the monostable or pulse-generator mode. In practical applications, such a circuit will not generate accurate timing signals of more than a few minutes because they require an electrolytic capacitor with a high capacitance value. Electrolytic capacitors typically have wide tolerance values (-50 to +100%) and large and unpredictable leakage currents.

If the 555 is to be the active component in long-period timers, the external circuitry must include a capacitor other than an electrolytic. Figure 18 shows, as a block diagram, the principles behind a design for a 60-minute relay-driving timer. In this case, the 555 is organized in the astable mode. It has its output connected to the relay driver through a 14-stage binary divider IC. That configuration gives an overall division ratio of 16,384.

If the output of the 555 is set to zero at the start of an input count, the output will switch high upon receiving the 8192nd input pulse. The circuit will remain high until the 16,382nd pulse arrives. At that time, the output will switch low again, completing the normal operating sequence.

In Fig. 18, the timing sequence is initiated by closing S1, which connects the supply to the circuit, simultaneously

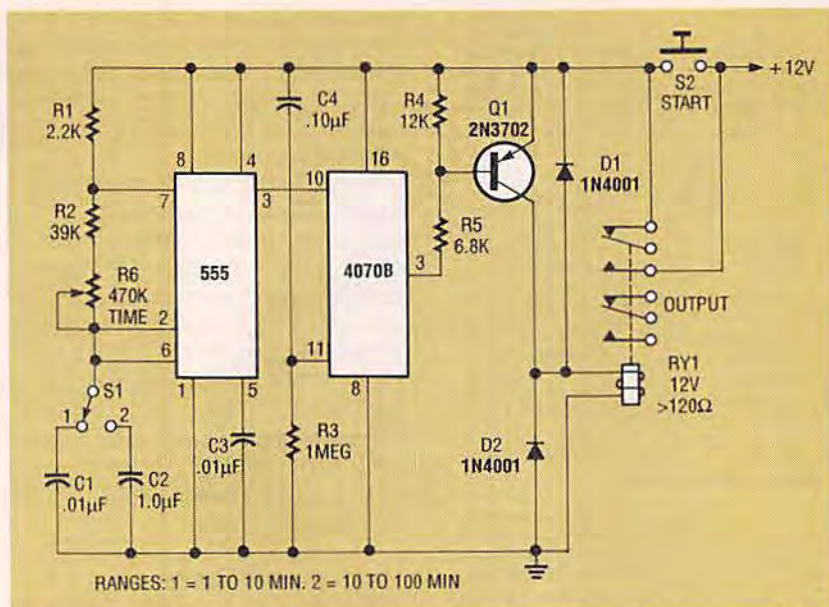

FIG. 19—TWO-RANGE RELAY OUTPUT TIMER providing 1 to 10 minute- and 10- to 100-minute intervals.

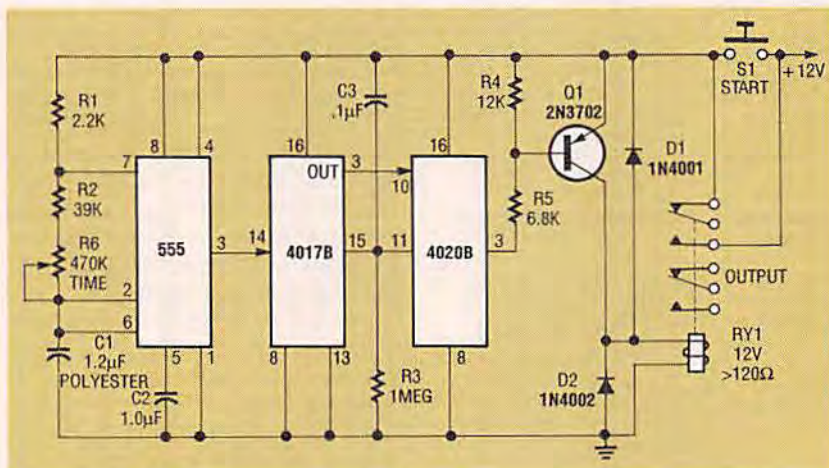

FIG. 20—EXTRA-LONG PERIOD RELAY OUTPUT TIMER provides 100-minute to 20-hour intervals.

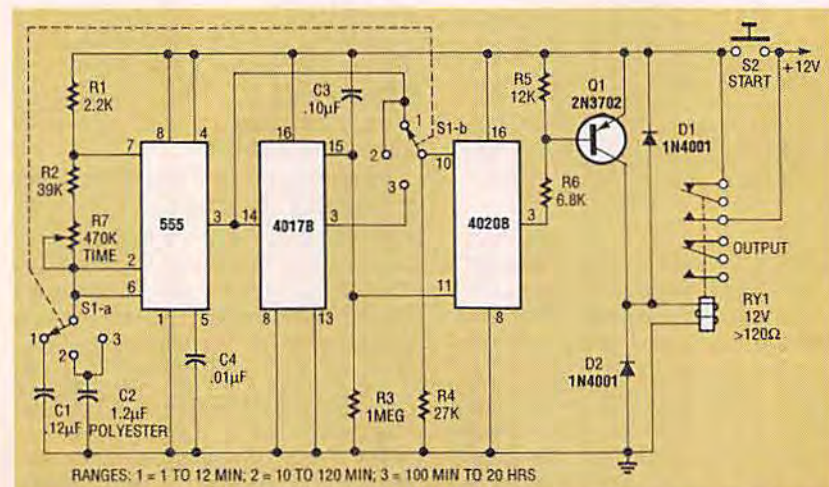

FIG. 21—WIDE-RANGE TIMER COVERING 1-minute to 20-hour intervals in three decade ranges.

triggering the oscillator and setting the counter to zero through capacitor C2 and resistor R3. That drives the counter output low and turns the relay on. The contacts of RY1 maintain the power supply connection once S1 is released.

This condition is maintained until the 8192nd oscillator pulse arrives at the input of the counter. Then the counter output switches high and turns the relay off. As the relay turns off, the contacts of RY1 open, disconnecting the supply from the circuit and completing the operating cycle.

In this circuit, the oscillator must operate with a cycling period that is 1/8192nd of the required timing period (0.44 second for this circuit). That can be achieved with a 1 microfarad polyester capacitor and a resistor of about 300 kilohms.

Figure 19 shows how the design in Fig. 18 is implemented to form a practical relay-output timer circuit useful for one to 100 minutes in two overlapping decade ranges. That circuit is powered from a 12-volt supply. The relay must have a coil resistance of 120 ohms or more.

Figure 20 illustrates how the time delay of the circuit in Fig. 19 can be extended by connecting an additional divider stage between the output of the 555 and the input of the relay-driving output state. In this circuit a divide-by-ten 4017B CMOS IC is connected between the output of the 555 and the 4020B 14-stage binary counter.

The arrangement in Fig. 20 gives an effective overall division ratio of 81,920, thus making delays from 100 minutes to 20 hours available from this single-range timer. Notice that both of the divider IC's are automatically reset by the series combination of capacitor C3 and resistor R3 when switch S1 is closed.

Figure 21 shows to modify the circuit in Fig. 20 to make a wide-range general-purpose timer that covers one minute to 20 hours in three decade-based ranges. The divide-by-ten stage is active only when switch S1-a is at position 3.