

**WARNING!!** This article deals with and involves subject matter and the use of materials and substances that may be hazardous to health and life. Do not attempt to implement or use the information contained herein unless you are experienced and skilled with respect to such subject matter, materials and substances. Neither the publisher nor the author make any representations as to the accuracy of the information contained herein and disclaim any liability for damages or injuries, whether caused by or resulting from inaccuracies of the information, misinterpretations of the directions, misapplication of the information or otherwise.

# BUILD A SEMICONDUCTOR LASER SYSTEM



***Visible-light laser diodes are here! In the first article of its kind, we'll show you how to build a handheld, rechargeable, semiconductor laser system.***

ROBERT IANNINI

THE INTRODUCTION OF LASERS IN 1963 has brought about many changes in our lives, from the supermarket check-out counter to "Star Wars" weapon technology. Very few scientific developments have had as much of an impact on both the technological and everyday world.

"Laser" is an acronym for "light amplification by stimulated emission of radiation." Lasers are used in many applications, including gun sites, pointers, printers, construction and surveying aids, compact-disc players, bar-code readers, light shows, and several others. The helium-neon gas laser is one of the most familiar types, with its bright red directional beam. It's been a workhorse for years, despite its fragile glass laser tube and its requirements for costly high-voltage power supplies. But laser diodes promise to open a whole new world of applications. To demonstrate how they can be used, we've developed a handheld battery-powered laser that runs on four rechargeable batteries. The batteries are inductively charged using a special charger. The unit is shown in Fig. 1. How is that possible?

The recently developed TOLD-9200-series of laser diodes from Toshiba emit coherent laser light in the visible spectrum, and don't require a high-voltage power supply. Because they're small, low-cost, and fairly rugged, laser diodes are well-suited for many applications.

Before proceeding further, let's review some basic laser theory, but first we must talk about regular light for a minute. When you turn on a light bulb, light energy is emitted in what is referred to as "spontaneous" form. It is an integration of many individual atomic energy level changes, each producing its own little "packet" or photon of light energy, with each photon having a particular phase.

In the case of a light bulb, electrical energy "pumps" the filament electrons to higher-than-normal atomic energy levels (see Fig. 2). Photons are emitted when the electrons return to their initial states and give up that energy in the form of light. The frequency of the light is dependent on the

difference between the previously excited and normal energy level states; the larger the difference in energy levels, the lower the wavelength of light. The light produced by the process of spontaneous emission is incoherent or random (see Fig. 3).

Unlike spontaneous emission, laser light is highly directional. The radiant energy is released in-step, or in synchronism, resulting in coherent reinforced light where all of the waves are in phase. In other words, all of the rays are parallel and at the same wavelength. To achieve that requires that the number of excited atoms in the higher energy state exceeds that of the initial or rest state. That condition, referred to as "population inversion," normally doesn't occur in nature and must be "forced" or pumped.

Given a population inversion, each energized atom is then "stimulated" to return to its lower energy state by the emission energy, or incident light of an adjacent atom (see Fig. 4). The result is coherent light waves as shown in Fig. 5. An optical cavity with mirrored ends is usually necessary to provide the right amount of stimulated energy for laser light. As shown in Fig. 6, the light is reflected back and forth within its confines until it is a powerful beam that is allowed to exit the cavity as useful laser light energy.

A laser diode is similar to an ordinary light-emitting diode (LED) in that both are composed of a semiconductor PN junction (see Fig. 7). An electrical potential causes a flow of holes and electrons that, upon recombination, emit light. The LED produces spontaneous light, while the laser emits light by stimulated emission. The laser diode also contains two reflecting mirrors that form what's called a Fabry-Perot cavity, and permit the emitted light to be highly directional, an important laser property.

In spite of a laser diode's apparent physical ruggedness, it is very sensitive to temperature changes, electrical transients, and operating-current parameters. It is totally unforgiving of errors, so our circuitry and construction techniques must take that into consideration.

## Safety first

Before proceeding, you should be aware of the potential hazards associated with lasers. Laser diodes can produce a continuous power in excess of 3 milliwatts. **That energy, when collimated, or viewed near-field, can cause retinal damage, so never look directly into the laser beam or through any lenses when the system is activated.** The laser that we are building is a Class IIIa device, and must be in compliance with U.S. safety standards for laser products (21 CFR 1040.10 and 1040.11).

Our device must bear a label like the one shown in Fig. 8. It must also have a label certifying that it conforms to classification specifications. At the output it must have the following label: **"Avoid Exposure, Visible Laser Radiation is Emitted From This Aperture."** Safety glasses should be worn when working with lasing devices of this power. Laser Peripherals, Hingham, MA is a good source; their model #DO-40 is suggested.

To prevent damage to the laser diodes, be sure not to exceed maximum ratings, even momentarily; or you could destroy the diode or cause it to require more current to produce its rated output (which will quickly lead to failure). Transients or spikes from switching both on and off can also destroy the device. Heat-sinking is required; the amount will be used intermittently or continuously. Keep in mind that a temperature rise reduces the output for a given current, and merely supplying more current will lead to a thermal problem.

Be aware of electrostatic discharge when handling laser diodes. Normally, assembly requires grounded tools, wrist straps, floor mats, etc. However, the hobbyist can either work on a hot humid day or use a vaporizer or humidifier to maintain a degree of moisture in the air—that will reduce the static charge.

Do not operate the unit near high-frequency or high-power pulse circuitry, an RF field, a Tesla coil, plasma, magnetic discharge, etc. Never stress the diode leads or distort the hermetically sealed case. The device

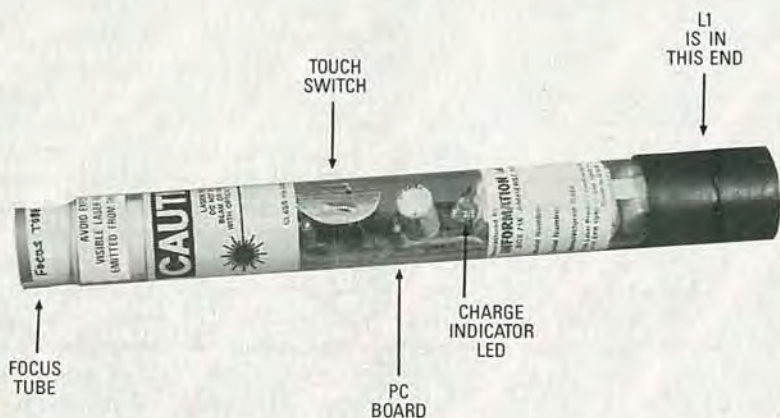

FIG. 1—OUR HAND-HELD LASER is powered from four rechargeable Ni-Cd batteries, which are inductively charged.

should fit snugly into the heat sink cavity with minimal force. Never touch the window because scratches and contaminants will distort and decrease the optical output. Use a cotton swab and ethyl alcohol to clean the window.

### Circuitry

A laser diode operates like an ordinary forward-biased diode and shows the operating curve in Fig. 9. The vertical axis corresponds to optical output while the horizontal axis is the forward diode current.  $I_{OP}$  is the operating current, which determines the optical output. Lasing starts at the threshold value ( $I_{TH}$ ). The maximum rated input current must never be exceeded. However, anything below  $I_{TH}$  will produce the effects of a regular LED. The curve shows a very steep slope where laser operation takes place, and the input-current "window" on the horizontal axis is very narrow; consequently the driver circuit must operate within those limits or you'll end up with one of the worlds most expensive medium-powered LED's.

The schematic of the hand-held laser is shown in Fig. 10. The Toshiba 9200 laser diode (D3) is actually an assembly that contains a laser-emitting section (LD) and a photodiode section (PD). The photodiode allows the circuit to monitor the laser diode's output and to produce the feedback necessary to control the circuit and protect the diode from voltage transients.

The laser diode is connected in series with current-limiting resistor R4 and the collector of Q4. The current through Q4 is con-

trolled by Q3. Zener diode D2 maintains the voltage across Q3, and R3 limits the Zener current. The collector current of Q3, which is also the base current of Q4, is controlled by its base which is connected across R5 and R6. Current from the photodiode develops a voltage across those resistors that is proportional to the optical output energy. That constitutes the feedback required for output stabilization. Increased output causes Q3 to conduct less base current to Q4, resulting in less laser diode current. Potentiometer R6 presets the value of quiescent current. Capacitor C5 limits transients at the base of Q4 while C4 limits them from the  $V_{CC}$  line.

The system turns on when Q2 is conducting and close to saturation. Touch-switch S1's electrodes consist of small pieces of metallic tape that, when bridged by finger contact, cause a small amount of base current to flow into Q1. The collector current of Q1 flows into the base of Q2, causing it to saturate and supply current to the laser diode. Base current to Q1 is limited by R2, while R1 and C2 reduce the circuit's sensitivity to stray AC or static fields that could cause premature turn-on.

The laser is powered by four rechargeable Ni-Cd batteries. They are charged by induction coupling to the charging module. The batteries are connected in series with rectifier diode D1, LED1, and the pickup coil, L1. High-frequency energy from the charger is coupled into the coil, and is rectified and filtered by C1. When the batteries are being charged LED1 turns on.

The charger schematic is shown Fig. 11, and a photograph of a prototype unit is shown in Fig. 12. It uses a 120-to-12 volt AC step-down transformer, T1, whose output is rectified by diodes D4-D7; capacitor C6 removes any ripples. Switch S2

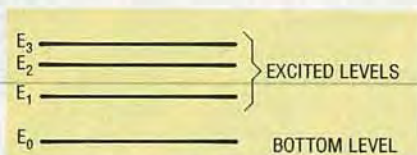

FIG. 2—LIGHT IS THE RESULT of radiation produced within an individual atom by an electron being "pumped" to a higher than normal energy level by an external energy source.

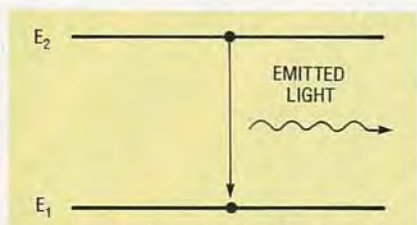

FIG. 3—A LIGHT BULB EMITS "spontaneous" light, which does not allow the energy packets to reinforce one another in phase or position.

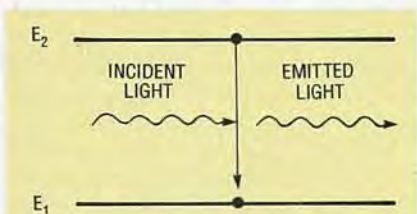

FIG. 4—WHEN MORE EXCITED ATOMS exist in the higher energy state than in the initial or rest state, each energized atom is "stimulated" to return to its lower energy state by the emission energy, or incident light of an adjacent atom.

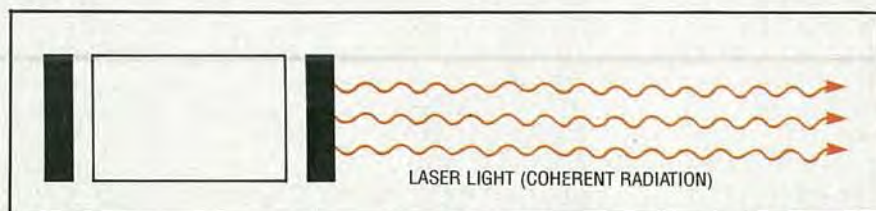

FIG. 5—A LASER BEAM IS THE RESULT of an "in lock step" train of coherent light waves.

supplies power to the circuit, and LED2 indicates when the power is on. The ground lead of PL1 is connected directly to the metal chassis of the charger.

The rectified 12–14 volts DC energizes a simple oscillator circuit consisting of Q5 in series with L2. That winding couples energy into the pick-up coil (L1) of the laser section for battery charging. To charge the batteries, the pickup coil physically slides over the coil assembly of the charger module. No electrical connections are necessary to provide the charging current.

Coil L3 (which is wound on the same ferrite core as is L2), and resistor R9 provide the necessary

### PARTS LIST FOR THE LASER

All resistors are ¼-watt, 5%, unless otherwise noted.

R1—5.6 megohms  
R2, R5—1000 ohms  
R3—470 ohms  
R4—15 ohms, ½-watt  
R4-a—100 ohms (optional, see text)  
R6—5000 ohms, trimmer potentiometer

#### Capacitors

C1—100 µF, 16 volts, electrolytic  
C2—0.1 µF, 16 volts, ceramic disc  
C3—0.01 µF, 16 volts, ceramic disc  
C4—1 µF, 16 volts, electrolytic  
C5—10 µF, 16 volts, electrolytic

#### Semiconductors

D1—1N4001 diode  
D2—1N5221 Zener diode (2.4 volts)  
D3—TOLD 9200 laser diode (Toshiba)  
LED1—yellow light-emitting diode  
LED3—red light-emitting diode (for the simulated laser diode)  
Q1, Q3—PN2907 NPN transistor  
Q2, Q4—PN2222 NPN transistor  
Q5—L14G3 or ECG3036 phototransistor (for the simulated laser diode)

#### Other components

B1–B4—1.25-volt Ni-Cd cell, VARTA 100 R.S.  
L1—pickup coil, 10 turns #18 wire, ½-inch diameter  
S1—2 pieces of adhesive-backed metal tape (see text)

**Miscellaneous:** PC board or perforated construction board, small transistor socket (for laser diode), special aluminum heatsink and diode retainer with hardware, #24 vinyl wire, #20 vinyl wire, 7/4-inch long by 1-inch diameter by 1/16-inch wall thickness (transparent or colored), 1/16 plastic rear cap, 1/8-inch by 7/8-inch focus tube, 1×6 mm short focal length lens, 1-inch plastic caps, 7/8-inch diameter shoulder washer (to mount lens on), warning labels, etc.

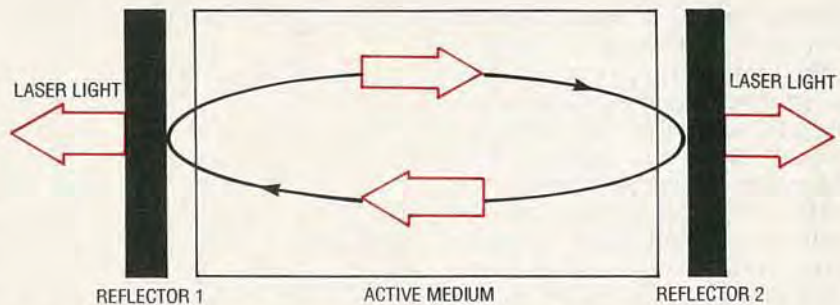

FIG. 6—AN OPTICAL CAVITY having mirrored ends provides the right amount of stimulated energy for laser light. Light is reflected back and forth within its confines until it is a powerful beam that is allowed to exit the cavity as useful laser radiation.

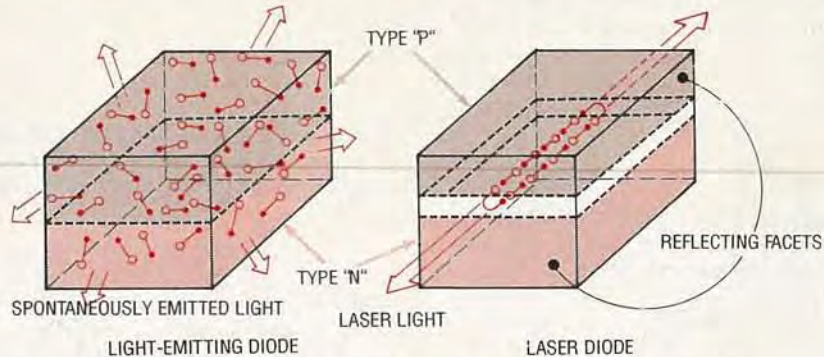

FIG. 7—A LASER DIODE IS SIMILAR to an ordinary LED, except that the LED produces spontaneous light, while the laser emits light by stimulated emission where the wavelengths and temporal relation are coherent. A laser diode also contains two reflecting mirrors that form a cavity and permit the emitted light to be highly directional.



FIG. 8—ANY LASER DEVICE must contain warning labels according to the specific type of device. Our hand-held laser must display this warning, in addition to a label stating that it conforms to specifications and a warning at the laser aperture.

feedback to sustain oscillation. Resistor R8 initiates the action by turning Q5 on. A resonating capacitor (C7) is connected across L2 to adjust the frequency to approximately 250 kHz.

#### Construction

All of the parts are available from the source mentioned in the parts list. A foil pattern has been provided if you wish to etch your own board for the laser unit, and a parts-placement diagram is

shown in Fig. 13.

If you wish, you can certainly install the circuit in any kind of housing that you like—you don't have to follow our unit exactly. Just make sure you follow the circuitry and the precautions concerning the laser diode.

The specifications for L1 are described in the parts list. Position it as shown in the handle of the laser so that it can slide over the charging coil (L2). DO NOT install the laser diode in the circuit at this time; install only its socket. The circuit must be checked and calibrated beforehand. Don't forget to build the "simulated laser diode" shown in Fig. 10. It is used later on for testing and calibrating the laser system, without the fear of damaging the actual laser diode.

A cylindrical plastic enclosure houses the board, the batteries, and the optics. After the board is finished and checked out, it slides inside the plastic tube and the leads for S1 (the touch switch) are brought outside through two small holes. (Wait until we check out the board before installing it in the tube.) Two

pieces of metal tape are used for the contacts. The lens is secured at the end of another tube using an appropriately sized washer. The lens assembly then slides in and out of the main tube, allowing you to focus the beam.

The charger circuit can be built on a small piece of perforated construction board and wired according to the schematic in Fig. 11. In the prototype, Q6 is heatsinked by attaching it to the surface of the metal cabinet. It must be insulated, so use a nylon screw and a mica washer to mount it (or use a separate heat-sink). Coils L2 and L3 are wound on a ferrite core (see parts list), then wrapped with tape. The as-

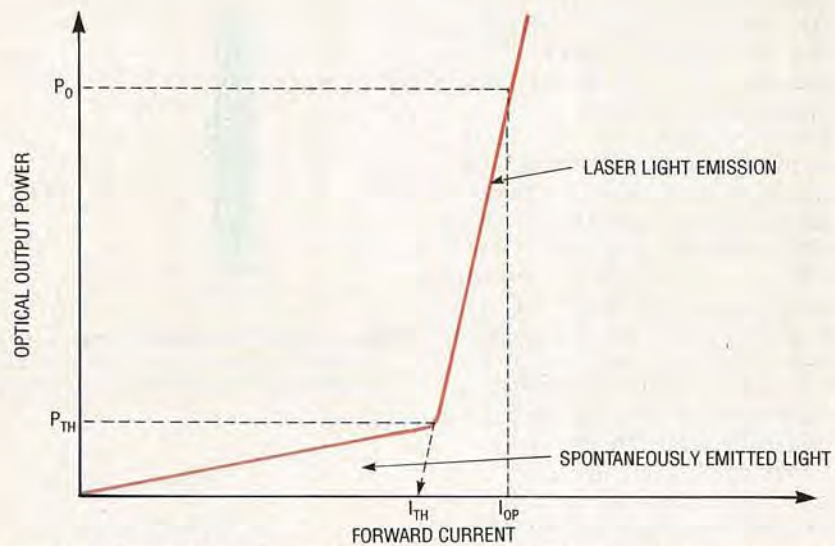

**FIG. 9—A LASER DIODE OPERATES** similarly to a forward-biased diode. The vertical axis corresponds to optical output while the horizontal axis is the forward diode current.  $I_{OP}$  is the operating current, and anything below  $I_{TH}$  will produce the effects of an LED.

#### PARTS LIST FOR THE CHARGER

All resistors are 1/4-watt, 5%, unless otherwise noted.

R7—470 ohms  
R8—22,000 ohms  
R9—10,000 ohms

#### Capacitors

C6—1000  $\mu$ F, 16 volts, electrolytic  
C7—0.047  $\mu$ F, 50 volts, Mylar

#### Semiconductors

D4—D7—1N4001 diode  
LED2—green light-emitting diode  
Q6—D40D5 or NTE210 NPN power transistor

#### Other components

L2, L3—coils wound on ferrite core (core is 1-inch in length, 1/4-inch diameter) L2 is 10 turns #24 wire, L3 is 10 turns #30 wire.

T1—120/12-volt AC step-down transformer, 100 mA

S2—SPST switch

PL1—3-wire line cord

**Miscellaneous:** perforated construction board, 6-32  $\times$  1/2-inch nylon screw and nut with mica washer (to mount Q6 to case), 2 1/2-inch plastic tube to fit over laser tube, metal cabinet (or use separate heatsink for Q6), line cord bushing, LED mounting bushing, double-sided tape, hardware, wire nuts, #24 vinyl wire, epoxy, etc.

sembly is then centered in the charger tube and secured with epoxy filler (see Fig. 12).

Figure 14 shows how the laser section and the charger go together. If you don't follow the prototype exactly, simply follow Fig. 14 as a rough layout.

#### Checkout

First make sure you do not have the laser diode in the circuit at this time. Plug the charger

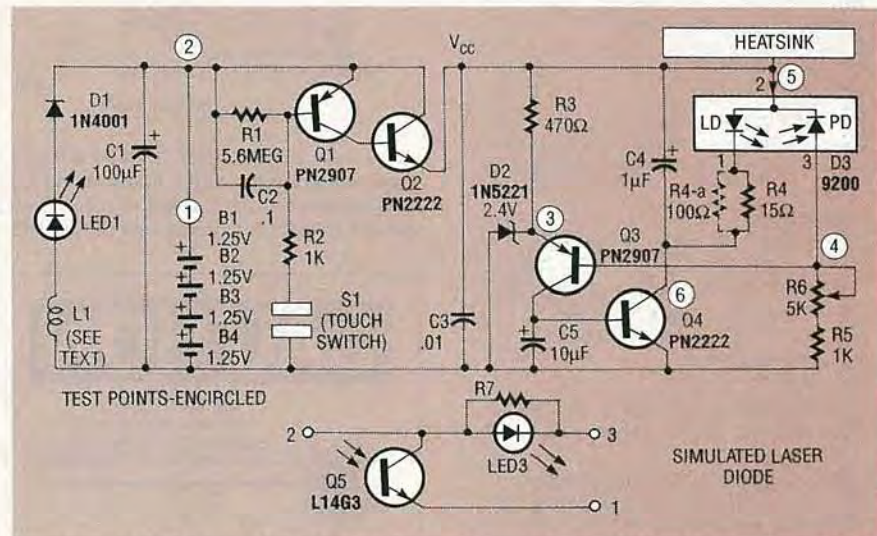

**FIG. 10—HERE'S THE SCHEMATIC** of the hand-held laser. The laser diode (D3) consists of the laser-diode (LD) and photodiode (PD) sections. That allows monitoring of the output energy and produces the feedback necessary to control the circuit.

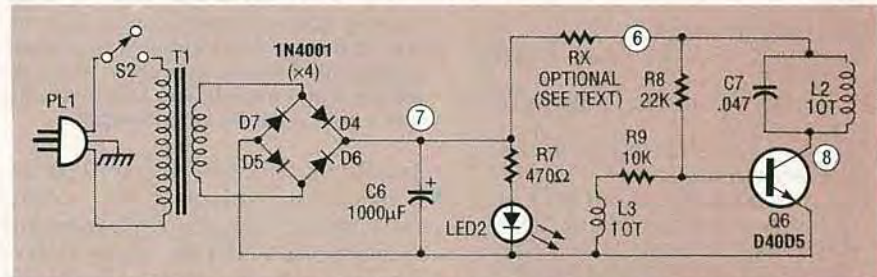
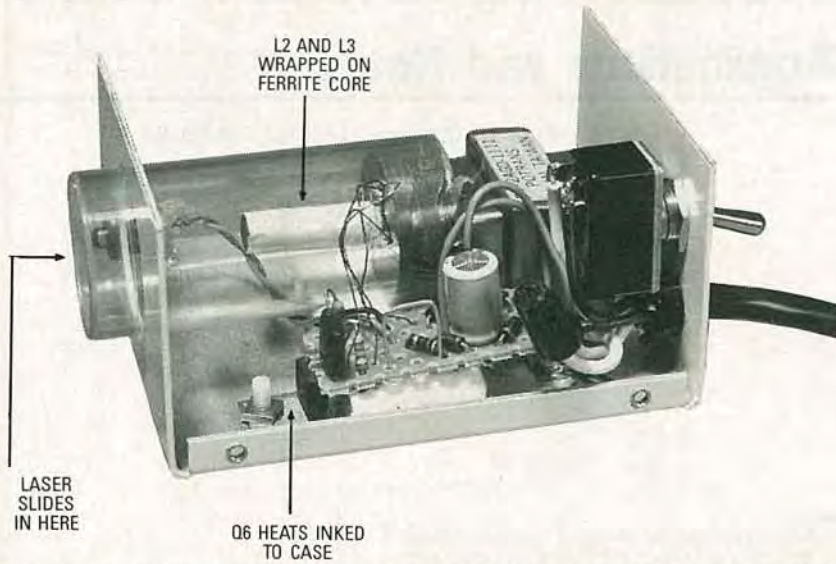

**FIG. 11—THE CHARGER SCHEMATIC**, charging current is inductively coupled to the hand-held laser.

into a grounded AC outlet and check for 12–14 volts DC at test point 7 on the charger schematic. Check to see that LED2 turns on when you close S2.

Open up the lead at test point TP6 on the charger and check for

a reading of 100–125 milliamps (assuming the batteries aren't already charged). In rare cases, if the current is excessively high, a resistor (RX) may be required as shown in the schematic to limit it. If a scope is available you may



**ORDERING INFORMATION**  
 A kit of all parts for the hand-held laser except the laser diode, heat-sink, and retaining hardware (#VRL2-LHK), is available for \$39.50. The special aluminum heatsink and diode retainer with hardware (#HS3) is \$9.50. The price for the Toshiba laser diode (TOLD 9200) is continually dropping, although it is currently \$74.50. A kit of all parts for the charger (#VRL2-CMK) is \$34.50. A kit of parts for the entire system, including batteries and charger is \$158.50. Contact Information Unlimited, P.O. Box 716, Amherst, NH 03031. FAX: 603-672-5406. Toll-free order line: 800-221-1705.

**FIG. 12—THIS IS THE CHARGING UNIT;** the amount of current coupled to it depends on how far the laser is inserted into the charger.  
 in the charger, more or less current is coupled to it.

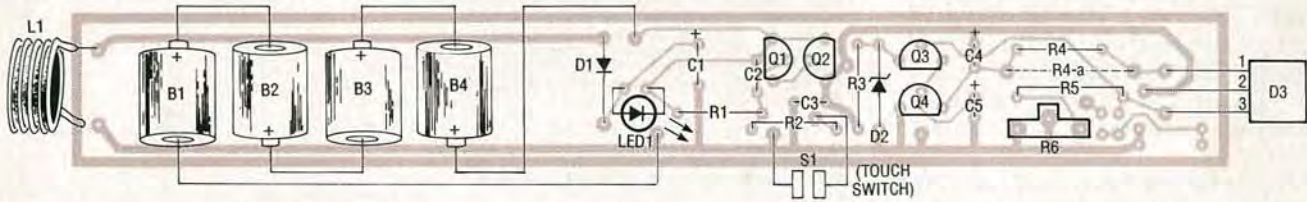

**FIG. 13—PARTS-PLACEMENT DIAGRAM** for the laser. Do not install the laser diode until everything has been thoroughly tested.

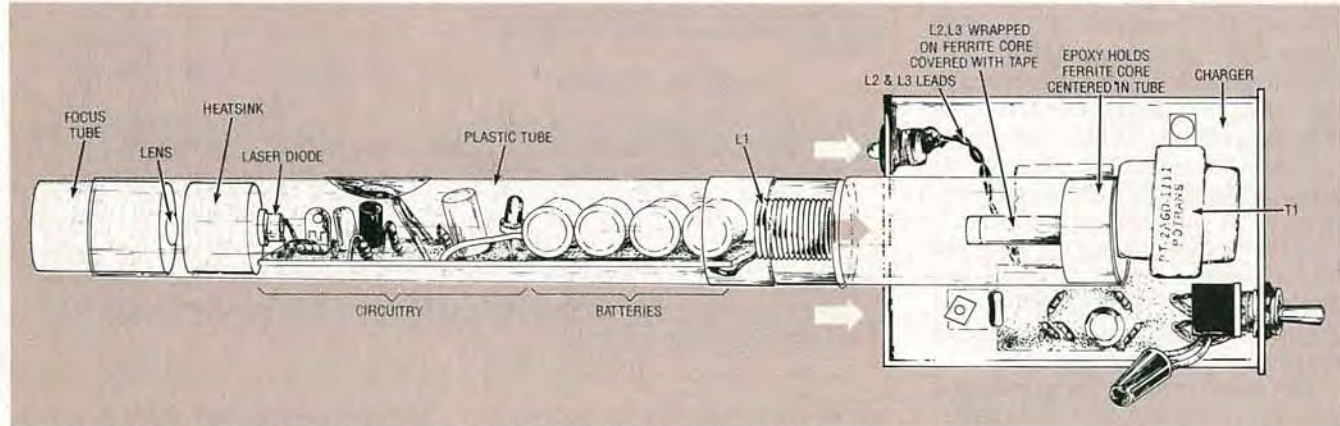

**FIG. 14—The laser section has L1 built inside the handle;** it slides over L2 in the charger.

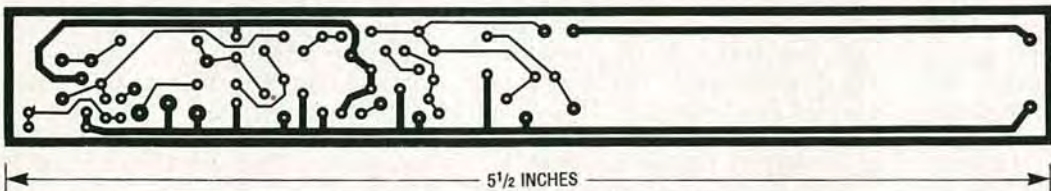

**THIS FOIL PATTERN** for the hand-held laser can be used if you wish to etch your own board.

want to verify an approximate sine-wave shape of 25–30 volts peak to peak at a frequency of 250–300 kHz at test point TP8.

This verifies proper operation of the charger.  
 Connect an ammeter in series with test point 1 on the laser.

Slide coil L1 of the laser over the ferrite core of L2 on the charger. Check for a current reading of 10–25 milliamps and that the charge indicator (LED1) is lit.

The laser may be positioned in the charger socket for either a fast charge of 20 milliamps at a 6–8 hour rate, or the recommended 10 milliamps at a

14 hour rate. Monitor the charging current as you slide the laser in and out of the charger.

Make sure that the batteries are fully charged before you proceed with the following. Remove the laser from the charger. Note that the current goes to zero and LED1 goes out. Check on the lowest meter range; any current flowing into the circuit above a fraction of a microamp will cause premature discharging of the batteries. Check for defective components, flux paths, excessive moisture, etc., if any current is detected in this step.

Using the negative lead of B4 as a ground point, check for 5.6 volts at test point TP2. Adjust R6 to a maximum value (fully counter-clockwise in our layout). Short out the touch-switch leads and note a current of 10–15 milliamps. Remove the short and bridge the leads with dampened fingers; the current flow should be slightly less than the previous reading. This verifies the control circuit.

If you haven't yet built the simulated laser diode (shown in Fig. 10), do so now, and insert it into the circuit. Short out the touch switch and note a current of 75–85 milliamps. The LED should be glowing brightly. Adjust R6 in a clockwise direction to its midpoint and note the current increasing to over 100 mA.

Check for a smooth control, as any jumps can spell disaster, especially at the end of the potentiometer travel. Short the phototransistor section of test laser diode with a 470-ohm resistor to ground. You should note that the current increases further.

The current will also increase if you interrupt the optical link between the phototransistor and the LED. That verifies that the feedback circuit is operating properly. CAUTION: Re-adjust R6 back to maximum resistance (fully CCW). As a reminder, adjustment of R6 must be done with the batteries fully charged.

Remove the touch-switch short. With a metal screwdriver, short out all pins of the laser-diode socket. Do not go any further if you suspect a high-static electrical condition. Wait for a damp day or use a humidifier or vaporizer in your work area. Make sure the touch-switch leads are sepa-

## Applications and Notes

Reprinted with permission from Toshiba's TOLD9200-series application guide.

### An Example of Driving Circuit for TOLD9200

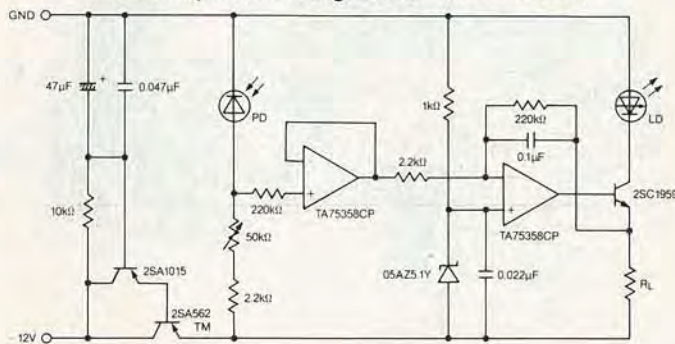

#### Note:

- Use the laser diode after attaching it to a heat sink. Use a larger heat sink during the evaluation stage of deciding the operating condition. A copper or aluminum heat sink is recommended.
- Set the variable resistance VR (50kΩ) for its maximum value, then turn a power supply on. And regulate VR to adjust optical output power.
- When adjusting the optical output power, monitor both the drive current and the optical output power, never exceed the maximum optical output power rating. To monitor the optical output power, use an optical power meter or a calibrated photodiode that has a large active area. In case of using the above driving circuit, the heat sink will have positive potential.

- An Example of the Design of a Heat Sink  
The relationship among the case temperature  $T_c$ , ambient temperature  $T_a$ , and the thermal resistance of the heat sink  $\theta_i$  is shown in the following simplified equation:

$$\theta_i \approx \frac{T_c - T_a}{I_{op} \times V_{op}} - (\theta_s + \theta_c)$$

$\theta_s$ : Thermal resistance of insulator sheet  
 $\theta_c$ : Contact thermal resistance

#### Example:

In the case of  $T_c = 50^\circ\text{C}$ ,  $T_a = 45^\circ\text{C}$ ,  $I_{op} = 100\text{mA}$ ,  $V_{op} = 2.5\text{V}$ ,  $\theta_s = 0$  (no insulator sheet),  $\theta_c = 8^\circ\text{C/W}$ , from the above equation:

$$\theta_i \approx \frac{50 - 45}{0.1 \times 2.5} - 8 = 12^\circ\text{C/W}$$

Heat sink thermal resistance must be  $12^\circ\text{C/W}$  or less. From the figure on the right, the surface area of the aluminum heat sink—assuming it is 2mm thick—must be  $25\text{cm}^2$  in order to obtain a thermal resistance of  $12^\circ\text{C/W}$  or less.

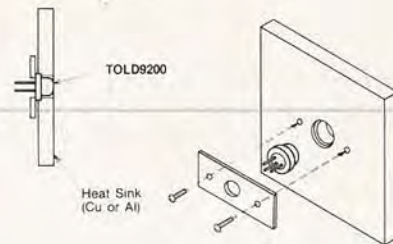
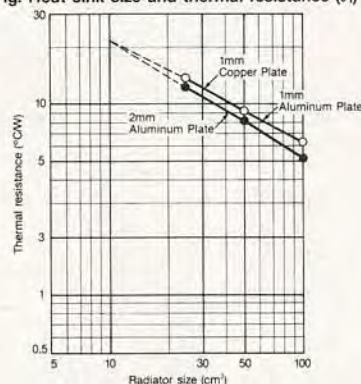

Fig. Heat sink size and thermal resistance ( $\theta_i$ )



#### IMPORTANT NOTICES

The circuit examples illustrated herein are presented only as a guide for the performances of the applications of our products.

Keep in mind that no responsibility is assumed by TOSHIBA for its use, nor for any infringements of patents or other rights of the third parties which may result from its use, and that no license is granted by implication or otherwise under any patent rights of TOSHIBA.

rated and that the meter reads zero current. Carefully insert the diode into the socket.

Bridge the switch with your finger and note the laser diode lighting and a meter current of 70–80 milliamps. The laser diode should be lasing at this level. Short out the touch switch and note slightly higher current.

At this point your laser is producing about 0.5 to 0.7 milliwatts—so you might want to stop here. However, the actual laser-diode current is the meter reading (70–80 mA) minus the 10–20 milliamps at the touch-switch leads, which is still well below the

allowed maximum. So it is possible to get more power out of the laser diode. However, if you do decide to challenge Murphy's laws, the next step should be done with a laser power meter. That's because the output level is critical when adjusting for maximum. We used a *Metrologic* model number 45-540 laser power meter.

Couple the head of the power meter to the laser diode and set it for the 20-milliwatts range. Use a piece of clay for temporarily securing them together. Short out the touch switch and note a

*continued on page 95*

## SEMICONDUCTOR LASER

*continued from page 40*

power output of 0.5 milliwatts or so. *Slowly* rotate R6 noting the "indicated output" on the power meter increasing. Note how "slope" sensitive it is when comparing it to the change on the current meter. That is a direct indication of the slope efficiency of the device as shown in Fig. 9.

**Adjust to an output of 2.4 milliwatts—any more would constitute a more severe optical hazard, and would require a "DANGER" label. An output below 2.4 milliwatts requires only a "CAUTION" class IIIa label. Safety glasses should be worn at this point.**



**PROTOTYPE VERSION** of the simulated laser diode. A hole drilled in the block provides a light path.

Remove the touch-switch short and bridge it with damp fingers; Note the power still going to 2.4 milliwatts, but the current reading on the meter is lower. This verifies the power-control circuitry is functioning properly.

This completes the electronic testing. It is suggested that you return R6 to its lower output adjustment before proceeding. And, again, always make sure that the batteries are fully charged before re-adjusting R6.

R-E