

# MECHATRONICS IN DESIGN

FRESH IDEAS ON INTEGRATING MECHANICAL SYSTEMS, ELECTRONICS, CONTROL SYSTEMS, AND SOFTWARE IN DESIGN

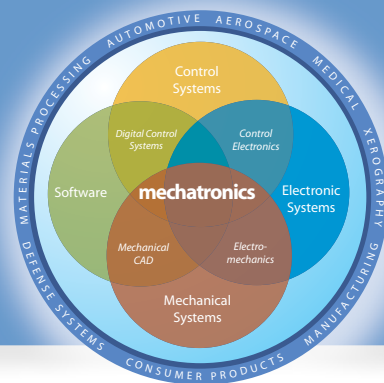

## The significance of poles and zeros

Emulate Wilbur Wright and learn the significance of poles and zeros.

Wilbur Wright's understanding of complex, dynamic problems contributed to his and his brother Orville's successful first airplane flight. Wilbur understood, for example, that, to turn a bicycle to the left, you must first turn the handlebars a little to the right and then, as the bicycle inclines to the left, you must turn them a little to the left. He understood countersteering. In mathematical language, the transfer function between the steer torque applied to the handlebars and the straight-line-path deviation has a right-half-plane zero, which imposes a limit on maneuverability. The path deviation has an inverse-response behavior; that is, in response to a positive step-torque input you apply to the handlebars, the path deviation is initially positive and then becomes negative. This effect has contributed to numerous motorcycle accidents, but countersteering could prevent these accidents.

To better understand the physical significance of the poles and zeros of a transfer function, consider a simpler system, comprising two rigid links and a torsional spring (see **Figure 1**). Assume small displacements. The equations of motion, shown in the online version of this article at [www.edn.com/120419mech](http://www.edn.com/120419mech), are in matrix form, along with two transfer functions,  $G_0(s)$  and  $G_1(s)$ .

A pole of a transfer function is a value of  $s$  that makes the denominator equal to zero, and a zero of a transfer function is a value of  $s$  that makes the numerator equal to zero. Systems that have no poles or zeros in the right half of the complex plane are minimum-phase systems because either of the two components of the frequency response, gain and phase, contains all the frequency-response information that exists. This phenomenon, Bode's gain-phase relationship, stipulates that systems that have poles in the right half of the plane are unstable. A nonminimum-phase stable system is one that has a zero in the right half of the plane. Physical phenomena that give rise to nonminimum-phase stable behavior include control of

the level of a volume of boiling water and hydroelectric power generation.

The denominators of both transfer functions are identical. The double pole at the origin represents the rigid-body motion of the system. The complex-conjugate pole pair represents the natural frequency associated with the energy-storage characteristics, including kinetic and potential energy, of the physical system. They are independent of the locations of the sensor ( $\theta_0$  or  $\theta_1$ ) and the actuator (T). At a frequency of the complex pole, energy can freely transfer back and forth between the kinetic and the potential energy, and the system behaves as an energy reservoir.

The numerators of the two systems differ greatly. The complex zero represents the natural frequency associated with the energy-storage characteristic of a subportion of the system.

The sensor and the actuator impose artificial constraints that define this subportion. These constraints include the resonant frequency of the second link when the first link is fixed. It is lower than the natural frequency of the system, and it corresponds to the frequency at which the system behaves as an energy sink, such that the energy-storage elements of a subportion of the original system completely trap the energy that the input applies. Thus, no output can ever be

detected at the point of measurement. The zero in the right half of the plane is a nonminimum-phase zero and gives rise to the same characteristic initial inverse response that Wilbur Wright observed in the bicycle. The locations of the poles and the zeros of a transfer function are the result of design decisions and can make control easy or difficult. **EDN**



Kevin C. Craig, PhD, is the Robert C. Greenheck chairman in engineering design and a professor of engineering at the College of Engineering at Marquette University. For more mechatronics news, visit [mechatronicszone.com](http://mechatronicszone.com).

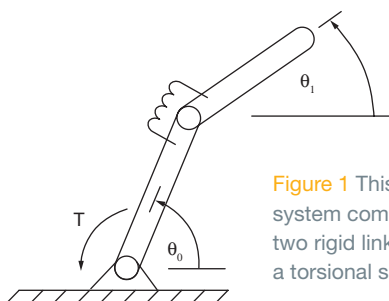

**Figure 1** This system comprises two rigid links and a torsional spring.