

PRODUCT No. 23602

ASAHI PENTAX **K2**
SERVICE MANUAL



B. Disassembly

There are some parts which have to be taken off with careful treatment.

1. Top cover (A300) removal

Wind lever should be set at closed position before taking off top cover.

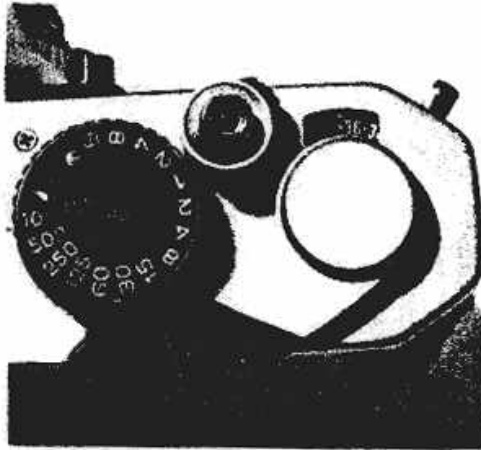

AT CLOSED POSITION

Fig. 1



AT PREADVANCE ANGLE

Fig. 2

2. Photo sensor circuit board assembly (T300) removal

K2 camera is controlled with very small electric current (ex. 200pA or 300pA), therefore all electric parts should be treated carefully, especially, photo sensor circuit board; it is so sensitive that it should not be touched with bare hands.

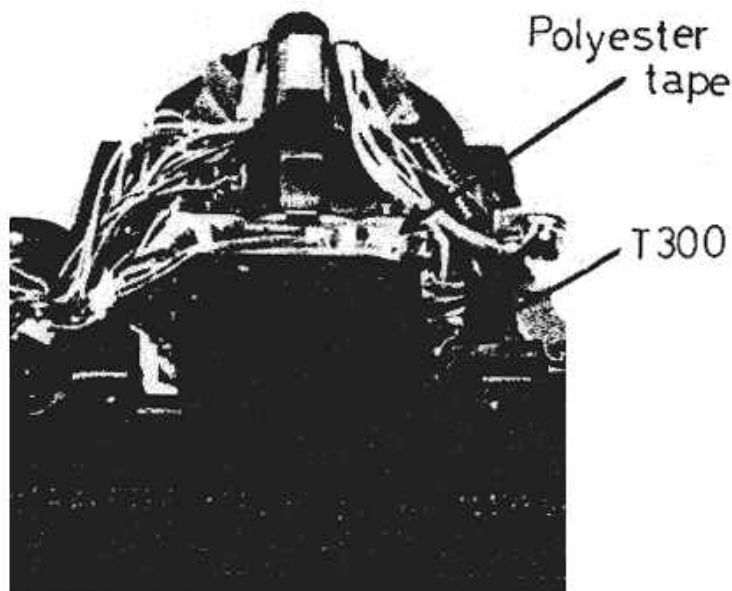

Fig. 3

3. P.C. board pattern assembly (T100) removal
 P.C. board pattern assembly (T100) can be taken out with or without removing Front Board. Pull it out hooking the large black I.C. with spring hanger. Don't touch the other I.C.s or electric parts.

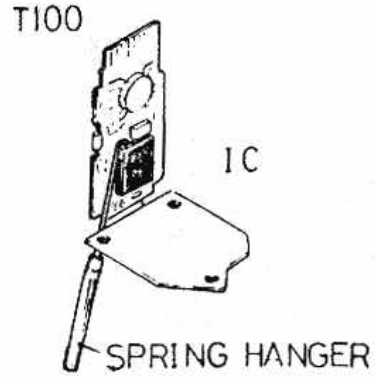

Fig. 4

4. Front board removal
 Front board can be removed without taking off Self-Timer lever or covering, as shown in photograph.

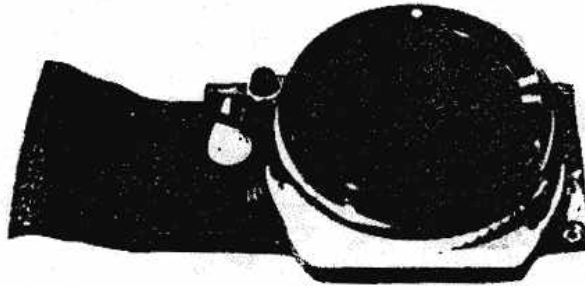

Fig. 5

5. Shutter mechanism (E000) removal
 Shutter mechanism (E000) is so delicate and sensitive that it should not be touched with bare hands except the parts as shown in the photograph. It may cause malfunctions if handled roughly.

Use finger cover for removal.

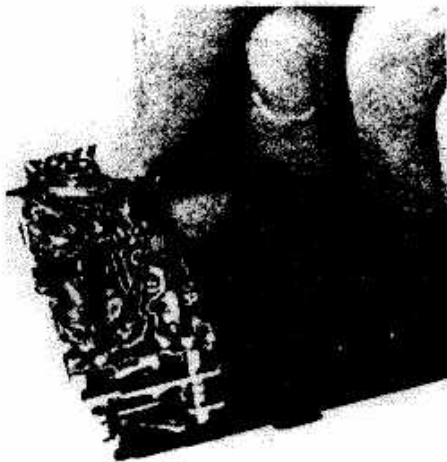

Fig. 6

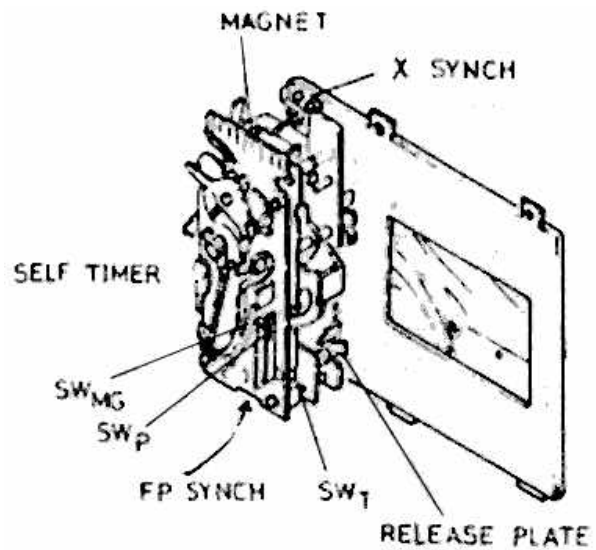

Fig. 7

C. Assembly and adjustments

Some parts should be assembled and adjusted. with careful treatment as shown in the following.

1. Winding stopper assembly (0-C6)

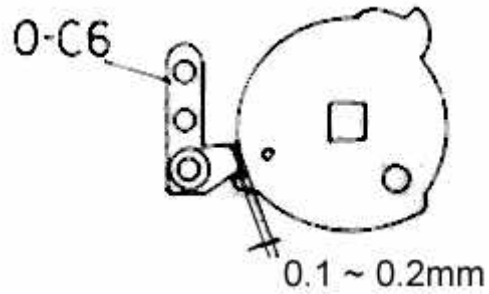

Fig. 8

2. Winding spring (0-C23)

Face the retainer screw of spring in the direction of Tripod socket, and wind the spring a little and stretch it in the direction of tripod seat. The proper tension is obtained when it is stretched around Tripod socket

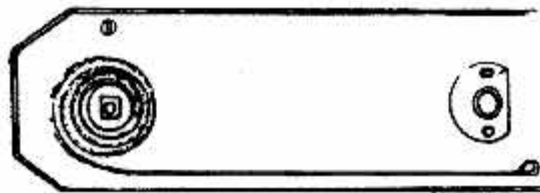

Fig. 9

3. Perforation Adjustment

There are several kinds of 2nd gear (C205) which are selected to achieve the proper position of socket teeth. After removing 2nd gear, set sprocket (C9) in the correct position using the tool (23600 N-A1, C9-A)

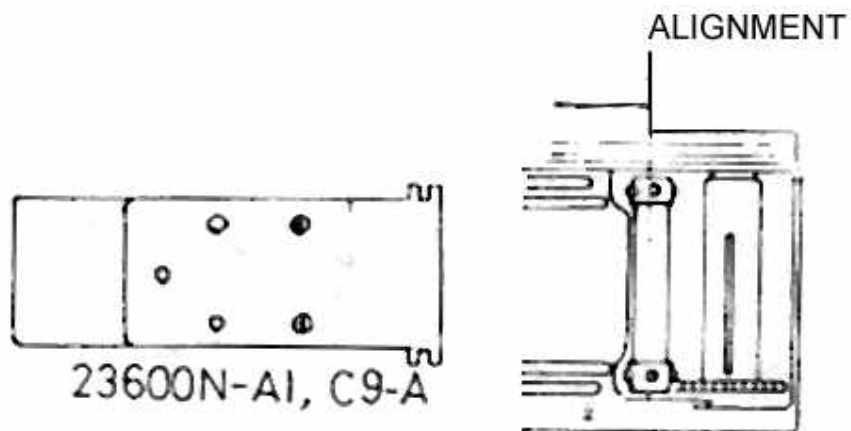

Fig. 10

Wind up top 2nd mech. plate assembly (C200) with driver and loosen wind shaft without moving main gear. Then give back-tension to sprocket gear (C16)
 Choose the proper coupling 2nd gear (C205) and install it in the above-mentioned way.

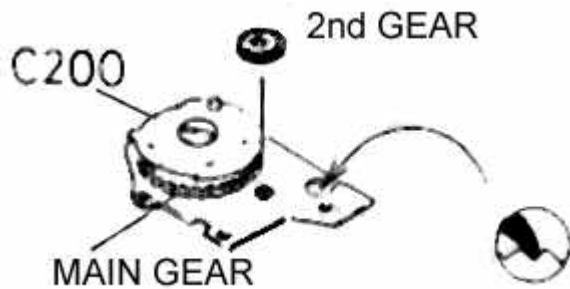

Fig. 11

4. Memory block assembly (T400)

After cocking mirror housing, 0.2mm clearance is necessary between delrin and the longer contact piece of memory block (T400) — See Fig. 12 A

After releasing mirror housing and when mirror stays up, also 0.2mm clearance is necessary between two contact pieces of memory block. See Fig. 12 B

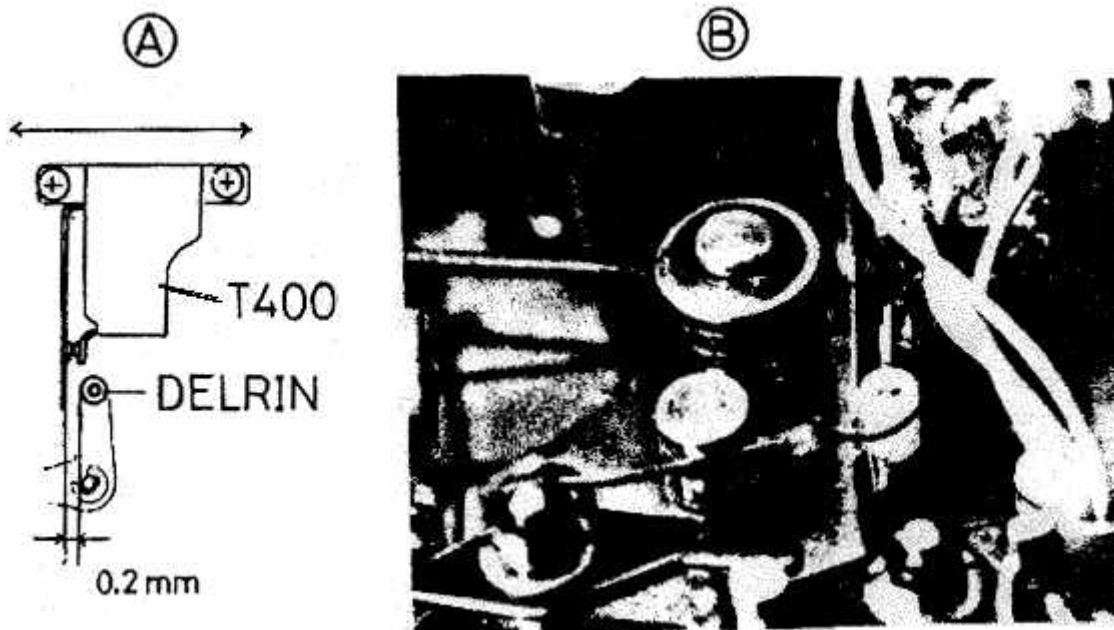

Fig. 12

5. Shutter dial seat assembly (F000)

Set shutter dial at "B", and pull meter coupling plate assembly (0-A8) toward counter dial block. Otherwise, shutter mechanism will not work properly.

6. Blue needle adjustment

- (a) Set shutter dial to "AUTO". Install Idle gear holder assembly (0-A12) gearing 2/3 portion with the gear of (galvanometer (q 1))
 Idle gear holder assembly (0-A12) should never touch shaft receptacle assembly (0-D5), and the clearance is approximately 0.2-0.3mm.

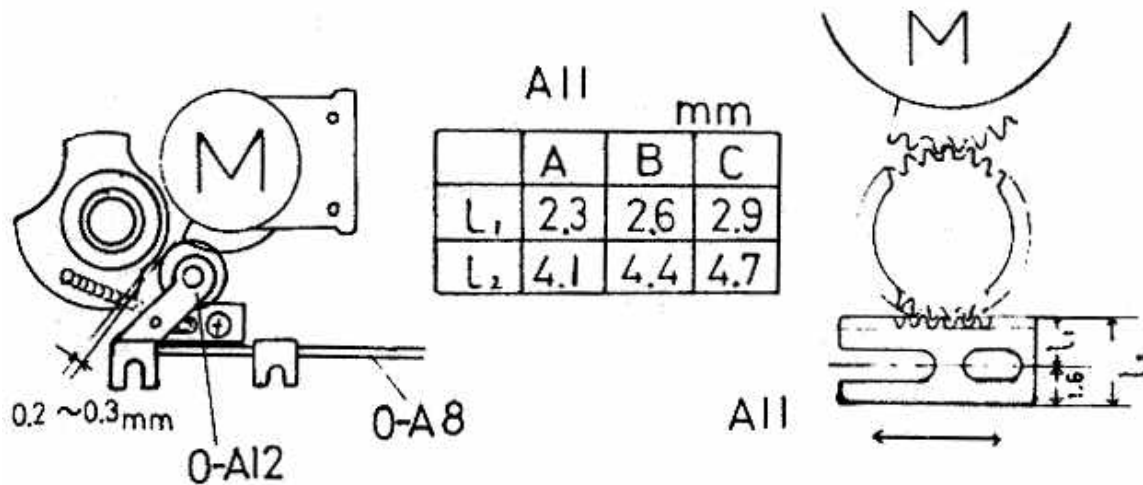

Fig. 13

- (b) Pull meter coupling plate assembly (0-A8) toward shaft receptacle assembly (0-D5). Install rack (A11), attaching its concave part to the rivet of meter coupling plate assembly (0-A8).
 Three kinds of rack (A11) of different widths are used for adjustment to achieve smooth function of the blue needle.
- (c) When shutter dial is turned from "B" to "AUTO" or vice versa, meter-coupling plate assembly (0-A8) must function smoothly even without meter coupling spring (A15). After checking function, meter coupling spring (A15) is installed.
- (d) Blue needle is adjusted by moving rack (A11) left -or right, so that blue needle matches with each step of shutter speed scale when shutter dial is turned.
- (e) Apply red lacquer to screws and Plio-Bond to meter coupling spring (A155) after finishing adjustment.

7. Stroke adjustment

After putting on top cover (A300) and wind lever assembly (0-C132), set shutter dial to "B", Wind lever should be set at closed position.

Procedure

(a) No clearance is allowed between release plate (A503) and the lever of shutter mechanism (E000). and also the lever should not be pushed by release plate.

(b) After shutter cocking, adjust clearance to 0.3mm between Mirror Actuator lever hook plate assembly (0-B48) and its hitting part. (Adjusting screw 1)

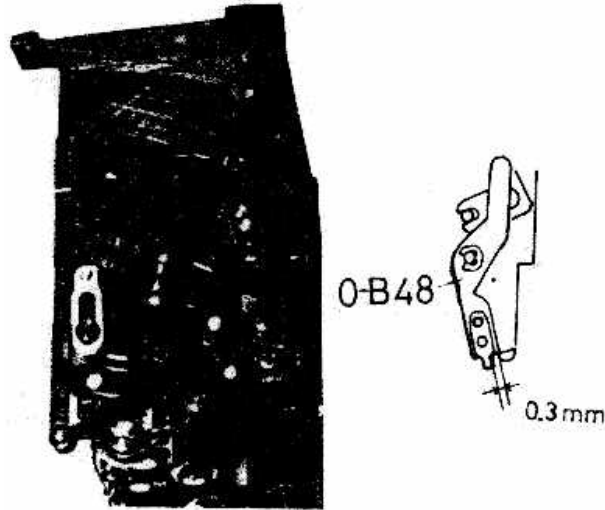

Fig. 14

(c) Shutter stroke adjustment
Depressing shutter button gradually, shutter starts working at $2.3\text{mm} \pm 0.2$ deep from original position. (Adjusting screw 2)

(d) Self timer stroke
0.1 mm deeper than shutter stroke
(Adjusting screw 3)

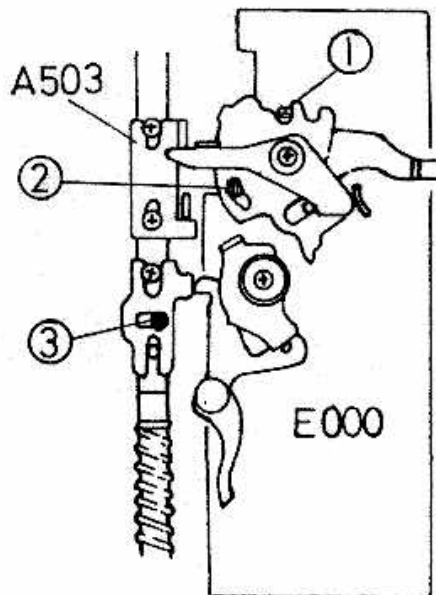

Fig. 15

8. Function check of SWp

“ON” When release button is gradually depressed and before it reaches to keep-position, SWp should be on”.

“OFF” When wind lever is set at closed position.
When release button is depressed with “Lock”

9. Shutter speed adjustment:

Testers: Light value correction unit. TSST-3A. T adjuster (or battery), ESST-1A, digital counter, diaphragm setting ring (KA-00-1A), 23600K-A400-A.

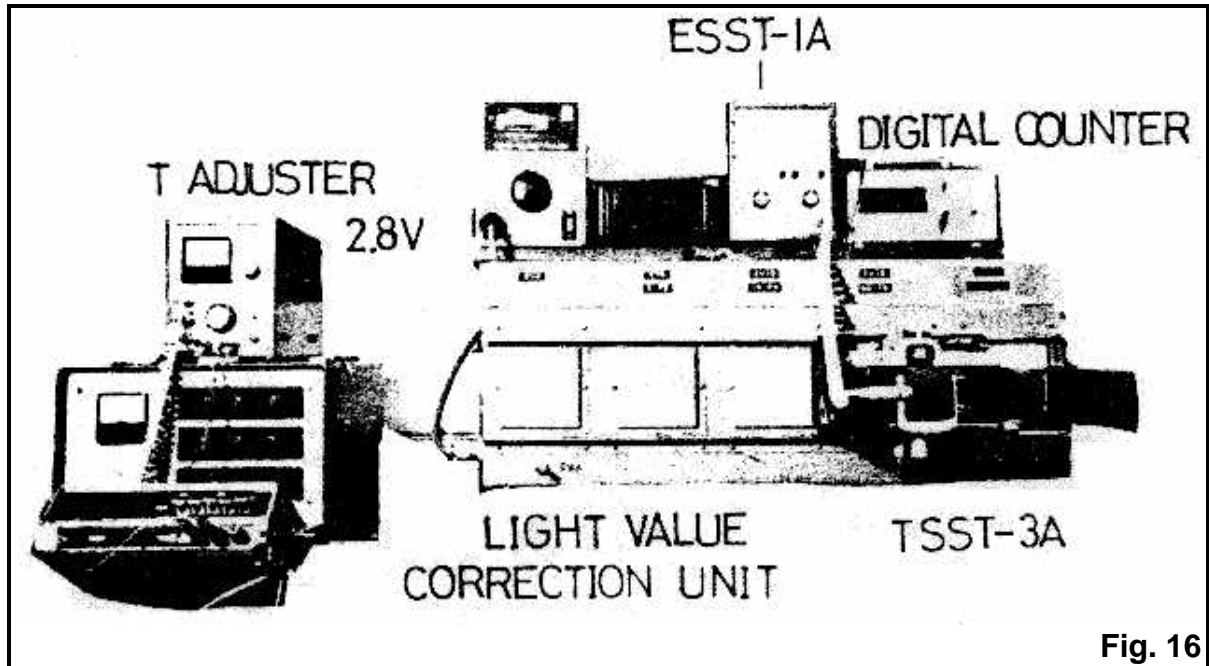

Fig. 16

Procedure:

(a) Auto speed adjustable resistor R7
(1X, ASA100, 2.8V)

EV12	—	1/60 sec
EV16	—	1/1000
EV16(2X)	—	1/500
EV8	—	1/4
EV4	—	1

(b) Meter level — R10

EVI6	—	1/1000sec
------	---	-----------

(c) Meter sensitivity — R9

EV8	—	1/4
-----	---	-----

(d) Manual shutter speed — R12

EV12	—	1/60
------	---	------

(check all shutter speeds to see Rotary SW contact effects)

(e) Battery Checker

2.1V	OFF
2.4V	ON

(No adjustment is allowed because no tester is supplied).

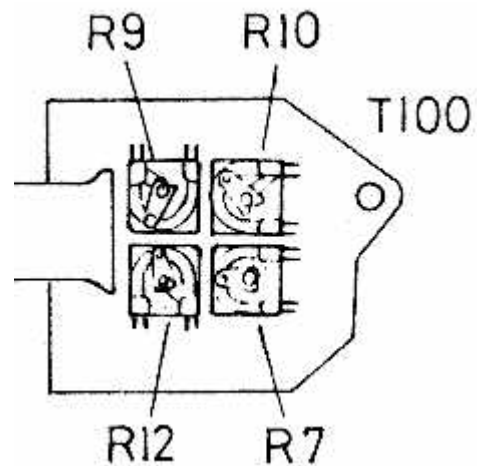

Fig. 17

10. Galvanometer installation

Tester: Meter tester (MA-00-01)

Needle must be absolutely horizontal between 15 and 8. Check the movable range of the needle in the upper and lower part.

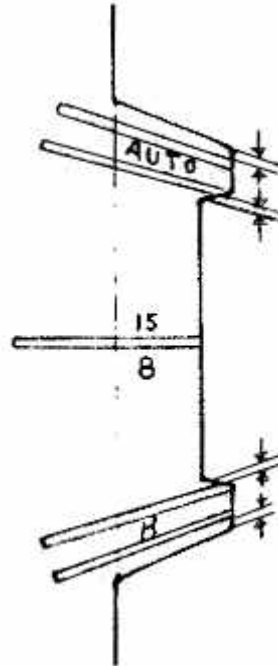

Fig. 18

11. Shutter release adjustment

As shown in Fig. 19, when mirror housing is released, dimension between Shutter Actuator plate (B61) and minor housing foot. should be kept at 9.4 ± 0.1 mm.

The longer Shutter actuator plate (B61) will break Shutter mechanism (E000), and the shorter one will never make it (E000) function.

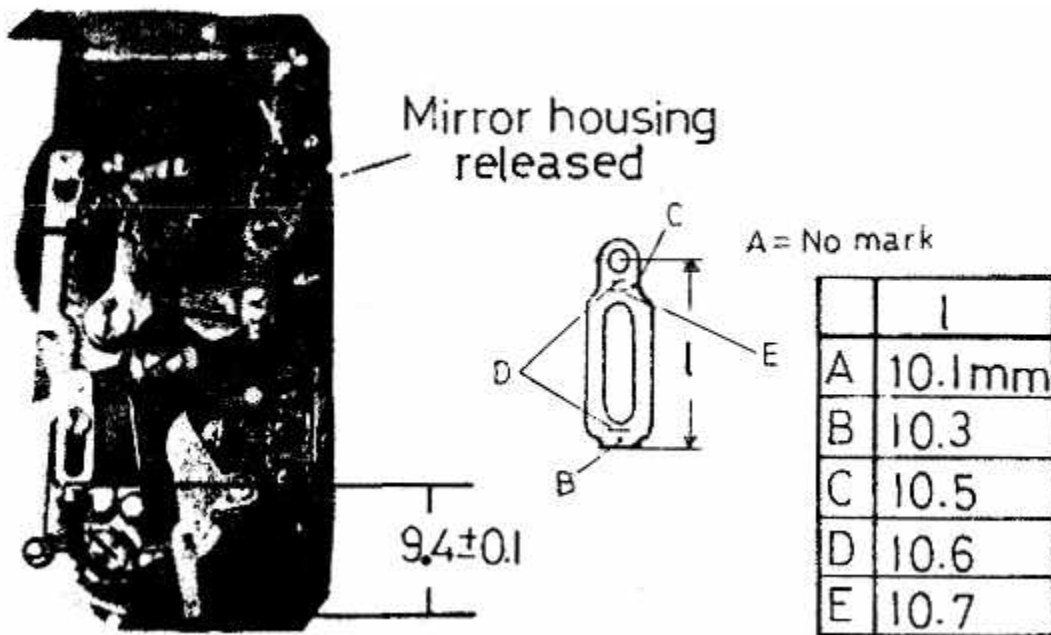

Fig. 19

- D. Lubricants
- | | | |
|-----|---|----------------------------|
| G21 | — | Mainly used |
| G31 | — | 0-B25, 0-B48, 0-B68, 0-B22 |
| L | — | On rewind shaft (D6) |

E. Special tools

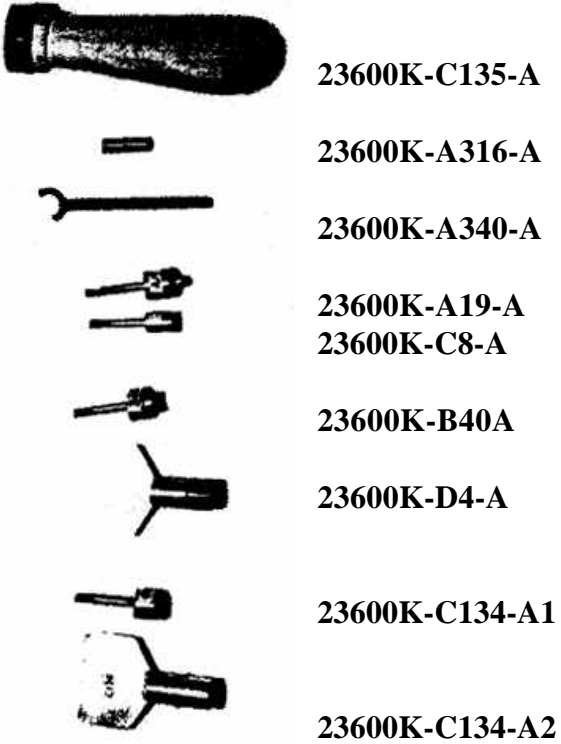
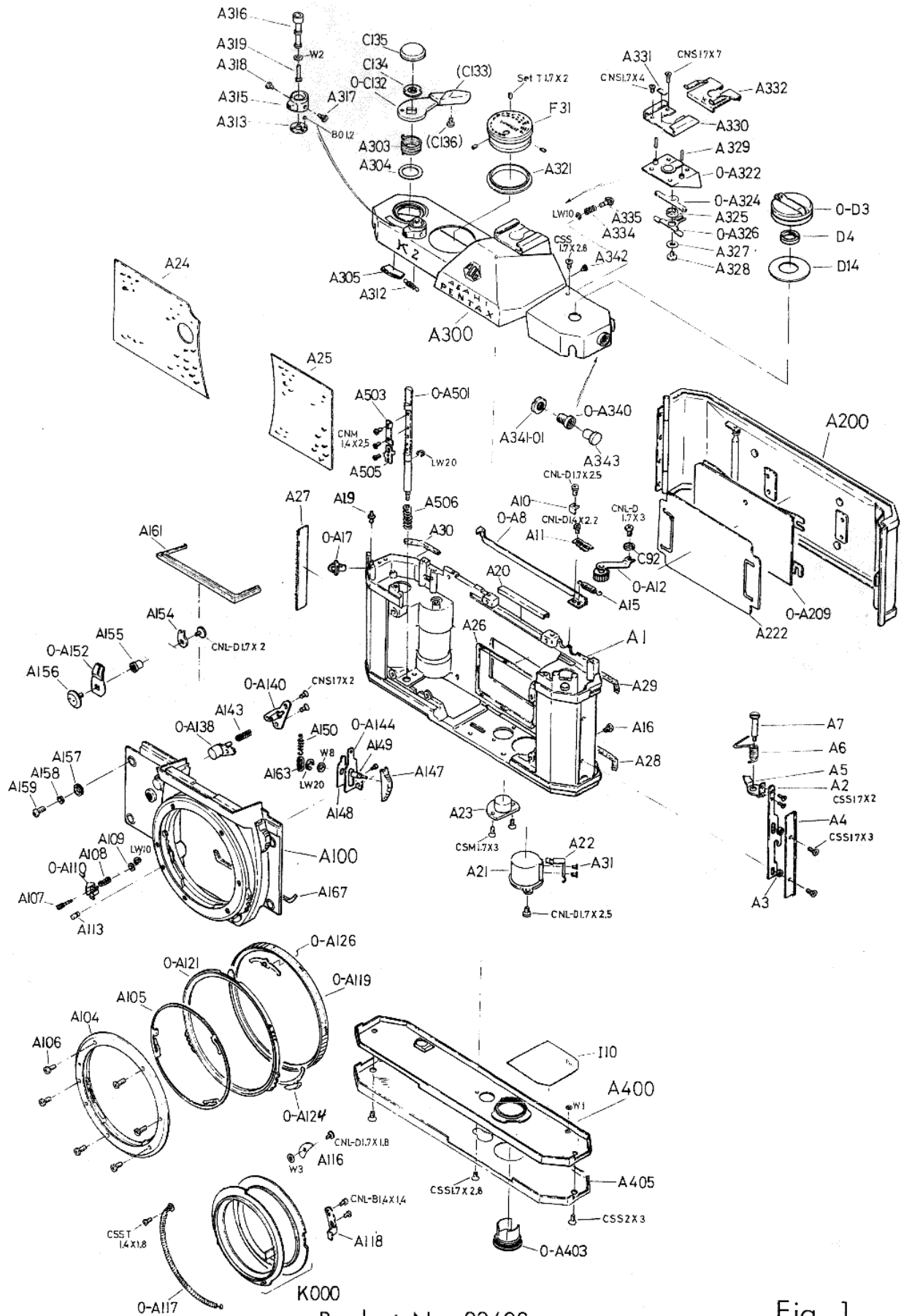

Fig. 20

EXPLODED ILLUSTRATION



Product No. 23602
ASAHI PENTAX K2

Fig. 1

EXPLODED ILLUSTRATION

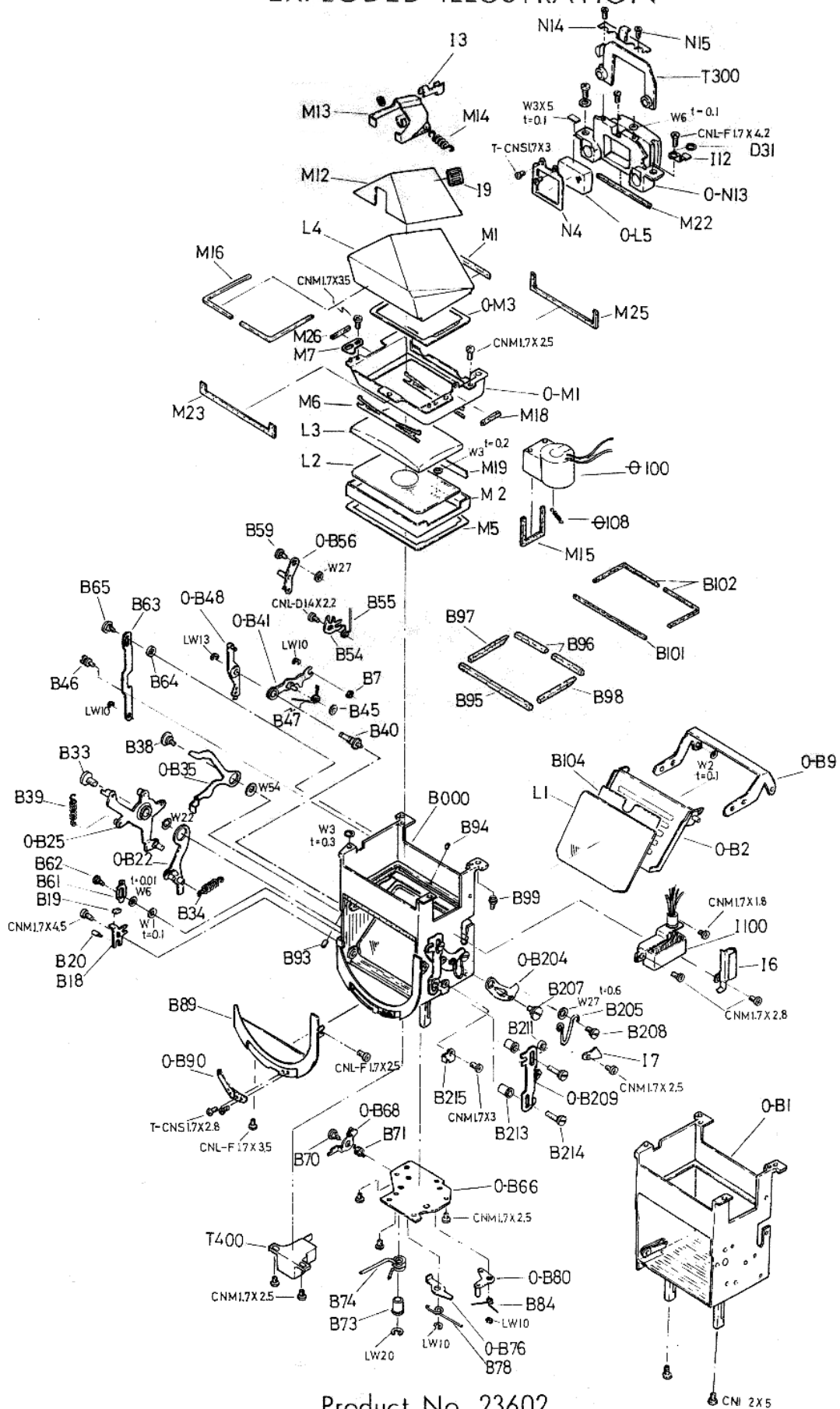

Product No. 23602
ASAHI PENTAX KC2

Fig. 2

EXPLODED ILLUSTRATION

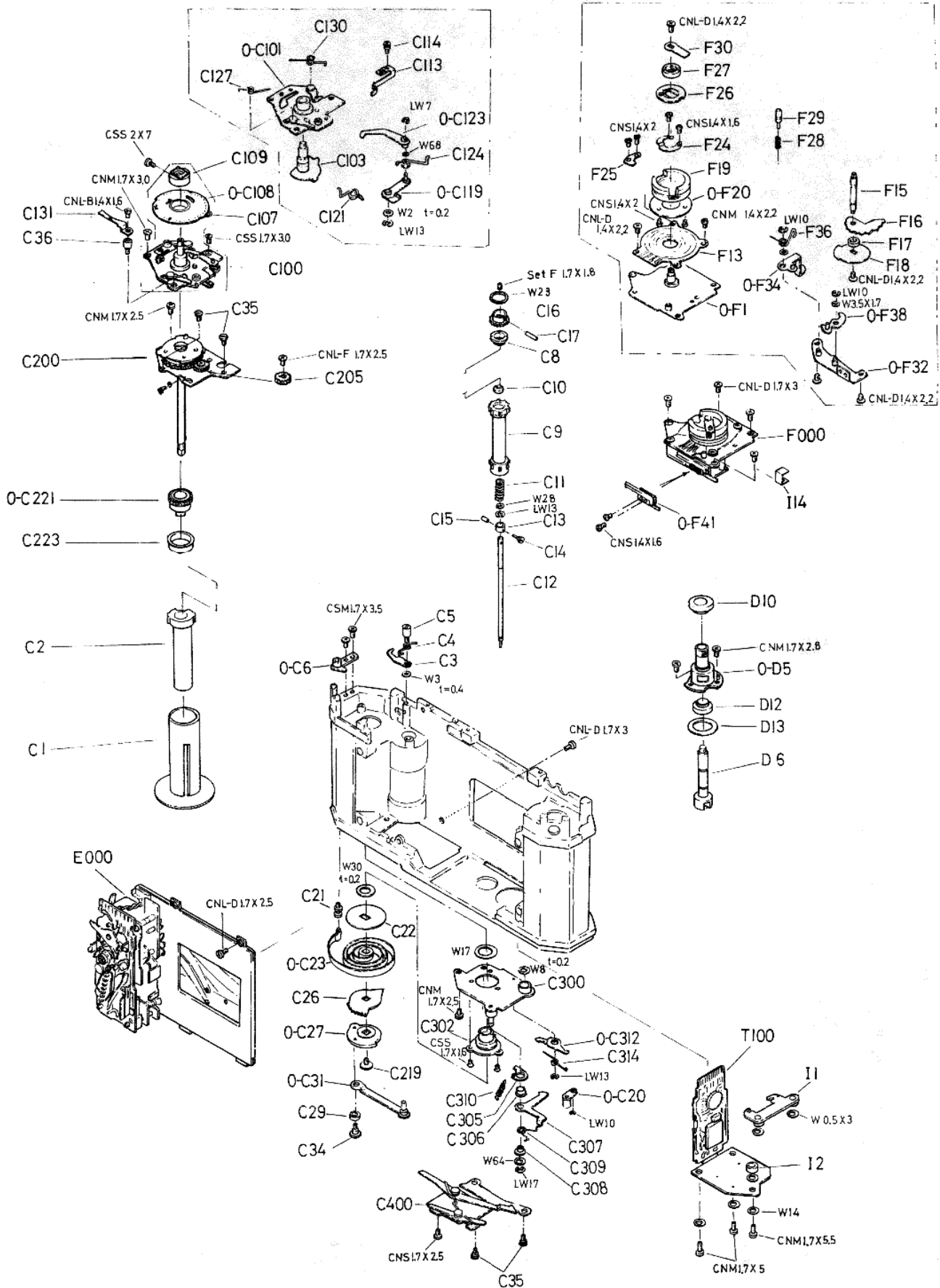

Product No. 23602
ASAHI PENTAX **K2**

Fig. 3

DISTRIBUTING WIRES

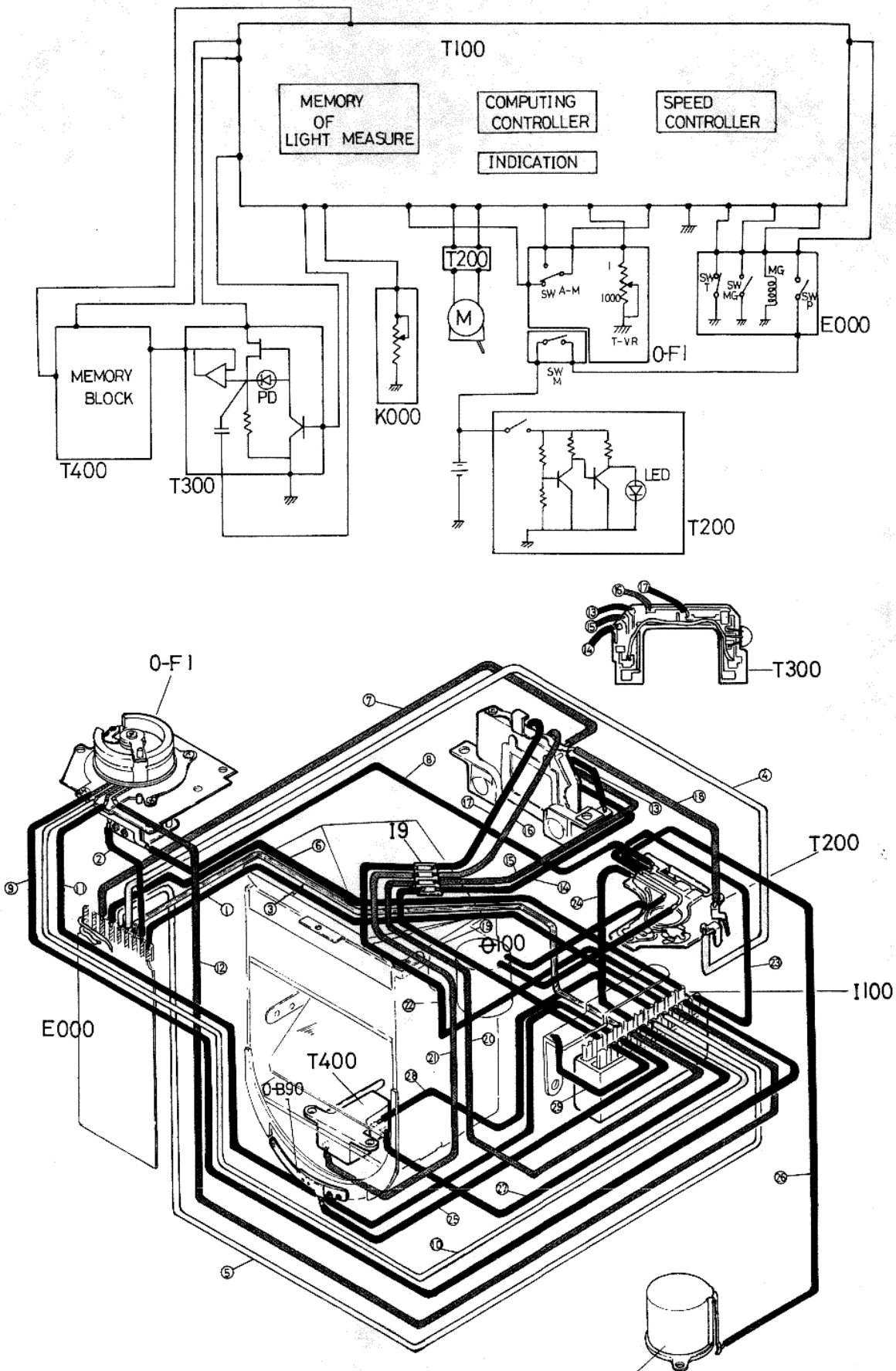

Product No. 23602 A21
ASAHI PENTAX K2

Fig. 4