

Applause Meter

Dec. 20, 1985 © Daniel A. ... Vancouver, B.C.

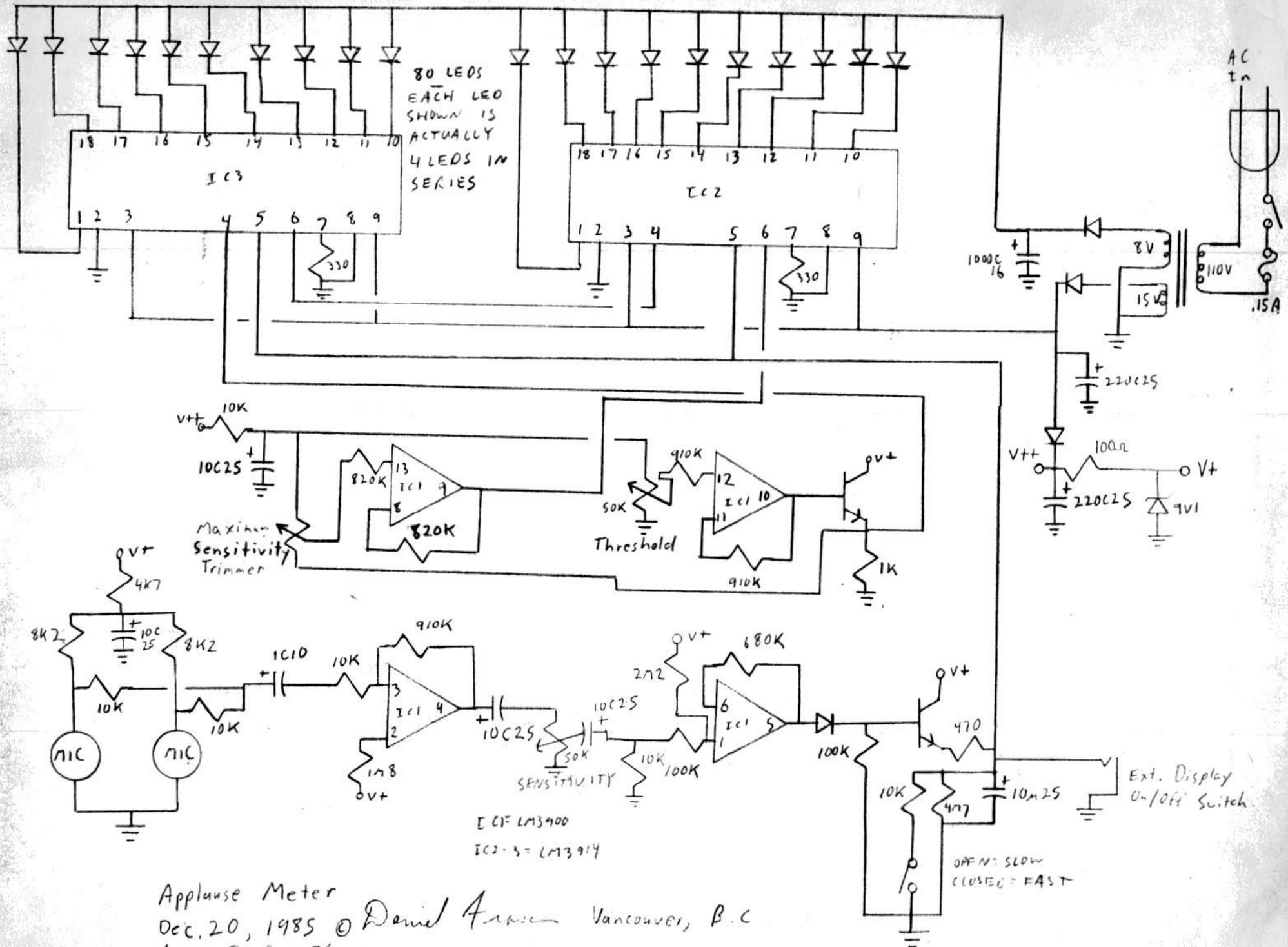

Applause Meter

Dec. 20, 1985 © Daniel Arsen Vancouver, B.C.

Revised Jan. 3, 1986

APPLAUSE METER by Fraser Electronics

The applause meter is intended to help judge events by the level of sound generated by applause. The unit is to be hung from the stage ceiling and to be plugged into normal 120 Volt AC power. The remote unit is mounted in the DJ booth.

The display consists of 4 rows of 20 LEDs. The numbers 1 to 10 are placed beside every second LED. The LEDs are controlled by a circuit with a logarithmic characteristic. That means each light represents a level 3 decibels above the next lower one. To the non-technical person, this means that to light up a LED requires double the sound energy required to light up the previous one.

CONTROLS

The controls are: the power switch, slow/fast switch, threshold control, sensitivity control and on the remote control, the display on/off switch.

POWER - This turns the meter on or off.

SLOW/FAST SWITCH - In the fast position, the display goes up and down in time to the sound level. When the sound level drops, so does the display. In the slow position, the display shows the highest level reached, holding it there and going down very slowly on its own. If left, however, the display will eventually go down to zero over a period of several minutes.

DISPLAY ON/OFF SWITCH - This switch allows the DJ to keep the meter off until he wants a reading. When he turns the display on, the meter is activated and the display may be seen by the audience.

THRESHOLD CONTROL - This control sets the level at which the first LED will light. This control is provided for the user to set the meter so extraneous noise in the room does not trigger the meter.

SENSITIVITY CONTROL - This control sets the sensitivity of the meter. Turn it clockwise for more sensitivity and counter clockwise for less sensitivity.

OPERATION

After setting both the sensitivity and threshold controls fully clockwise and putting the fast slow switch into the fast position, turn it on. With the normal room noise present, one or more LEDs may be lit. If so, turn down the threshold control so that the bottom LED just goes out. If no LEDs are lit when you start, leave the threshold control alone.

Next with the fast/slow switch to the FAST position, if possible, get the audience to give a loud round of applause. This need only be for 2-3 seconds. During this time adjust the sensitivity control so that the LEDs are lit up to the "7" or "8" mark. Now move the fast/slow switch to the SLOW position. The meter is now ready for use.

If when judging a contest, you find you are getting too many "TENS", you may set the sensitivity control downwards, but keep in mind you have, in effect, changed the rules and previous part of the contest is not really valid as the rest of the contestants will get lower scores. This should only be done when going from a preliminary round to the final round of judging.

The preceding assumes the display on/off switch is on the ON position. When in normal use, the display on/off switch will be OFF. Then, when the DJ wants to get a reading, it is turned ON.

After the score has been noted, turn the display switch back off.

APPLAUSE METER by Fraser Electronics

The applause meter is intended to help judge events by the level of sound generated by applause. The unit is to be hung from the stage ceiling and to be plugged into normal 120 Volt AC power. The total power consumption is under 10 Watts.

The display consists of 4 rows of 20 LEDs. The numbers 1 to 10 are placed beside every second LED. The LEDs are controlled by a circuit with a logarithmic characteristic. That means each light represents a level 3 decibels above the next lower one. To the non-technical person, this means that to light up a LED requires double the sound energy required to light up the previous one. The display range is thus 60 decibels, covering a 1,000,000 to 1 range in sound intensity.

CONTROLS

The controls are: the power switch, slow/fast switch, threshold control and sensitivity control.

POWER - This turns the meter on or off.

SLOW/FAST SWITCH - In the fast position, the display goes up and down in time to the sound level. When the sound level drops, so does the display. In the slow position, the display shows the highest level reached, holding it there and going down very slowly on its own. If left, however, the display will eventually go down to zero over a period of several minutes.

THRESHOLD CONTROL - This control sets the level at which the first LED will light. This control is provided for the user to set the meter so extraneous noise in the room does not trigger the meter.

SENSITIVITY CONTROL - This control sets the sensitivity of the meter. Turn it clockwise for more sensitivity and counter clockwise for less sensitivity.

OPERATION

After setting both the sensitivity and threshold controls fully clockwise and putting the fast slow switch into the fast position, turn it on. With the normal room noise present, one or more LEDs may be lit. If so, turn down the threshold control so that the bottom LED just goes out. If no LEDs are lit when you start, leave the threshold control alone.

Next move the fast/slow switch to the slow position. Now, if possible, get the audience to give a loud round of applause. This need only be for 2-3 seconds. After they have finished, adjust the sensitivity control so that the LEDs are lit up to the "7" or "8" mark. It is now ready for use.

If when judging a contest, you find you are getting too many "TENS", you may set the sensitivity control downwards, but keep in mind you have, in effect, changed the rules and previous part of the contest is not really valid as the rest of the contestants will get lower scores. This should only be done when going from a preliminary round to the final round of judging.

When judging a contestant, the slow/fast switch should be in the slow position. However, after the score has been noted, the meter will take several minutes to reset itself to zero. To reset it quickly, the emcee should move the slow/fast switch to the fast position for a second and then return the switch to the slow position for the next contestant.