

Circuit Ideas

Motor revolutions control

In d.c. motor applications this circuit will provide an exact number of revolutions. By using a small resistance, R_s , in series with the motor, a voltage is developed across it which contains an a.c. component whose amplitude and frequency are related to the speed of rotation and the number of armature coils. This signal is amplified by a c.m.o.s. inverter operating in the linear mode. The two following inverters square the signal which is then fed into the counters. The counter outputs are decoded by gate 1 which controls the series switching transistor Tr_1 . Gate 2 in conjunction with Tr_2 is used to brake the motor. Thus, when the desired number of revolutions is reached Tr_1 turns off and Tr_2 turns on which rapidly stops the motor. Gate 3 isolates the counters during the braking period. The motor is restarted by pushing the reset button. If the motor is slowed down due to unusual loading conditions it will always complete the desired number of revolutions.

R. McGillivray,
Toronto,
Canada.

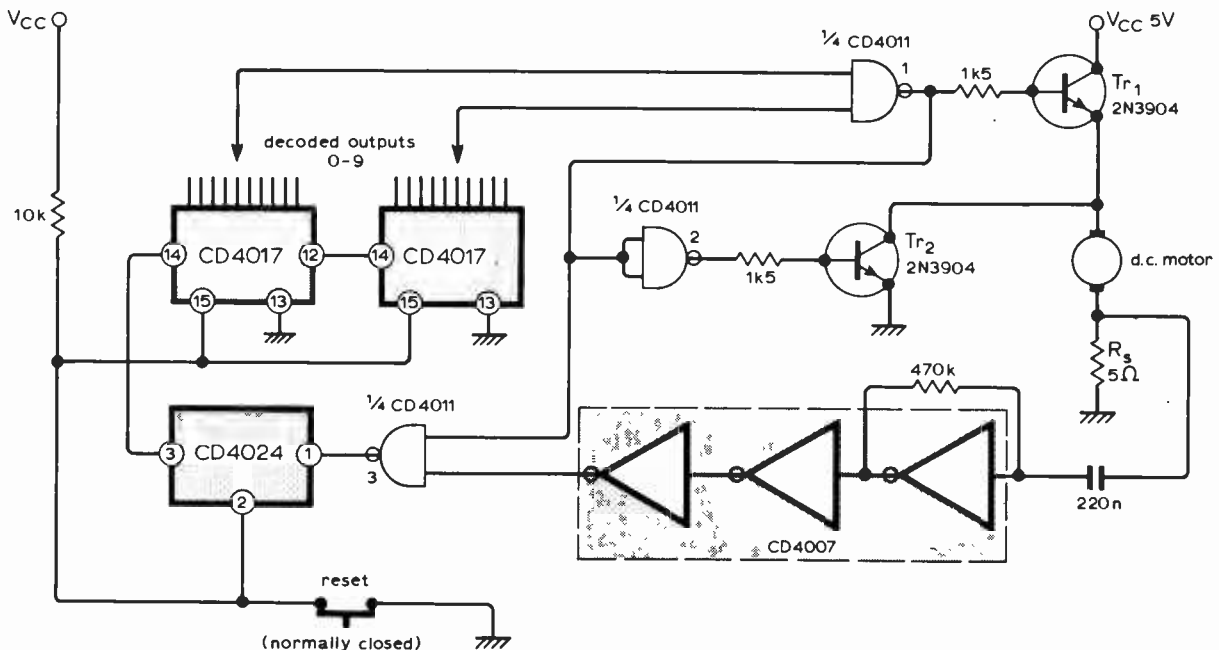

Temperature to pulse-length converter

An output pulse whose length is directly proportional to temperature can be produced by using a thermistor in the circuit shown. The design is based on the similarity between the resistance/temperature curve of a thermistor $R_{T1} = R_{T0} \cdot e^{(B/T1 - B/T0)}$ and the inverse function of voltage across a capacitor charging through a resistor from a voltage after time $t, V_1 = V_0 - V_0 \cdot e^{-t/CR}$. Temperature is measured by the thermistor which is supplied from a potential divider to reduce dissipation. The temperature dependent current through the thermistor appears as a voltage across R_1 . This is compared by IC_1 with a fraction of the increasing voltage across C_1 . The output of IC_1 goes negative and triggers the 555 which is connected as a monostable. The 555 output turns the transistor on for about $100\mu s$ and discharges C_1 .

The timer output can be used to gate a clock oscillator so that the resulting number of pulses will be directly proportional to temperature. Alternatively, the output can drive a pulse-length to voltage converter for an analogue output. If a true reading in degrees C is required, the pulse length corresponding to 0 deg C must be subtracted. This may be achieved either by gating the output with a second monostable or by a digital counter operating on the gated clock pulses.

The prototype circuit produced a pulse length of $650\mu s$ at 0 deg C, increasing by $20\mu s/deg C$, and was accurate to within $\pm 1.2 deg C$ over the range 0 to 60 deg C.

Other temperature ranges or thermistor types can be used with suitable changes of R_1, R_2 , and R_3 .
T. P. Y. Sander,
Bembridge,
Isle of Wight.

