



DESIGN NOTES

Number 10 in a series from Linear Technology Corporation

May, 1988

Electrically Isolating Data Acquisition Systems

Guy Hoover
William Rempfer

Introduction

In data acquisition systems it is often necessary to electrically isolate the measurement points from the system controller. Reasons for the electrical isolation include the following: to allow floating measurements at high voltages; for safety, to reduce the danger of electrical shock, as might occur in medical applications; and to eliminate ground loops between measurement points and the system controller which can cause errors.

The data transmitted over the isolated lines can be either analog or digital. Analog signals have poor noise immunity and one isolator is required for each signal point. Traditionally, the highly noise immune, digitally encoded signals required many isolated lines for each channel. Now, with the LTC1090 family of serial data acquisition systems, it is possible to transmit eight channels of data with only four isolated lines. Each additional eight channels requires only one additional isolated line.

Both opto isolators and pulse transformers could be used to isolate the signals. However, since opto isolators tend to be smaller and less expensive than pulse transformers, they will be the only type of device considered here.

The circuit to be demonstrated is an eight channel data acquisition system with 500V of isolation that uses the LTC1090 and four opto isolators. With the addition of another opto isolator, the circuit can be battery operated, drawing only 50 μ A while taking a reading once every two seconds.

The number of channels can be increased to 16, 24, 32, etc., with one additional opto isolator used to increase the number of channels in multiples of eight. Up to 24 channels can be powered directly by the LT1021.

Circuit Description

The LT1021 powers the analog circuitry and provides an accurate reference. A 1 Ω resistor isolates the reference from power supply transients.

The 4N28s in Figure 1 are very commonly used opto isolators. They provide only 500V of isolation, however. If more isolation is desired, up to 2500V of isolation can be obtained by using 4N25s with no other circuit modifications.

PNP transistors were chosen to drive the opto isolators to optimize signal fall time and clock rate. D_{OUT} of the LTC1090 is transmitted on the falling edge of SCLK. Data is clocked into the processor on the rising edge of SCLK. It is therefore necessary that the falling edge of SCLK have as little delay as possible through the opto isolator. This insures that D_{OUT} can be output by the LTC1090 in time to be captured by the processor on the rising edge of SCLK. NPNs could be used at slower data rates or if burning more current is not objectionable.

The current limiting resistors in the collectors of the opto drivers are chosen with the Current Transfer Ratio (CTR) of the opto isolator in mind. The output transistor of the opto isolator must have enough base current to drive the desired

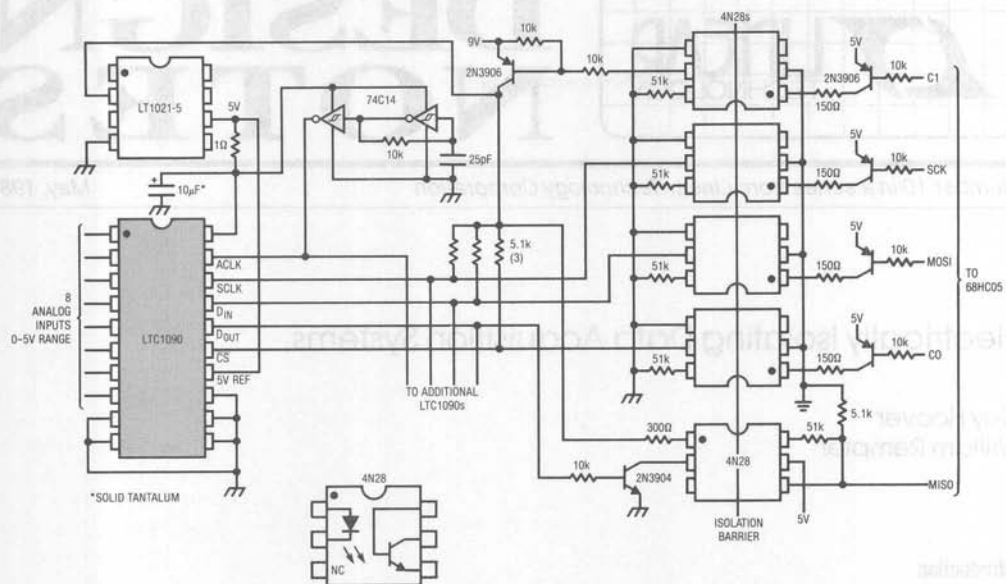

Figure 1. Micropower, 500V Opto Isolated, Multichannel, 10-Bit Data Acquisition System is Accessed Once Every Two Seconds

load. The base resistor on the opto output transistor is there to decrease the turn off time of the opto isolator.

The code written for the Motorola 68HC05 processor is available from Linear Technology. The code powers up the circuit, allows 6.0ms for the 10µF cap to charge to its final value, reads 9 channels in 12ms, and then powers down until the next set of readings is required. Nine channel readings are required because, when the LTC1090 is powered up, a dummy read is necessary to initialize the device. The frequency of the ACLK generated by the 74C14 is not too critical. The software must provide a delay of at least two ACLK cycles between the time \overline{CS} goes low and the first SCLK edge is generated. Another delay of 44 ACLKs is required during the time that \overline{CS} is high between data transfers.

Alternatives

The circuit demonstrated in Figure 1 is capable of transferring serial data at about a 15kHz rate, which is fast enough for many applications. For higher data transfer rates, pulse

transformers from companies such as Sprague or Pulse Engineering, or high speed opto isolators such as Hewlett Packard's HCPL2200 are available which can transmit data at the full 1MHz rate that the LTC1090 is capable of.

Summary

The LTC1090 with its serial architecture is ideally suited for isolation applications. It requires only four isolated lines for eight channels of data and can be expanded by adding only one additional isolated line for each additional eight channels of data required. Possible applications for this and similar circuits are PC-based measurement systems, medical instrumentation and other applications where large common-mode voltages or ground loops exist.

For LTC1090 literature call 800-637-5545. For help with an application call (408) 432-1900, Ext. 361.