

Circuit Special

LIN/LOG CONVERTER

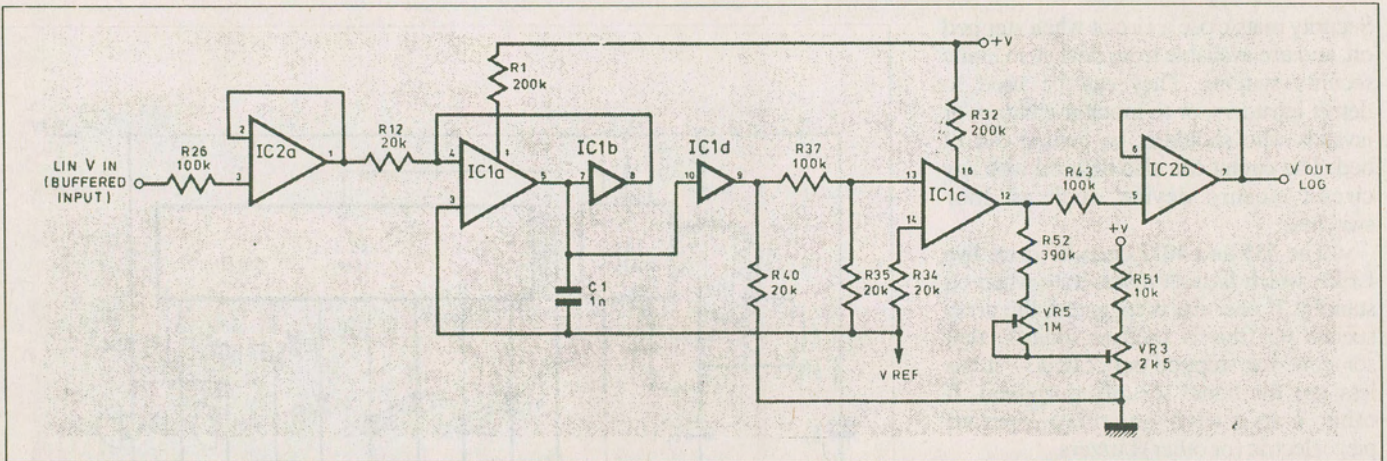

Useful for synthesizers or test gear, this linear-to-logarithmic converter uses the LM 13600 transconductance amplifier (IC1) and any dual low-noise op amp.

To maintain the same equivalent currents on both control nodes of IC1a and 1c, which assists temperature stability, the gain can be varied with trim-

mer VR5 to change the load factor at the output of IC1c. The overall voltage range can be shifted up or down by adjusting trimmer VR3.

RANDOM CLOCK GENERATOR

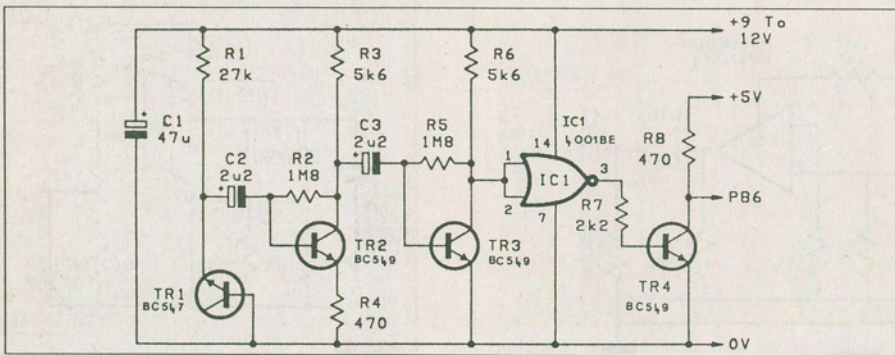

This simple method of producing a random clock signal uses a reverse-biased emitter-base junction that emits noise spikes in much the same way as a zener diode. TR2 and TR3 provide voltage gain for the very low-amplitude spikes (these can be any general-purpose NPN). The 4001BE NOR gate cleans up the signal to CMOS level; if you need a CMOS level, take the signal from pin 3 of the 4001. If you need TTL levels, take the output from the collector of TR4, which can also be any general purpose NPN.

PSEUDO-RANDOM GENERATOR

This circuit generates a pseudo-random sequence of 1s or 0s ("heads" or "tails"). It's based on a 7-bit shift register with the output taken from register G. If the output is high, the *Heads* LED is lit; a low output lights the *Tails* LED. It's slightly biased: since the 0000 state is not allowed, 127 "tosses" results in 64 heads and 63 tails.

IC1a, a 7413 dual Schmitt trigger, debounces the switch contacts and clocks the 74164 register one step. The EX-OR gate is made from four 7400 NAND gates. The other half of the Schmitt trigger, IC1b, is used as an inverter to turn the green LED on when G is low.

Remember that the sequence is only pseudo-random, not truly random. In theory, you could memorize it and be able to predict the next result. But it's highly unlikely that any normal person could

succeed in such a feat of memory and recognize how far along they were in the

sequence. So, *in practice*, this is as random as tossing a coin.

