

Over-Heat Detector



PRADEEP G.

NTC thermistors are often the preferred choice for temperature sensing and control in many applications, primarily because of their small package sizes and attractive price-performance ratios. An NTC thermistor's sensitivity to temperature changes, even in small increments, enables the device to be used in temperature-sensing/control applications. This project for the over-heat detector uses a 10k NTC thermistor.

Circuit and working

The circuit diagram of the over-heat detector is shown in Fig. 1. It is built around a negative temperature co-efficient (NTC1), popular dual op-amp

LM358 (IC1), 12V, 1C/O relay and a few other components.

The dual op-amp LM358 has been used here for sensing temperature variations near the sensor. At room temperature, thermistor resistance is around 10k. When the temperature increases, thermistor's resistance becomes low and output of IC1 at its pin 1 becomes high. As a result, the npn transistor conducts and activates the relay.

For testing the circuit, using potmeter VR1, set reference voltage, say, 2V, at pin 3 of IC1. At normal room temperature, voltage at pin 2 of IC1 remains around 2.4V.

On slightly heating NTC1, voltage at pin 2 of IC1 decreases. When this voltage goes below 2V, output of IC1 at pin 1 goes high and relay RL1

PARTS LIST

Semiconductors:

- IC1 - LM358 dual op-amp
- T1 - BC549 npn transistor
- LED1 - 5mm LED
- D1 - 1N4007 rectifier diode

Resistors (all 1/4-watt, $\pm 5\%$ carbon):

- R1 - 33-kilo-ohm
- R2, R3 - 1-kilo-ohm
- VR1 - 10-kilo-ohm potmeter

Capacitor:

- C1 - 100 μ F, 25V electrolytic

Miscellaneous:

- CON1 - 2-pin connector terminal
- CON2 - 3-pin connector
- S1 - On/off switch
- NTC1 - 10-kilo-ohm NTC thermistor
- RL1 - 12V, 1C/O relay
- RL1 - 12V DC power supply

energises to activate the load connected to it.

Construction and testing

An actual-size, single-side PCB for the over-heat detector is shown in Fig. 2 and its component layout in Fig. 3. Enclose the PCB in a suitable small box in such a way that the thermistor can be placed near the heating area. Since the thermistor is used as a sensor, better fix it at a spot from where it can sense the temperature. Ensure proper wiring of the circuit to avoid any mistake.

Panel-mount the input and output interface and the on/off switch, as required. ●

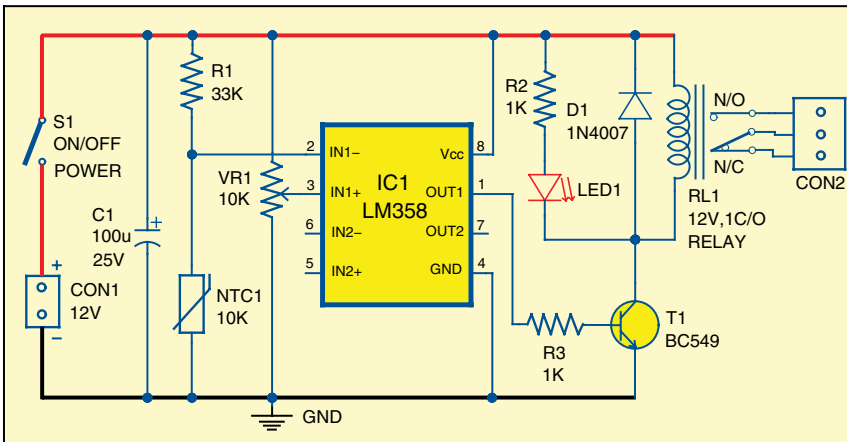

Fig. 1: Circuit of the over-heat detector



Pradeep G. is B.Sc. (Physics) and a regular contributor to international magazines. He is also a small-business owner making school/college projects in South India

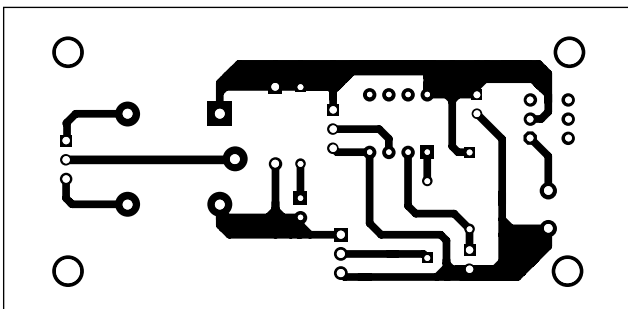

Fig. 2: Actual-size PCB of the over-heat detector

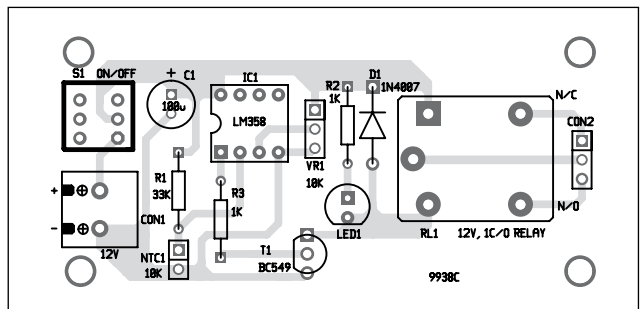

Fig. 3: Component layout of the PCB