

## 1. Overview

The V2153M is a sound enhancement audio processor for professional audio equipments. It regenerates high definitive and nearly real sound. The internal VCA (voltage controlled amplifier) suppresses the boost gain in high band to reduce noise when faint signals are inputted. The V2153M is suitable for mixer and effector for musical instruments, and high-end audio equipment requiring low distortion and wide dynamic range.

Its **features** are:

- Operating Voltage           (±9 to ±18V)
- Low Operating Current       (5.2mA typ.)
- Low Output Noise           (20uVrms typ. at ON)
- Low Distortion               (0.02% typ. at ON)
- Internal ON/OFF Switch
- Bipolar Technology
- Package Outline             SOP20-2

## 2. Block Diagram and Pin Description

### 2.1 Block Diagram

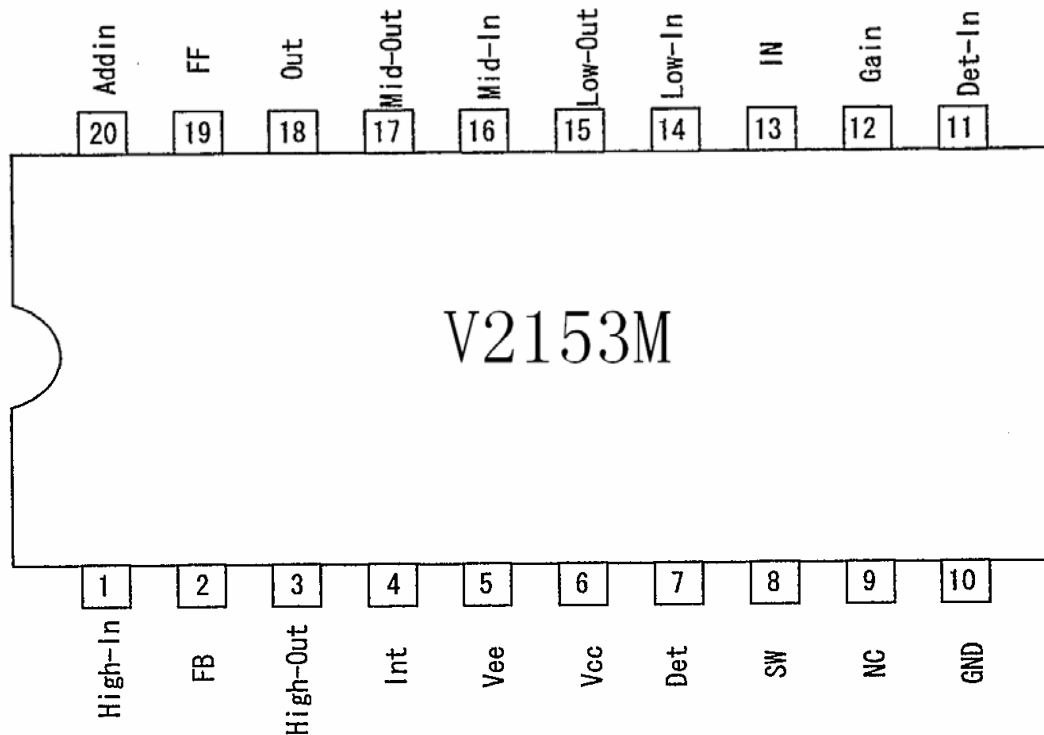

## 2. 2 Pin Description

Pin No.	Symbol	Description	Pin No.	Symbol	Description
1	High-In	High band input	11	Det-In	Detector Input
2	FB	Feedback	12	Gain	Gain
3	High-Out	High band output	13	IN	Input
4	Int	Integral	14	Low-In	Low band input
5	V <sub>EE</sub>	Negative power supply	15	Low-Out	Low band output
6	V <sub>CC</sub>	Positive power supply	16	Mid-In	Mid band input
7	Det	Detector	17	Mid-Out	Mid band output
8	SW	ON/OFF Switch	18	Out	Output
9	NC		19	FF	Feedforward
10	GND	Ground	20	Addin	Add In

## 3. Electrical Characteristics

### 3. 1 Absolute Maximum Ratings

Unless otherwise specified, T<sub>amb</sub>= 25°C

Parameter	Symbol	Value	Unit
Supply Voltage	V <sub>CC</sub>	±20	V
Power Dissipation	P <sub>D</sub>	(DIP) 700 (DMP) 350	W
Operating Temperature	T <sub>amb</sub>	-40 ~ 85	°C
Storage Temperature	T <sub>stg</sub>	-40 ~ 1525	°C

### 3. 2 Electrical Characteristics

T<sub>amb</sub> = 25°C, V<sub>CC</sub> = ±15V, V<sub>IN</sub>=-12dBV/1kHz, R<sub>g</sub>=600Ω, R<sub>L</sub>=100kΩ

Parameter	Symbol	Test Conditions	BEE	Value			Unit
				Min	Typ	Max	
Supply Voltage	V <sub>CC</sub>			±9		±18	V
Supply Current	I <sub>CCO</sub>	No Signal	ON		5.2	8.0	mA
Low Voltage Gain	G <sub>VLF</sub>	f=50Hz	ON	10.0	12.0	14.0	dB
Mid Voltage Gain	G <sub>VHF</sub>	f=700Hz	ON	-2.3	-0.3	0.7	dB
High Voltage Gain 1	G <sub>VHF1</sub>	f=10kHz, Vi=0dBV	ON	10.5	12.0	13.5	dB
High Voltage Gain 2	G <sub>VHF2</sub>	f=10kHz, Vi=-35dBV	ON	7.2	9.2	11.2	dB
High Voltage Gain 3	G <sub>VHF3</sub>	f=10kHz, Vi=-50dBV	ON	-2.0	0.0	2.0	dB
Attack Time	T <sub>ATC</sub>	f=20kHz, -∞~0dBV	ON		100		us
Recovery Time	T <sub>RCY</sub>	F=10kHz, 0dBV~50dBV	ON		500		ms
Maximum Input Voltage	V <sub>IN</sub>	THD=1%	ON	5.0 (1.78)	6.5 (2.11)		dBV(V <sub>rms</sub> )
Maximum Output Voltage	V <sub>O</sub>	THD=1%	ON	17 (7.08)	18.5 (8.41)		dBV(V <sub>rms</sub> )

Output Noise 1	Vno1	Rg=0,DIN Audio	OFF		-100 (10)	-90 (31.6)	dBV( uVrms s)
Output Noise 2	Vno2	Rg=0,DIN Audio	ON		-94 (20)	-84 (63.1)	dBV( uVrms s)
Total Harmonic Distortion 1	THD1	400Hz~30kHzBPF	OFF		0.01	0.05	%
Total Harmonic Distortion 2	THD2	400Hz~30kHzBPF	ON		0.02	0.1	%
SW Control Voltage Threshold	Vth		ON	-2.0	0	2.0	

## 4. Application Circuit

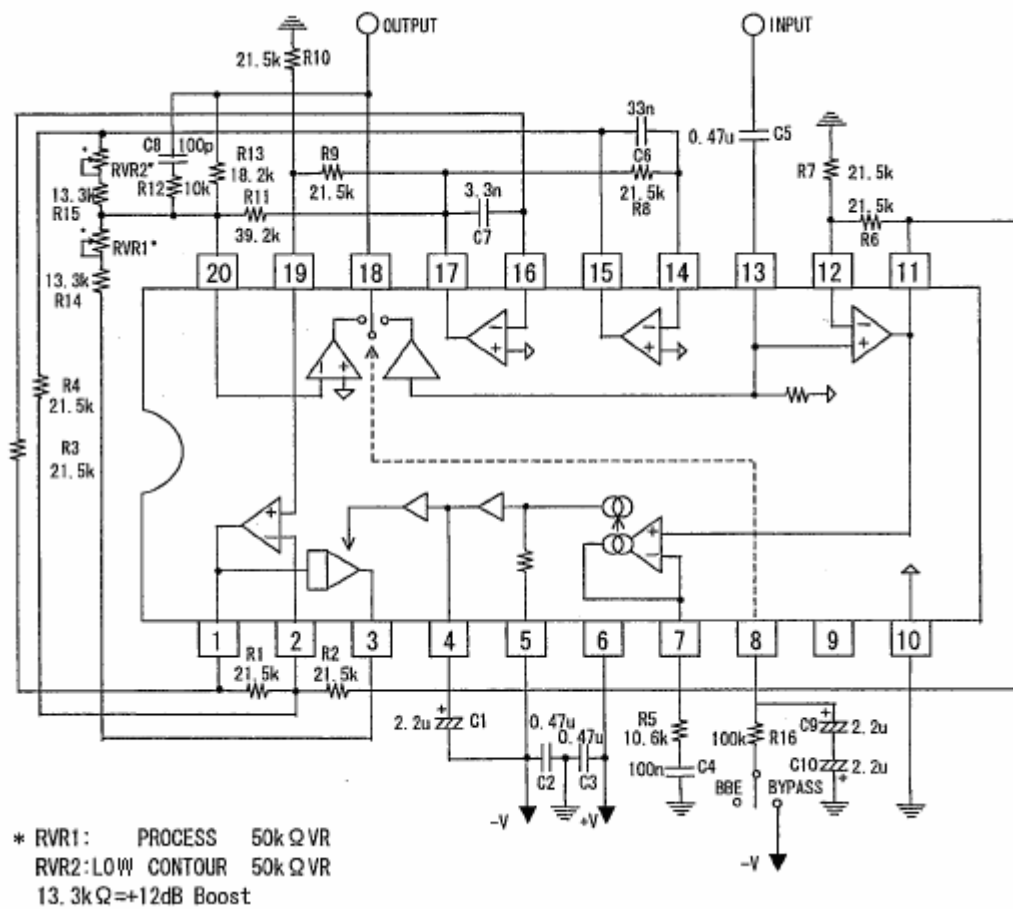

5. Package

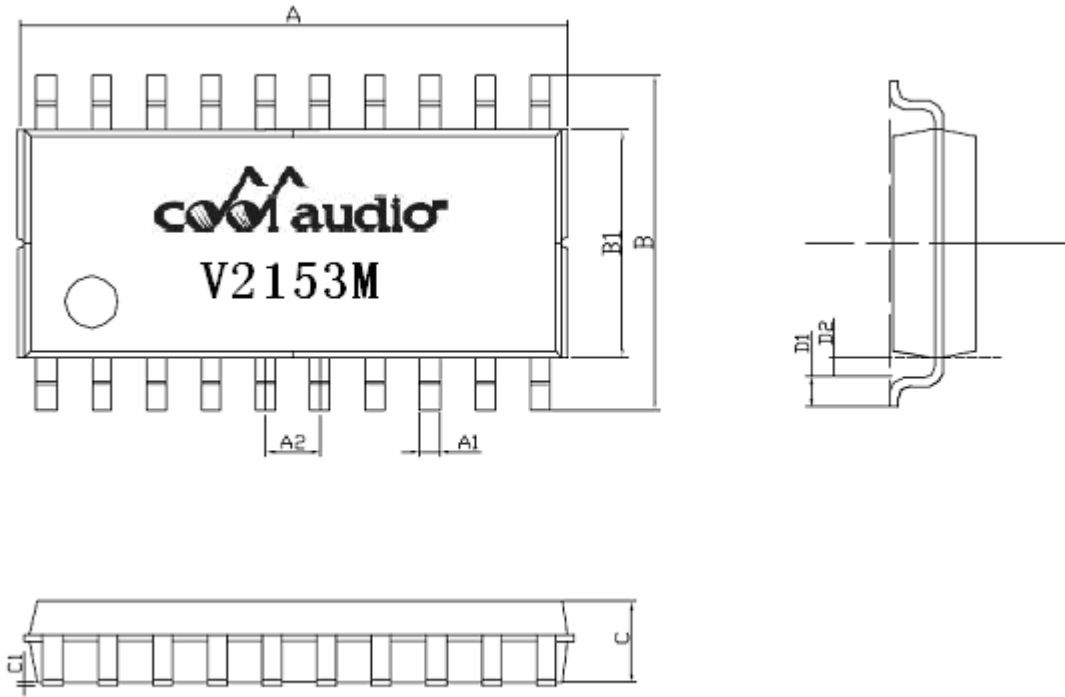

DIMENSION	MILLIMETERS	
	MIN	MAX
A	12.35	12.55
A1	0.40	0.48
A2	1.27	
B	7.60	8.20
B1	5.20	5.40
C	1.80	2.00
C1	0.05	0.20
D1	0.30	0.70
D2	0.65	