



# Table of Contents

**Introduction 3**

**Important Notes on Servicing 3**

**Ordering Replacement Parts 3**

**Block Diagrams 4**

**Start up Procedure 5**

**Protection Modes and Indicators 6**

**Troubleshooting Guide 7**

**Output Transistors Testing and Replacement 8**

**Calibrations and Adjustments 9**

**Parts List 10**

**Updates 11**

**Fuses 13**

**Voltage Change 13**

**Remote Interface Information 14**

**Schematics 15**

The contents of this document as well as the files associated with it contain confidential information that is proprietary to Classé Audio Incorporated and are intended solely for the purpose of servicing product. No part of its contents may be used, copied, disclosed, or conveyed to any party in any manner whatsoever without prior written permission from Classé Audio Incorporated.

# Introduction

**Please read this manual carefully before commencing servicing!  
Only qualified and authorized personnel should attempt to service this product.**



**The lightning flash with arrowhead symbol, within an equilateral triangle, is intended to alert the user to the presence of uninsulated dangerous voltage within the product's enclosure that may be of sufficient magnitude to constitute a risk of electric shock to persons.**



**The exclamation point within an equilateral triangle is intended to alert the user to the presence of important operating and maintenance (servicing) instructions.**

Classé has a global product support network. For product assistance or to order replacement parts please contact your nearest service center always quoting the unit serial number.

## North America

Phone: (978) 664-2870 E-mail: [classe@bwgroupusa.com](mailto:classe@bwgroupusa.com)

## Europe

Phone: 44 (0) 1903 221 700 E-mail: [classe@bwgroup.com](mailto:classe@bwgroup.com)

## Asia

Phone: (852) 2790 8903 E-mail: [classe@bwgroup.hk](mailto:classe@bwgroup.hk)

## Rest of the World

Phone: (514) 636-6384 E-mail: [cservice@classeaudio.com](mailto:cservice@classeaudio.com)

## Important Notes on Servicing

1. ALWAYS observe ESD precautions when handling electronic modules or PCBAs.
2. NEVER exchange boards with a different revision number, unless authorized by Classé.
3. ALWAYS use Classé original replacement parts. The use of generic parts may void the warranty of the unit.

## Ordering Replacement Parts

There may be a delay in processing incomplete requests. Please be sure to include all required information. Remember to quote the serial number of the unit on all replacement part orders and the Classé order number when returning defective parts for credit.

# Block diagrams

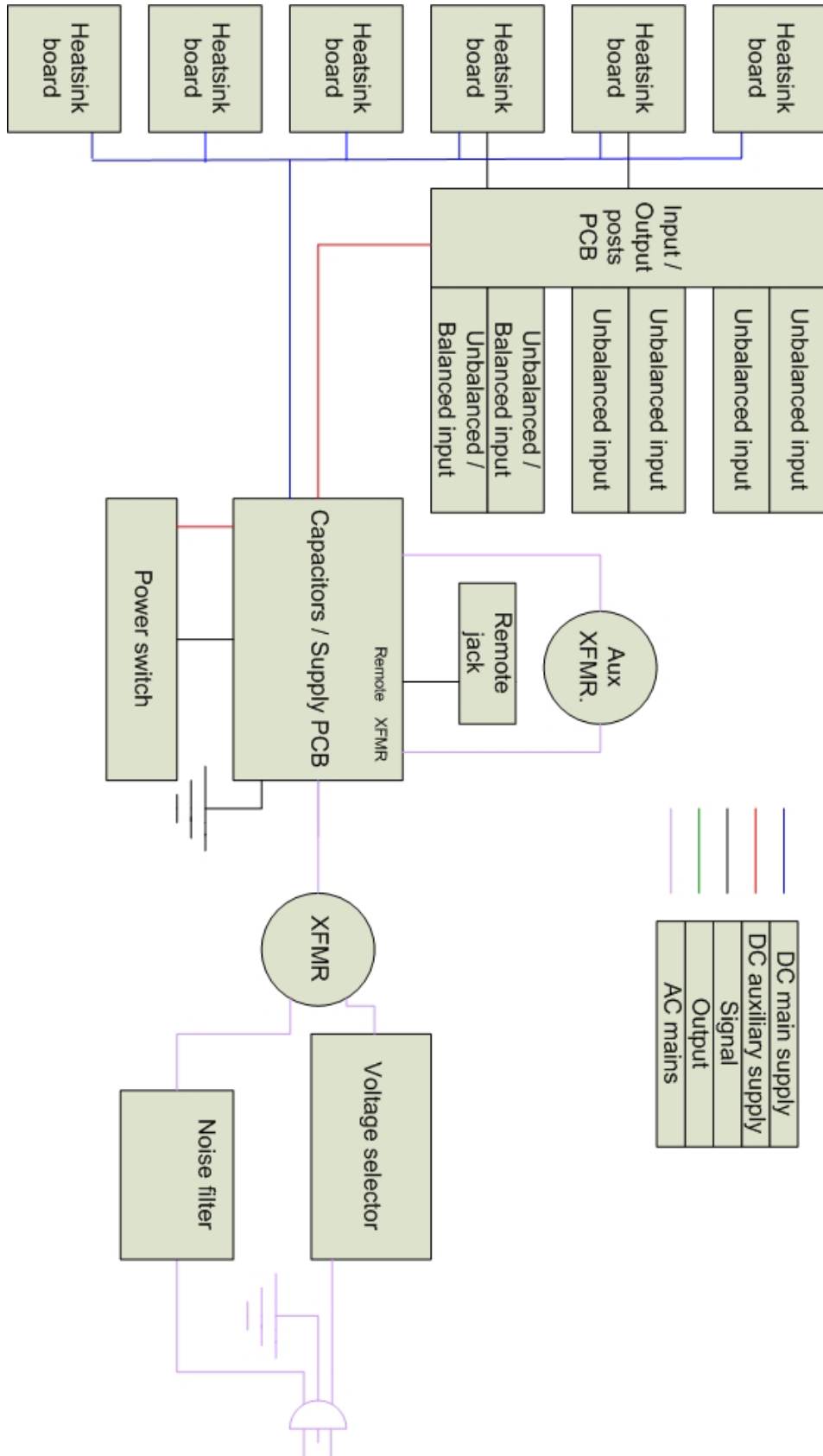

# Start Up Procedure

When receiving a unit, an assiduous visual inspection must be performed. Do not connect the unit without analysing the symptoms reported by the customer and the results of the inspection.

Using the troubleshooting guide, find the problem and proceed to the repair. Once this step is done, follow these steps, known as the start-up procedure, to ensure that everything in the unit is in working condition.

1. Proceed with a post repair visual inspection. Take the time to check if every wire is reconnected properly, every screw is bolted on, no soldering and/or metal residues lying in the unit, every fuse has been replaced, etc.
2. Connect the unit to a variable transformer, setted to 0Vac.
3. Turn the bias trimpot (R22) counter clockwise until a click is heard.
4. Connect the bypass wire to the variable transformer. This bypass is a power cord, modified on the female side in order to bypass the soft start sequence. It is connected to the line tab on power switch / protection PCB.
5. Slowly raise the voltage to 10Vac, and check positive and negative rails and pre-driver supply. Check fuses.
6. If one or more supply are not within specifications, return to the troubleshooting guide.
7. Slowly raise voltage until you hear relays click, this point is around 55Vac. Recheck every supply.
8. If one or more supply are not within specifications, return to the troubleshooting guide.
9. Raise voltage to 120Vac. Recheck every supply
10. If every supply is within specifications, unplug the unit and bypass from the variable transformer. Reconnect only the unit.
11. Report to Calibration and adjustments (section 9) to adjust bias and DC offset. Note that bias can be adjusted to 14mV, and the following tests can be performed before the unit is send to the burn-in bench for a 24 hours warm-up.
12. Connect the unit to a load, and to a source using balanced inputs and single ended inputs, independently.
13. Perform a test with a 200Hz, a 2kHz and a 20kHz tone, both sinus wave and square wave. Check the output with a oscilloscope, on 4 ohms and 8 ohms loads. Take special cares about oscillation and phase correlation between channels.
14. Connect the unit to a small speaker, and short the input. Check for any noise. Perform this step with single ended inputs and balanced inputs, independently.
15. Put the unit on a burn-in bench, and let it sit for 24 hours, then readjust bias. Let the unit on the burn-in bench for another 72 hours.
16. Redo steps 11 to 14 before shipping to the customer.

## Protection Modes and Indicators

The front LED shows the status of the amplifier (ON or OFF). Unlike other Classé amplifiers, when starting up a CAV150, the front LED will not show a flashing pattern, since there is no soft start sequence. The only protection available on a CAV150, besides DC offset protection, consists of rail and mosfet fuses. If there is a fault, one or more fuses will blow, showing a faulty component. The technician will first need to identify and cure the cause of failure (please report to troubleshooting guide). When the cause has been identified, disconnect the unit from the system including the AC power. Remove the top cover and look for damaged or burned components. If no other components than the fuses appear to be damaged, the technician can then replace the broken fuses with the same value and rating (please report to fuses section). The fuses are located on the capacitor board (rail) and on the heatsink board (Mosfet). When replacing fuses, please make sure that the fuse holder are holding the fuses very tightly. A loose fuse holder can translate into distortion on top of the signal.

# Troubleshooting Guide

Symptom	Possible cause
Unit won't turn on	Check connections; Check fuses; Check soft-start circuit; Check relays; Check power supply circuits (positive rail, negative rail, Mosfet supply).
Smoked and/or burned components	Check for short between components and ground; Check output transistors; Check output relays; Check power supply circuits (positive rail, negative rail, Mosfet supply).
Blown fuses	Check for short between fuse and ground; Check power supply circuits (positive rail, negative rail, Mosfet supply).
No output	Check connexions; Check output relays; Check power supply circuits (positive rail, negative rail, Mosfet supply); Check output transistors.
Unit turn into protection	Check for smoked and/or burned components; Check power supply circuits (positive rail, negative rail, Mosfet supply); Check source and load; Check protection circuit; Check sensor wires between sensor PCB and control PCB; Check outputs transistors and Mosfet drivers.
Excessive buzz and/or hum	Check electrical lines; Check for a ground loop in the system.
Oscillation	Check source; Check capacitors on main board; Check 4.7Ω resistor.
Intermittent signal	Check connections; Replace shield wires.

# Output Transistors Testing and Replacement



**PLEASE NOTE THAT THESE TESTS ARE ONLY EFFECTIVE ON BIPOLAR TRANSISTORS. DO NOT PERFORM THESE TESTS ON MOSFET DEVICES, AS THEY ARE LIKELY TO BECOME SHORT DURING THE TEST.**

You should check all pin combinations, as there is a chance that only one side of the transistor is short. When replacing output transistors, the technician should first disconnect both outputs and main board to check if the blown outputs were caused by a faulty component on the amplifier's base. Blown output transistors should be replaced by kits, not individually. These kits contain matched transistors for both rails of one channel. When replacing blown output transistors, you must also replace positive and negative Mosfet drivers and bias transistor. Carefully inspect 4.7Ω resistor and 10Ω soft start resistor, and replace if necessary. Replace any burnt component or board.

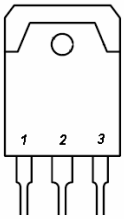

Pins : 1      Base  
         2      Collector  
         3      Emitter

You should have these results, if the transistor is good.

2SC3263 (NPN)

Positive lead	Negative lead	Result
B	C	Conductive
B	E	Conductive
C	B	Infinite
C	E	Infinite
E	B	Infinite
E	C	Infinite

2SA1294 (PNP)

Positive lead	Negative lead	Result
B	C	Infinite
B	E	Infinite
C	B	Conductive
C	E	Infinite
E	B	Conductive
E	C	Infinite



# Calibrations and Adjustments

Bias adjustment:

Note: Bias adjustment should be made without any load connected to the amplifier's output, and no signal connected to the amplifier's input.

1. Connect a multimeter to R4 leads and set the multimeter to mV scale.
2. Turn trimpot R22 counterclockwise until it reaches  $0\Omega$ . A click should be heard.
3. Turn on amplifier, and let it warm up for 15 minutes on idle.
4. Adjust trimpot R22 to get a 14mV reading.
5. Repeat for all channels.
6. Let the amplifier warm up for a 24 hours period with signal and load.
7. Remove signal and load, and reconnect the multimeter.
8. Readjust to 20mV.
9. Repeat step 8 and 9 to all channels.

DC offset:

Note: DC offset adjustment should be made without any load connected to the amplifier's output, and no signal connected to the amplifier's input.

On these units, DC offset can't be adjusted. Measure DC offset using a voltmeter connected to the output posts, scale setted to mV. DC offset should be less than 10mV.

## Parts List

This is not a detailed part list. It is a list of major chassis parts and PCBs. If you need to order a specific part, please contact Classe Audio with the part location, PCB number, and model and serial number of the unit. If you need a complete PCB, please replace the (x) in the Classe part number with the revision number printed on the board.

Parts	Description	Classe part number
B0A1X	Complete PCB, heatsink	B0A1XR(x)
B0A2X	Complete PCB, power switch / protection	B0A2XR(x)
B0A3X	Complete PCB, input / output posts	B0A3XR(x)
B01GX	Complete PCB, filter	B01GXR(x)
B0A4X	Complete PCB, amplifier	B0A4XR(x)
B0A5X	Complete PCB, capacitors / supply	B0A5XR(x)

# Updates

1. On board B0A3X, replace R1, R2, R3, R4, R5 and R6 with Classe part number A211-1004.
2. On board B0A4X (six PCBs), replace R40 and R41 with Classe part number A211-1447
3. On chassis, install PCB filter (noise elimination module) B01GX, using the following instructions.

Noise elimination module:



**EXTRA PRECAUTIONS SHOULD BE TAKEN WHEN REPAIRING, MODIFYING, OR TROUBLESHOOTING IN THE POWER SUPPLY AREA. UNIT MUST BE DISCONNECT FROM MAIN SOURCE AND CAPACITORS MUST BE DISCHARGED USING A 100W INCANDESCENT BULB.**

1. Remove top cover, handles and faceplate (for more information about mechanical disassembly and reassembly, report to section 2, mechanical assembly)
2. Turn the unit upside down, front of the unit facing you
3. Using a pencil, make a mark at 3½" from the back of the unit, 5½" from the ride side. Use a punch to guide the drill bit.
4. Using a 1/8" drill bit, drill a hole at this intersection. Clean the area for any metal residue.
5. Remove two black screws holding the voltage selector PCB
6. Disconnect the wire from N (neutral). The wire should be yellow or clear. Take time to identify each wire in order to reconnect them properly.
7. Disconnect wire from L (live). The wire should be blue or black. Identify this wire.
8. Gently strip off the black shrink tubing covering both wires.
9. Cut N wire about 4 inches (10.2cm) from the edge of the lower portion of the supply PCB
10. Connect N wire to one end of the noise filter board, Classe part number B01GXR01. (Fig. 1)
11. Using the wire supplied with the kit, connect the other end of the noise filter board. (Fig. 1)
12. Fix the board to the chassis, using the screws supplied with the kit.
13. Install the heat shrink tubing supplied on N (new wire) and L wires
14. Reconnect both wires to the voltage selector PCB
15. Clean and spotcheck connections
16. Reassemble and test unit carefully for proper operation.

# Updates

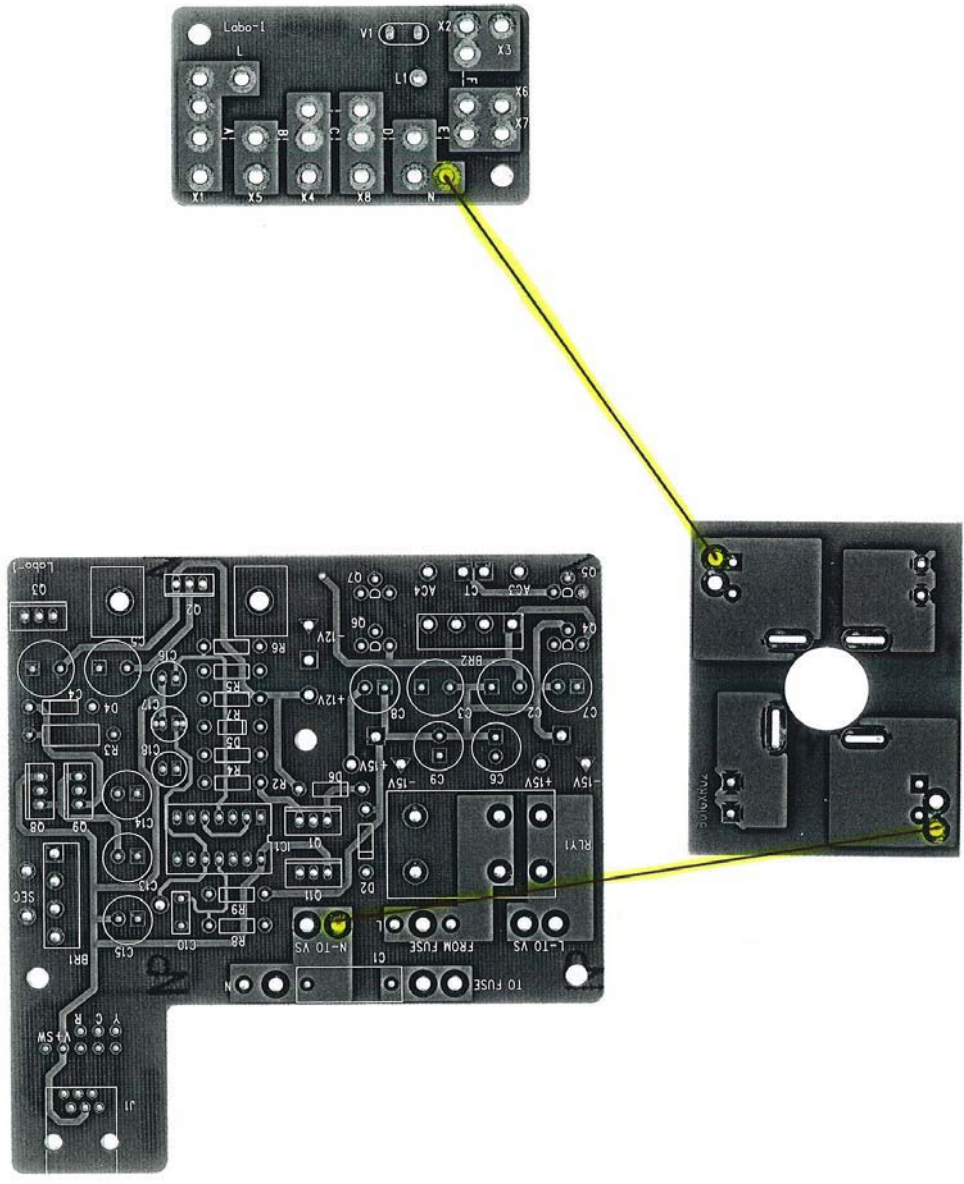

fig. 1

# Fuses



**EXTRA PRECAUTIONS SHOULD BE TAKEN WHEN REPAIRING, MODIFYING, OR TROUBLESHOOTING IN THE POWER SUPPLY AREA. UNIT MUST BE DISCONNECT FROM MAIN SOURCE AND CAPACITORS MUST BE DISCHARGED USING A 100W INCANDESCENT BULB.**



**WHEN REPLACING FUSES, PLEASE MAKE SURE THAT THE FUSE HOLDERS ARE HOLDING THE FUSES VERY TIGHTLY. A LOOSE FUSE HOLDER CAN TRANSLATE INTO DISTORTION ON TOP OF THE SIGNAL.**

Main fuses:

For 100 – 120v units: 8A slo-blo, Classe part number MDL-8A

For 220 – 240v units: 6A slo-blo, Classe part number MDL-6A

The main fuse is located on the Power switch / protection board (B0A2X).

Rail fuses: 5A, Classe part number GDB-5A

The rail fuses are located on top of the Capacitors board (B0A5X).

Mosfet fuses: 0.50A, Classe part number 225.500

The Mosfet fuses are located on the Heatsink boards (B0A1X).

Control board fuse: 0.75A, Classe part number 225.750

The control board fuse is located on the Power switch / protection board (B0A2X).

# Voltage Change



**EXTRA PRECAUTIONS SHOULD BE TAKEN WHEN REPAIRING, MODIFYING, OR TROUBLESHOOTING IN THE POWER SUPPLY AREA. UNIT MUST BE DISCONNECT FROM MAIN SOURCE AND CAPACITORS MUST BE DISCHARGED USING A 100W INCANDESCENT BULB.**

1. Set the jumper position according to the table below.
2. Replace the varistor, according to new line voltage, following Classe's recommendations. If varistor is not available, remove old varistor and leave it empty.

Jumper positions, main transformer

Mains	Jumper 1	Jumper 2	Jumper 3	Varistor
100VAC	A	E	F	221
120VAC	A	C	D	221
220VAC	B	E	-	391 / 441
240VAC	B	D	-	391 / 441

Jumpers, auxiliary transformer

Mains	Position 1	Position 2	Position 3	Position 4	Position 5
100/120VAC	In	Out	Out	Out	In
220/240VAC	Out	Out	In	Out	Out

# Remote Interface Information

The CAV150 can be turned on or off using an simple interface connected to the Remote jack, located at the back of the unit.

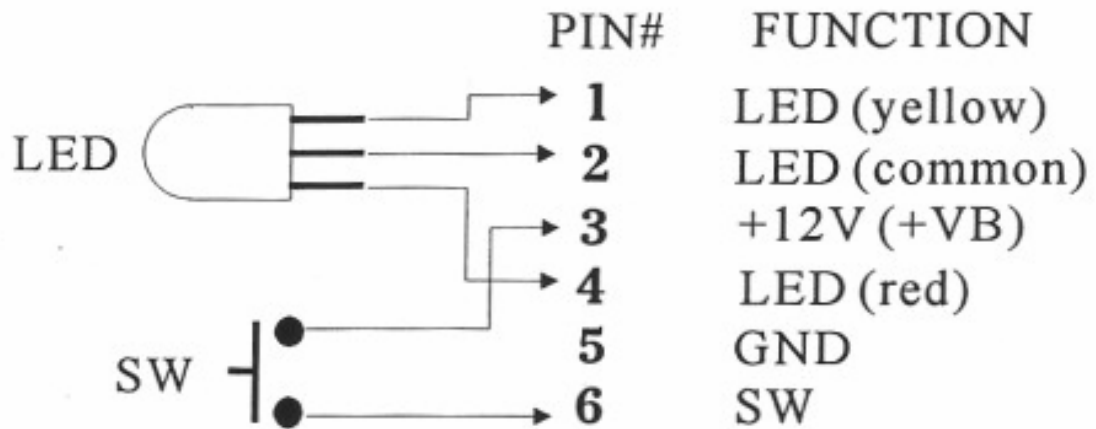
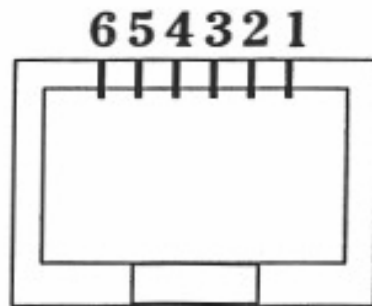

6

5

4

3

2

1

D

D

C

C

B

B

A

A

REVISION RECORD			
LTR	ECO NO:	APPROVED:	DATE:

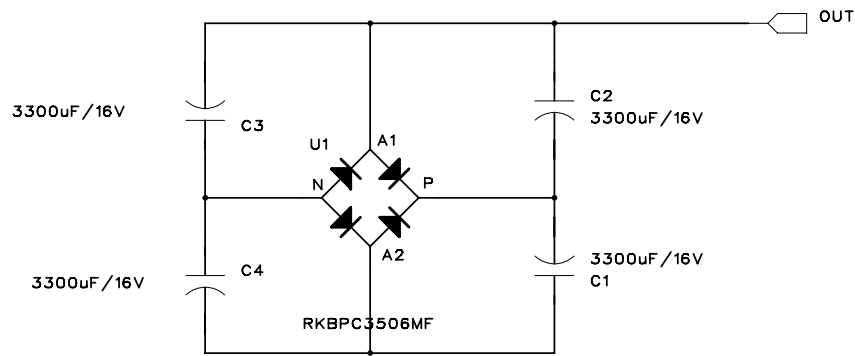

COMPANY:				Classé Audio Inc.				
TITLE:				NOISE FILER				
DRAWN:		DATED:		CODE:	SIZE:	DRAWING NO:		REV:
CHECKED:		DATED:		B01GXR02				
QUALITY CONTROL:		DATED:						
RELEASED:		DATED:		SCALE: JUNE 23, 2000				SHEET: 1 OF 1

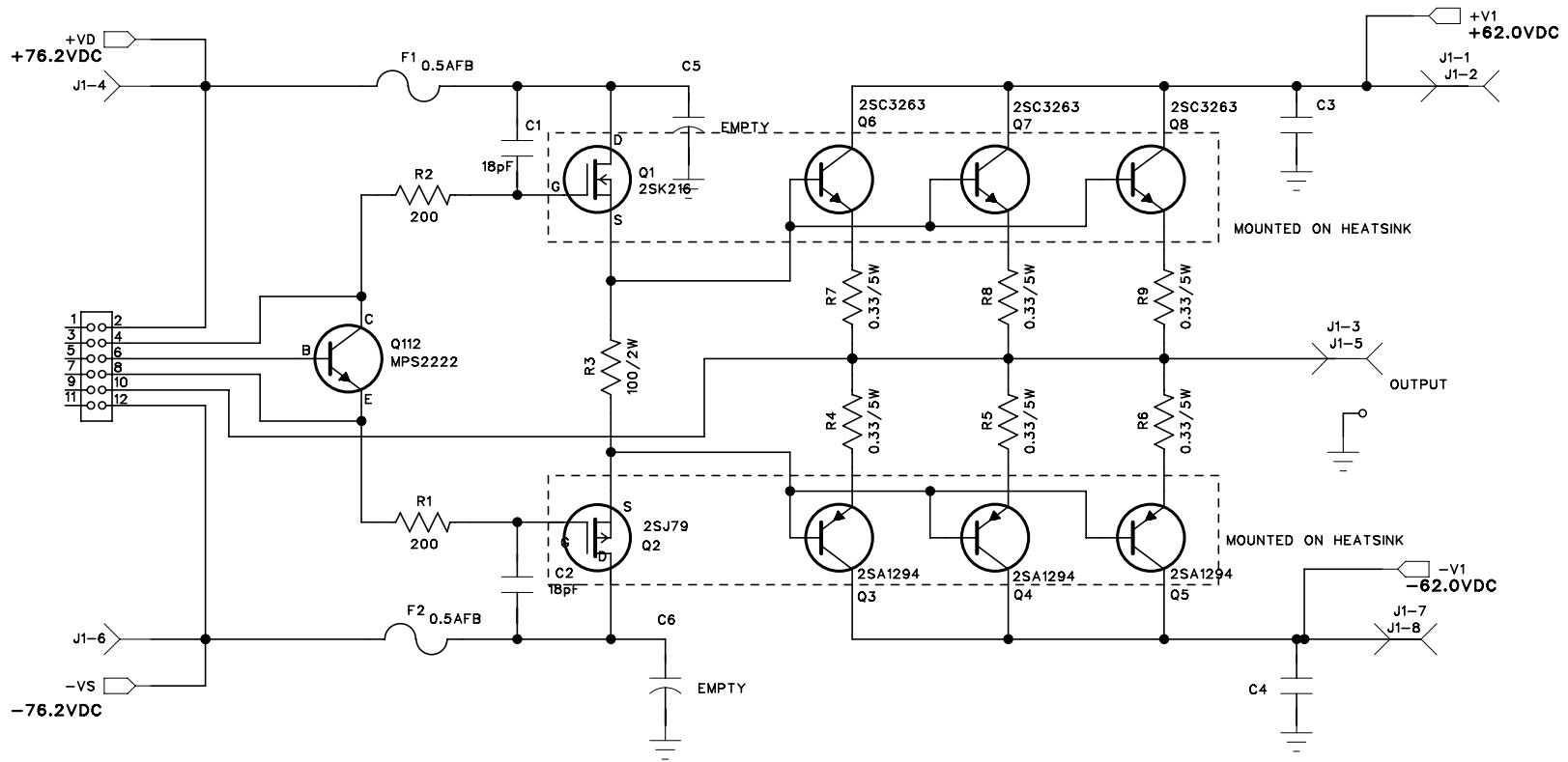

COMPANY:	CLASSE AUDIO INC.		
TITLE:	6-CHANNEL POWER AMPLIFIER		
DESC:	OUTPUT SECTION		
DRAWING NO:	BOA1		
DRAWN:	NVK	DATE:	JUN 01/95
		SHEET:	1 OF 6



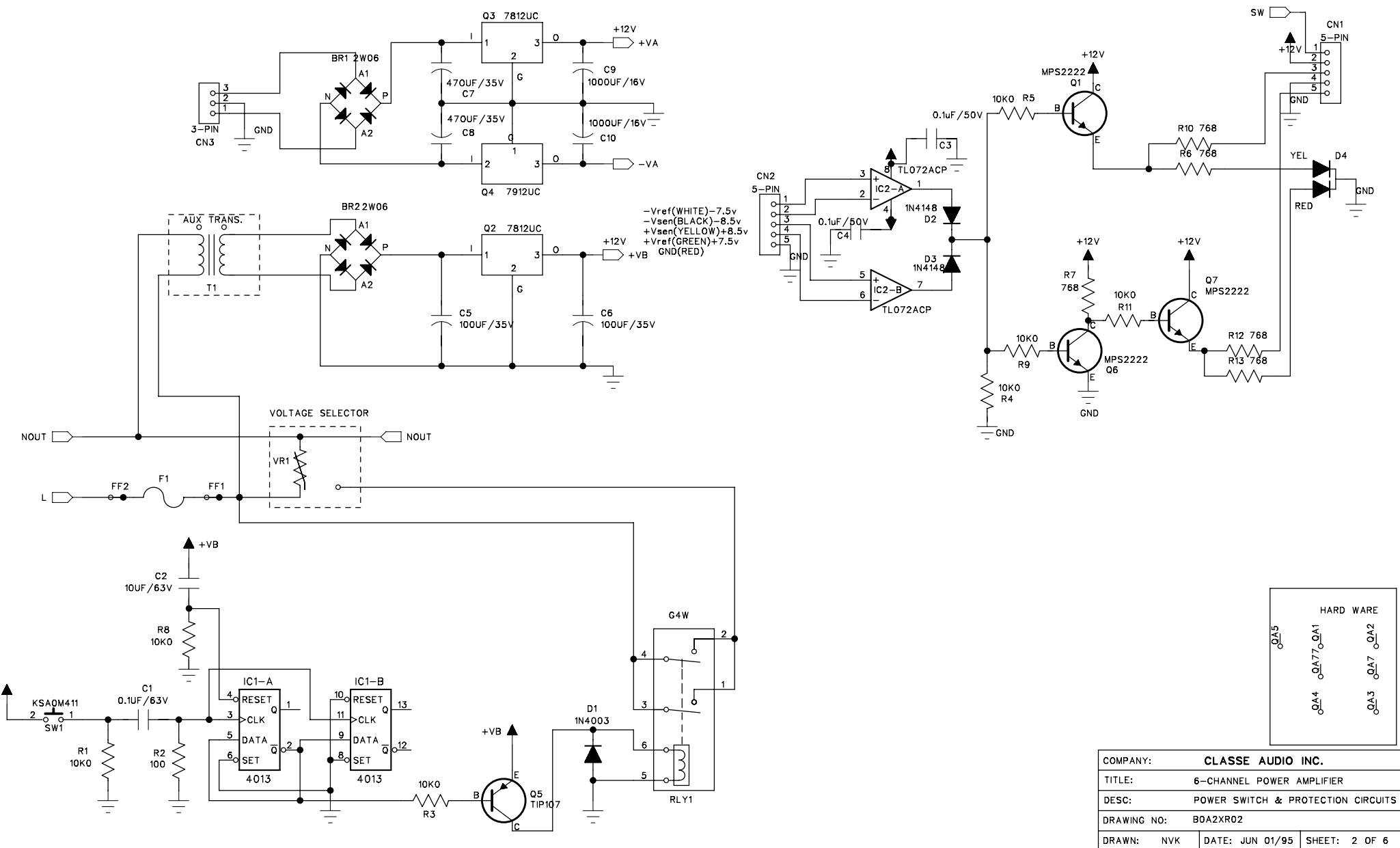

-Vref(WHITE)-7.5v  
 -Vsen(BLACK)-8.5v  
 +Vsen(YELLOW)+8.5v  
 +Vref(GREEN)+7.5v  
 GND(RED)

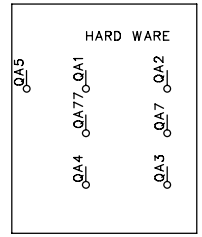

COMPANY: CLASSE AUDIO INC.		
TITLE: 6-CHANNEL POWER AMPLIFIER		
DESC: POWER SWITCH & PROTECTION CIRCUITS		
DRAWING NO: BOA2XR02		
DRAWN: NVK	DATE: JUN 01/95	SHEET: 2 OF 6

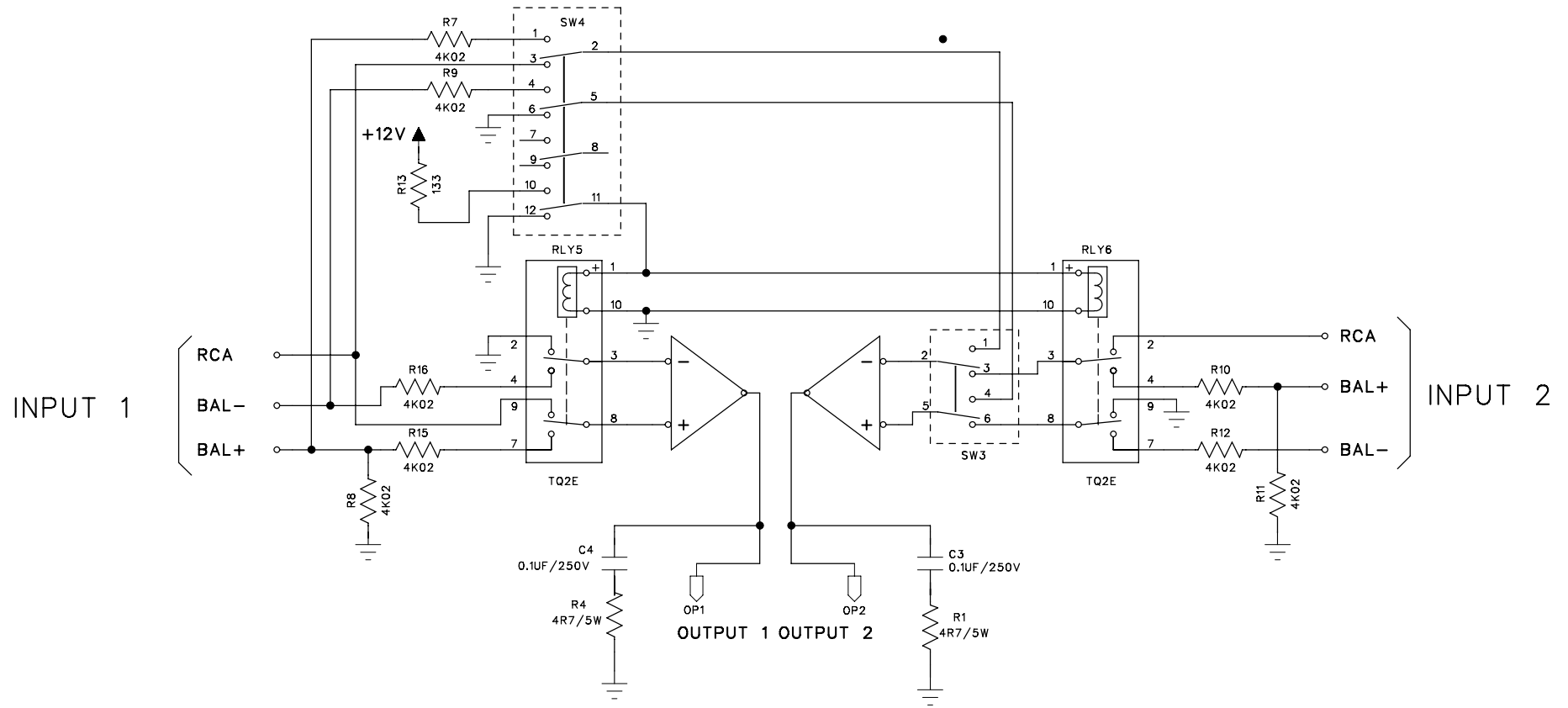

COMPANY:		CLASSE AUDIO INC.	
TITLE:		6-CHANNEL POWER AMPLIFIER	
DESC:		OUTPUT SECTION	
DRAWING NO:		BOA3	
DRAWN:	NVK	DATE:	JUN 01/95
		SHEET:	3 OF 6

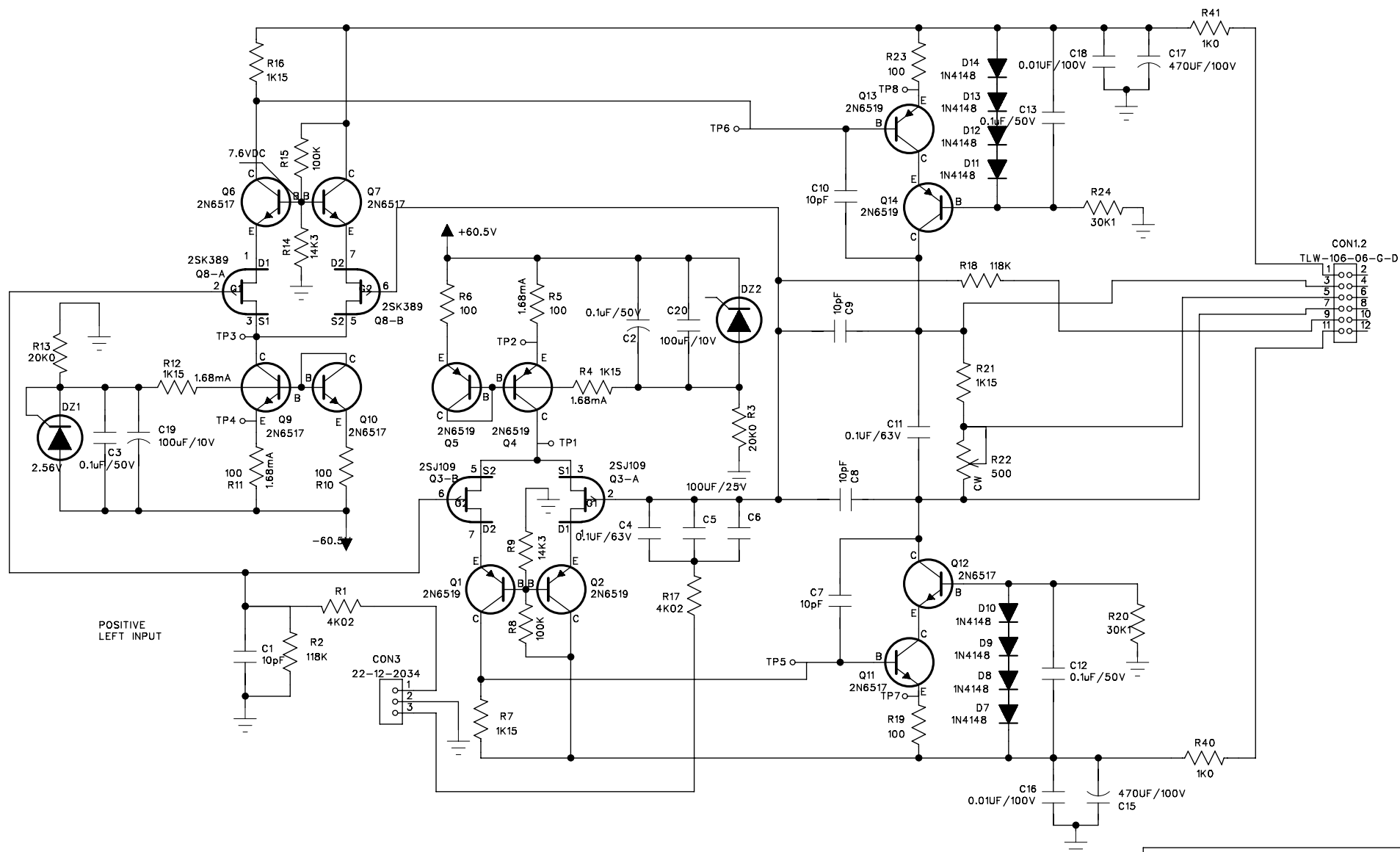

COMPANY:	CLASSE AUDIO INC.		
TITLE:	6-CHANNEL POWER AMPLIFIER (CAV-150)		
DESC:	AMPLIFIER FRONT END SECTION		
DRAWING NO:	BOA4XR02		
DRAWN:	NDN	DATE:	NOV 12/96
		SHEET:	5 OF 6

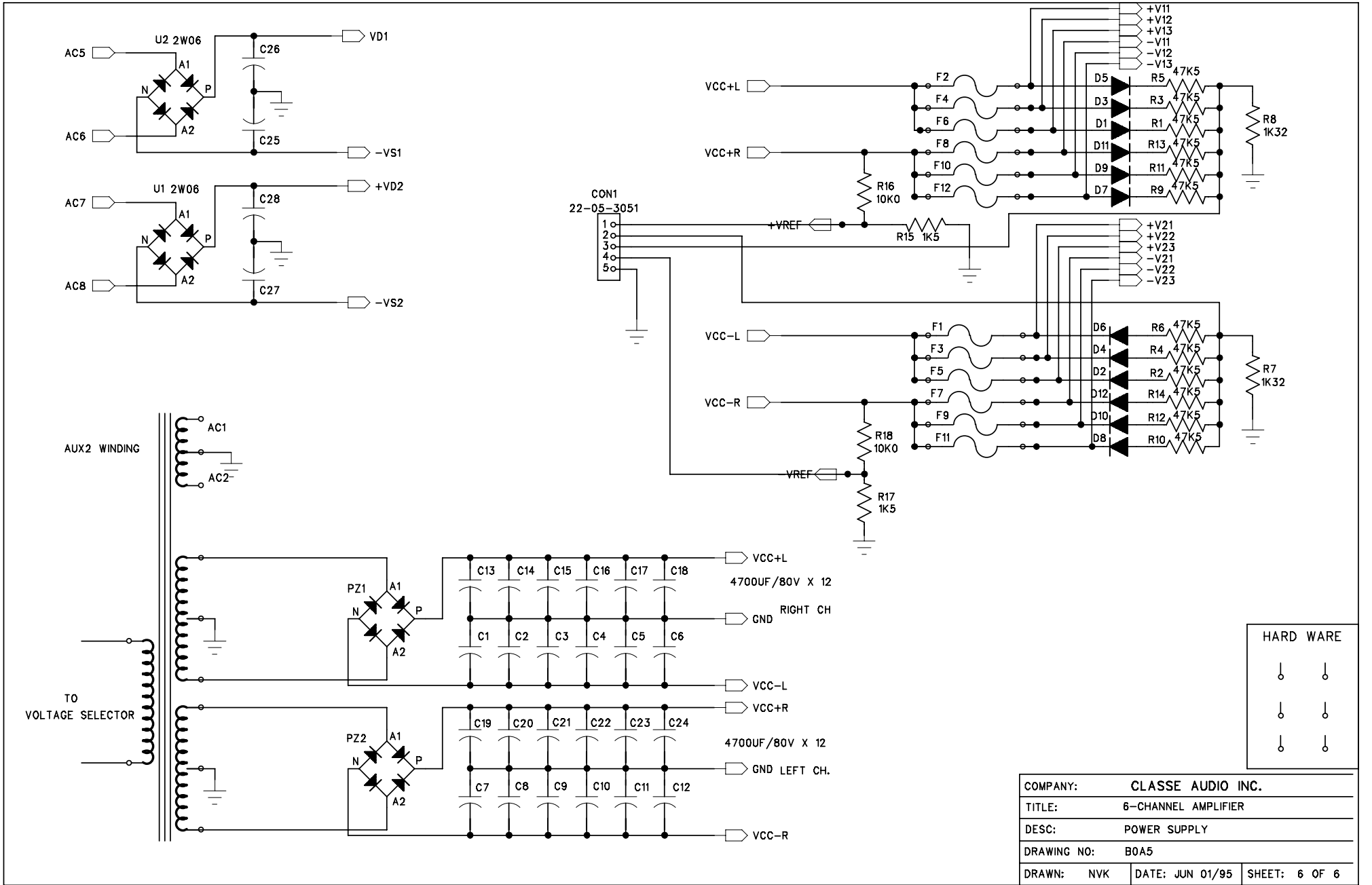

COMPANY:		CLASSE AUDIO INC.	
TITLE:		6-CHANNEL AMPLIFIER	
DESC:		POWER SUPPLY	
DRAWING NO:		BOA5	
DRAWN:	NVK	DATE:	JUN 01/95
		SHEET:	6 OF 6