

# SERVICE MANUAL

---

COMPACT DISC STEREO  
CASSETTE RECEIVER

BASIC TAPE MECHANISM : ZZM-1 YR2NP  
BASIC CD MECHANISM : DA11T3C

---

This Service Manual is the "Revision Publishing" and replaces "Simple Manual"  
(S/M Code No. 09-003-342-2T6).

# SPECIFICATIONS

## GSC MODEL

### Tuner section

Frequency range, antenna — FM: 87.5 - 108.0 MHz Rod antenna,  
MW: 530 - 1,605 kHz Ferrite bar antenna, LW: 150 - 285 kHz Ferrite bar  
antenna

### Deck section

Track format — 4 tracks, 2 channels / Frequency range — Normal tape:  
50 - 12,500 Hz (EIAJ) / Recording system — AC bias / Erasing system  
— Magnet erase / Heads — Recording/playback head (1), Erasure head  
(1)

### CD player section

Disc — Compact disc / Scanning method — Non-contact optical scanner  
(semiconductor laser)

### General

Speaker — 100 mm cone type (2) / Output — Headphones jack (stereo  
mini-jack) / Power output — 2.5 W + 2.5 W (EIAJ 7 ohms, T.H.D. 10%  
DC), 1.9 W + 1.9 W (DIN 1% Rated Power) / Power requirements — DC  
12 V using eight size C (R14) batteries, AC 230 V, 50 Hz / Power  
consumption — 14 W / Dimensions — 420 (W) × 185 (H) × 250 (D) mm /  
Weight — 3.45 kg (excluding batteries)

- Design and specifications are subject to change without notice.

## VSC MODEL

### Tuner section

Frequency range, antenna — FM1: 65.0 - 74.0 MHz Rod antenna,  
FM2: 87.5 - 108.0 MHz Rod antenna, AM: 530 - 1,605 kHz Ferrite bar  
antenna

### Deck section

Track format — 4 tracks, 2 channels / Frequency range — Normal tape:  
50 - 12,500 Hz (EIAJ) / Recording system — AC bias / Erasing system —  
Magnet erase / Heads — Recording/playback head (1), Erasure head (1)

### CD player section

Disc — Compact disc / Scanning method — Non-contact optical scanner  
(semiconductor laser)

### General

Speaker — 100 mm cone type (2) / Output — Headphones jack (stereo  
mini-jack) / Power output — 2.9 W + 2.9 W (DIN MUSIC POWER), 2.5 W  
+ 2.5 W (EIAJ 7 ohms, T.H.D. 10% DC), 1.9 W + 1.9 W (DIN 1% Rated  
Power) / Power requirements — DC 12 V using eight size C (R14)  
batteries, AC 230 V, 50 Hz / Power consumption — 14 W / Dimensions  
— 420 (W) × 185 (H) × 250 (D) mm / Weight — 3.45 kg (excluding  
batteries)

- Design and specifications are subject to change without notice.

## ACCESSORIES/PACKAGE LIST

DESCRIPTIONで判断できない物は "REFERENCE NAME LIST" を参照してください。  
If can't understand for Description please kindly refer to "REFERENCE NAME LIST".

REF. NO	PART NO.	KANRI NO.	DESCRIPTION
	1 8A-CDA-904-010		IB,G(E)FM<GSC>
	1 8A-CDA-907-010		IB,V(ER)FM<VSC>
▲	2 87-050-076-010		AC CORD SET ASSY,E<VSC>
▲	2 87-A80-144-010		AC CORD SET ASSY,G BLK<GSC>

## PROTECTION OF EYES FROM LASER BEAM DURING SERVICING

This set employs laser. Therefore, be sure to follow carefully the instructions below when servicing.

### WARNING!

WHEN SERVICING, DO NOT APPROACH THE LASER EXIT WITH THE EYE TOO CLOSELY. IN CASE IT IS NECESSARY TO CONFIRM LASER BEAM EMISSION. BE SURE TO OBSERVE FROM A DISTANCE OF MORE THAN 30cm FROM THE SURFACE OF THE OBJECTIVE LENS ON THE OPTICAL PICK-UP BLOCK.

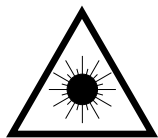

- Caution: Invisible laser radiation when open and interlocks defeated avoid exposure to beam.
- Advarsel: Usynlig laserstråling ved åbning, når sikkerhedsafbrydere er ude af funktion. Undgå udsættelse for stråling.

### VAROITUS!

Laiteen Käyttäminen muulla kuin tässä käyttöohjeessa mainitulla tavalla saattaa altistaa käyttäjän turvallisuusluokan 1 ylittävälle näkymättömälle lasersäteilylle.

### WARNING!

Om apparaten används på annat sätt än vad som specificeras i denna bruksanvisning, kan användaren utsättas för osynlig laserstråling, som överskrider gränsen för laserklass 1.

### CAUTION

Use of controls or adjustments or performance of procedures other than those specified herein may result in hazardous radiation exposure.

### ATTENTION

L'utilisation de commandes, réglages ou procédures autres que ceux spécifiés peut entraîner une dangereuse exposition aux radiations.

### ADVARSEL!

Usynlig laserstråling ved åbning, når sikkerhedsafbrydere er ude af funktion. Undgå udsættelse for stråling.

This Compact Disc player is classified as a CLASS 1 LASER product.

The CLASS 1 LASER PRODUCT label is located on the rear exterior.

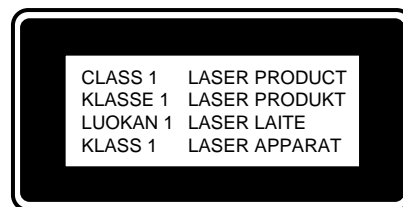

## Precaution to replace Optical block (SF-P101NR)

Body or clothes electrostatic potential could ruin laser diode in the optical block. Be sure ground body and workbench, and use care the clothes do not touch the diode.

- 1) After the connection, remove solder shown in the right figure.

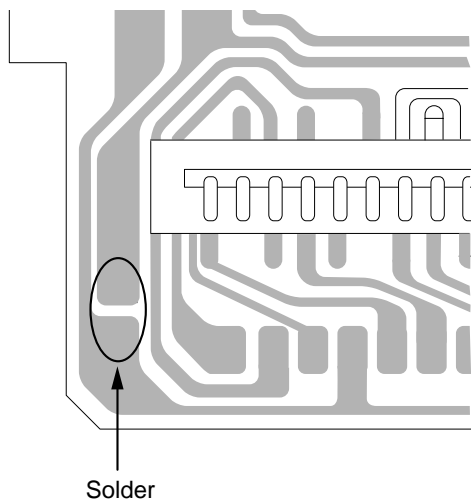

PICK UP ASSY  
SF-P101NR

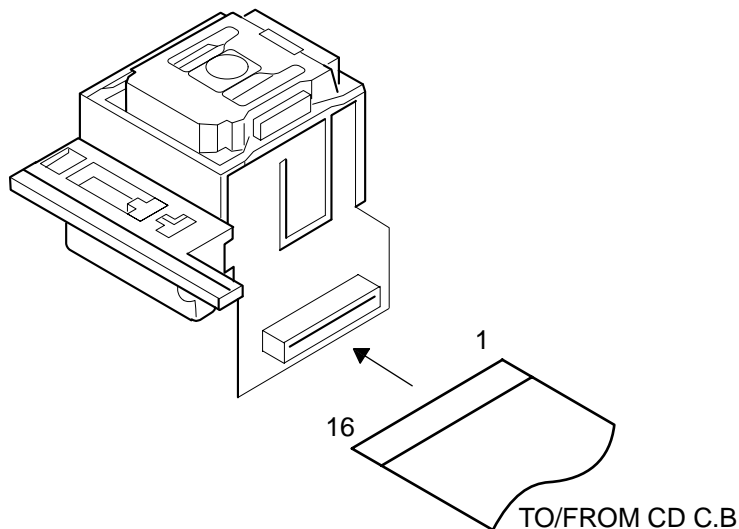

# ELECTRICAL MAIN PARTS LIST

DESCRIPTIONで判断できない物は "REFERENCE NAME LIST" を参照してください。  
 If can't understand for Description please kindly refer to "REFERENCE NAME LIST".

REF.NO	PART.NO.	KANRI NO.	DESCRIPTION	REF.NO	PART.NO.	KANRI NO.	DESCRIPTION
IC				C816	87-010-180-080		C-CER 1500P
	87-A20-955-010	IC,LA1828		C817	87-010-180-080		C-CER 1500P
	87-A21-064-010	IC,LA4227		C821	87-010-401-080		CAP, ELECT 1-50V
	87-A21-443-040	C-IC,M62495AFP		C822	87-010-401-080		CAP, ELECT 1-50V
	87-A20-446-010	C-IC,LA9241ML		C829	87-010-178-080		CHIP CAP 1000P
	87-A20-459-010	C-IC,LC78622ED		C830	87-010-178-080		CHIP CAP 1000P
	87-A20-856-010	IC,BA6898S		C833	87-018-195-080		CAP, CER 1200P-16V
	8A-CD9-610-010	C-IC,LC865516A-5P16		C834	87-010-248-080		CAP, ELECT 220-10V
	87-A21-607-010	IC,NJM14558LD		C843	87-010-197-080		CAP, CHIP 0.01 DM
				C844	87-018-124-080		CAP, CER 270P-50V
TRANSISTOR				C845	87-010-178-080		CHIP CAP 1000P
	89-327-143-080	TR,2SC2714 (0.1W)		C846	87-010-263-080		CAP, ELECT 100-10V
	87-026-447-080	TR,2SC1740S R		C851	87-010-186-080		CAP,CHIP 4700P
	87-026-463-080	TR,2SA933S (0.3W)		C852	87-010-178-080		CHIP CAP 1000P
	87-A30-288-040	C-TR,DTC114YKA		C853	87-A11-132-080		CAP,TC U 0.01-50 K B
	89-318-154-080	TR,2SC1815 (0.4W)		CN201	87-099-018-010		CONN,16P
	89-112-965-080	TR,2SA1296 (0.75W)		CN801	87-A60-110-010		CONN,4P V S2M-4W
	87-026-291-080	TR,DTC124XS		CNA302	8A-CDA-629-010		CONN ASSY,6P MA-TU
	89-213-702-010	TR,2SB1370 (1.8W)		L801	87-007-342-010		COIL,OSC 85K BIAS
	87-026-462-080	TR,2SC1740 S(RS 0.3W)		SW801	8Z-CD9-609-010		SW,SL 1-6-2 PS62D01
	89-109-332-380	TR,2SA933RS		CD C.B			
	89-113-187-080	TR,2SA1318TU		C30	87-010-260-080		CAP, ELECT 47-25V
	87-A30-436-040	C-TR,DTC144TKA		C251	87-010-404-080		CAP, ELECT 4.7-50V
	89-317-403-080	TR,2SC1740S		C261	87-010-402-080		CAP, ELECT 2.2-50V
	87-A30-287-040	C-TR,DTC114TKA		C262	87-010-402-080		CAP, ELECT 2.2-50V
	87-026-464-080	TR,DTC114TS (0.3W)		C263	87-010-178-080		CHIP CAP 1000P
DIODE				C264	87-010-178-080		CHIP CAP 1000P
	87-020-465-080	DIODE,1SS133 (110MA)		C265	87-010-263-080		CAP, ELECT 100-10V
	87-A40-916-040	C-VARI-CAP,HVC202A		C266	87-010-263-080		CAP, ELECT 100-10V
	87-A40-650-080	ZENER,MTZJ6.8A		C267	87-010-112-080		CAP, ELECT 100-16V
	87-A40-912-040	C-DIODE,HSC277B-TRF<VSC>		C268	87-010-112-080		CAP, ELECT 100-16V
	87-070-345-080	DIODE,1N4148		C271	87-010-237-080		CAP, ELECT 1000-16V
	87-A40-648-080	ZENER,MTZJ8.2A		C272	87-010-237-080		CAP, ELECT 1000-16V
	87-A40-234-080	ZENER,MTZJ5.6A		C278	87-010-405-080		CAP, ELECT 10-50V
	87-017-978-080	DIODE,1N4003		C279	87-010-385-080		CAP, ELECT 220-25V
	87-017-932-080	ZENER,MTJ6.2B		△C301	87-016-495-000		CAP,E 3300-25 M SMG
	87-A40-465-010	DIODE,FR202		C306	87-010-404-080		CAP, ELECT 4.7-50V
MAIN C.B				C307	87-010-401-080		CAP, ELECT 1-50V
C211	87-A11-177-080	C-CAP,S 0.15-16 K B		C308	87-010-221-080		CAP, ELECT 470-10V
C212	87-A11-177-080	C-CAP,S 0.15-16 K B		C311	87-010-374-080		CAP, ELECT 47-10V
C215	87-016-460-080	C-CAP,S 0.22-16 B		C312	87-010-385-080		CAP, ELECT 220-25V
C216	87-016-460-080	C-CAP,S 0.22-16 B		C321	87-010-197-080		CAP, CHIP 0.01 DM
C231	87-010-213-080	C-CAP,S 0.015-50 B		C322	87-010-263-080		CAP, ELECT 100-10V
C232	87-010-213-080	C-CAP,S 0.015-50 B		C325	87-010-405-080		CAP, ELECT 10-50V
C233	87-A10-201-080	C-CAP,S0.33-16 KB		C401	87-010-403-080		CAP, ELECT 3.3-50V
C234	87-A10-201-080	C-CAP,S0.33-16 KB		C402	87-010-197-080		CAP, CHIP 0.01 DM
C235	87-016-669-080	C-CAP,S 0.1-25 K B		C403	87-010-263-080		CAP, ELECT 100-10V
C236	87-016-669-080	C-CAP,S 0.1-25 K B		C404	87-010-248-080		CAP, ELECT 220-10V
C237	87-010-371-080	CAP, ELECT 470-6.3V		C405	87-010-197-080		CAP, CHIP 0.01 DM
C239	87-010-197-080	CAP, CHIP 0.01 DM		C406	87-010-374-080		CAP, ELECT 47-10V
C240	87-010-197-080	CAP, CHIP 0.01 DM		C407	87-010-178-080		CHIP CAP 1000P
C247	87-010-401-080	CAP, ELECT 1-50V		C408	87-010-198-080		CAP, CHIP 0.022
C248	87-010-401-080	CAP, ELECT 1-50V		C409	87-010-248-080		CAP, ELECT 220-10V
C310	87-010-248-080	CAP, ELECT 220-10V		C410	87-010-263-080		CAP, ELECT 100-10V
C316	87-010-263-080	CAP, ELECT 100-10V		C411	87-A11-177-080		C-CAP,S 0.15-16 K B
C317	87-015-819-080	CAPACITOR,0.01		C412	87-010-401-080		CAP, ELECT 1-50V
C801	87-010-248-080	CAP, ELECT 220-10V		C413	87-016-369-080		C-CAP,S 0.033-25 B K
C805	87-012-365-080	C-CAP,S 0.027-25VBK		C414	87-010-405-080		CAP, ELECT 10-50V
C806	87-012-365-080	C-CAP,S 0.027-25VBK		C416	87-010-545-080		CAP, ELECT 0.22-50V
C807	87-010-405-080	CAP, ELECT 10-50V		C417	87-012-157-080		C-CAP,S 330P-50 CH
C808	87-010-405-080	CAP, ELECT 10-50V		C418	87-010-213-080		C-CAP,S 0.015-50 B
C809	87-010-401-080	CAP, ELECT 1-50V		C419	87-A11-608-080		C-CAP,S 0.33-25 K B
C810	87-010-401-080	CAP, ELECT 1-50V		C420	87-016-369-080		C-CAP,S 0.033-25 B K
C811	87-010-178-080	CHIP CAP 1000P		C421	87-A11-177-080		C-CAP,S 0.15-16 K B
C812	87-010-178-080	CHIP CAP 1000P		C422	87-010-184-080		CHIP CAPACITOR 3300P(K)
				C423	87-010-992-080		C-CAP,S 0.047-25 B
				C425	87-010-176-080		C-CAP,S 680P-50 SL
				C426	87-A11-608-080		C-CAP,S 0.33-25 K B

REF. NO	PART NO.	KANRI NO.	DESCRIPTION	REF. NO	PART NO.	KANRI NO.	DESCRIPTION
C428	87-010-197-080		CAP, CHIP 0.01 DM	FRONT C.B			
C429	87-010-186-080		CAP,CHIP 4700P	C601	87-010-313-080		CAP, CHIP 18P
C430	87-012-156-080		C-CAP,S 220P-50 CH	C602	87-010-315-080		C-CAP,S 27P-50 CH
C431	87-010-545-080		CAP, ELECT 0.22-50V	C603	87-010-319-080		C-CAP,S 56P-50 CH
C432	87-010-374-080		CAP, ELECT 47-10V	C604	87-010-317-010		CHIP CAP,S 39P CH
C433	87-010-401-080		CAP, ELECT 1-50V	C605	87-010-264-040		CAP,E 100-10 5L
C434	87-010-184-080		CHIP CAPACITOR 3300P(K)	C606	87-012-368-080		C-CAP,S 0.1-50 F
C435	87-010-197-080		CAP, CHIP 0.01 DM	C607	87-015-779-010		CHIP CAPACITOR, 0.01
C436	87-010-374-080		CAP, ELECT 47-10V	C608	87-010-415-080		CAP ELE SRE 10-50V
C437	87-010-404-080		CAP, ELECT 4.7-50V	C609	87-010-493-080		CAP,E 0.47-50 GAS
C438	87-016-669-080		C-CAP,S 0.1-25 K B	C611	87-A10-189-040		CAP,E 220-10
C439	87-010-178-080		CHIP CAP 1000P	C613	87-012-368-080		C-CAP,S 0.1-50 F
C440	87-010-145-080		C-CAP,S 1P-50 CH	C614	87-010-312-080		C-CAP,S 15P-50 CH
C441	87-010-197-080		CAP, CHIP 0.01 DM	C627	87-015-779-010		CHIP CAPACITOR, 0.01
C442	87-010-313-080		CAP, CHIP 18P	C628	87-015-779-010		CHIP CAPACITOR, 0.01
C445	87-012-368-080		C-CAP,S 0.1-50 F	C629	87-015-779-010		CHIP CAPACITOR, 0.01
C446	87-012-368-080		C-CAP,S 0.1-50 F	C630	87-010-264-040		CAP,E 100-10 5L
C447	87-012-368-080		C-CAP,S 0.1-50 F	C631	87-015-779-010		CHIP CAPACITOR, 0.01
C448	87-010-315-080		C-CAP,S 27P-50 CH	CN601	87-099-757-010		CONN,16P 9604S F
C450	87-012-140-080		CAP 470P	CN602	87-A60-079-010		CONN,08P H 9604S-08F
C451	87-012-156-080		C-CAP,S 220P-50 CH	CNA604	8A-CDA-623-010		CONN ASSY,7P KEY
C455	87-010-247-080		CAP, ELECT 100-50V	JW603	87-008-372-080		FILTER, EMI BL OIRNI
C457	87-010-312-080		C-CAP,S 15P-50 CH	JW605	87-003-097-080		COIL,1UH
C458	87-010-312-080		C-CAP,S 15P-50 CH	JW606	87-003-097-080		COIL,1UH
C459	87-010-263-080		CAP, ELECT 100-10V	JW608	87-003-097-080		COIL,1UH
C460	87-015-819-080		CAPACITOR,0.01	JW627	87-008-372-080		FILTER, EMI BL OIRNI
C461	87-010-197-080		CAP, CHIP 0.01 DM	JW633	87-003-098-080		COIL,2.2UH
C462	87-010-248-080		CAP, ELECT 220-10V	L601	87-003-098-080		COIL,2.2UH
C463	87-010-197-080		CAP, CHIP 0.01 DM	LED611	87-CD8-616-010		LED,SA36-11 HWA-11.0
C465	87-010-404-080		CAP, ELECT 4.7-50V	S601	87-A91-704-080		SW,TACT EVQ 214 05R
C466	87-012-368-080		C-CAP,S 0.1-50 F	S602	87-A91-704-080		SW,TACT EVQ 214 05R
C467	87-010-263-080		CAP, ELECT 100-10V	S603	87-A91-704-080		SW,TACT EVQ 214 05R
C469	87-012-154-080		C-CAP,S 150P-50 CH	S604	87-A91-704-080		SW,TACT EVQ 214 05R
C471	87-015-785-080		CHIP CAPACITOR, 0.1FZ-25Z	S605	87-A91-704-080		SW,TACT EVQ 214 05R
C472	87-015-785-080		CHIP CAPACITOR, 0.1FZ-25Z	S611	87-A91-704-080		SW,TACT EVQ 214 05R
C473	87-015-785-080		CHIP CAPACITOR, 0.1FZ-25Z	X601	87-030-273-010		VIB,XTAL 32.768K5PPM
C474	87-015-785-080		CHIP CAPACITOR, 0.1FZ-25Z	X602	87-030-376-080		VIB,CER CSA5.76MG200
C475	87-010-197-080		CAP, CHIP 0.01 DM	TUNER C.B			
C476	87-010-236-080		CAP,E 1000-10 SME	C1	87-010-314-080		C-CAP,S 22P-50V<GSC>
C477	87-010-197-080		CAP, CHIP 0.01 DM	C1	87-010-313-080		CAP, CHIP 18P<VSC>
C478	87-010-263-080		CAP, ELECT 100-10V	C2	87-010-316-080		C-CAP,S 33P-50 CH
C479	87-010-197-080		CAP, CHIP 0.01 DM	C3	87-010-314-080		C-CAP,S 22P-50V<GSC>
C480	87-010-221-080		CAP, ELECT 470-10V	C3	87-010-313-080		CAP, CHIP 18P<VSC>
C481	87-010-405-080		CAP, ELECT 10-50V	C4	87-010-148-080		CAP, CHIP S 4P-50 C CH<VSC>
C482	87-010-405-080		CAP, ELECT 10-50V	C5	87-010-378-080		CAP, ELECT 10-16V
C489	87-012-368-080		C-CAP,S 0.1-50 F	C7	87-012-154-080		C-CAP,S 150P-50 CH<VSC>
C490	87-012-368-080		C-CAP,S 0.1-50 F	C7	87-012-156-080		C-CAP,S 220P-50 CH<GSC>
C491	87-010-197-080		CAP, CHIP 0.01 DM	C8	87-010-992-080		C-CAP,S 0.047-25 B<VSC>
C492	87-010-221-080		CAP, ELECT 470-10V	C8	87-010-197-080		CAP, CHIP 0.01 DM<GSC>
C494	87-010-197-080		CAP, CHIP 0.01 DM	C9	87-010-311-080		CAP 12P<GSC>
C501	87-012-368-080		C-CAP,S 0.1-50 F	C9	87-010-154-080		CAP CHIP 10P<VSC>
C502	87-010-322-080		C-CAP,S 100P-50 CH	C10	87-010-197-080		CAP, CHIP 0.01 DM
C503	87-010-322-080		C-CAP,S 100P-50 CH	C11	87-010-327-080		C-CAP,S 4P-50 UJ<VSC>
C504	87-010-322-080		C-CAP,S 100P-50 CH	C11	87-010-152-080		C-CAP,S 8P-50 CH<GSC>
C505	87-010-322-080		C-CAP,S 100P-50 CH	C12	87-010-314-080		C-CAP,S 22P-50V
C506	87-010-322-080		C-CAP,S 100P-50 CH	C13	87-010-322-080		C-CAP,S 100P-50 CH
C510	87-016-669-080		C-CAP,S 0.1-25 K B	C14	87-010-148-080		CAP, CHIP S 4P-50 C CH
C831	87-010-198-080		CAP, CHIP 0.022	C15	87-016-669-080		C-CAP,S 0.1-25 K B
CN202	8A-CH4-689-010		CONN,3P V 2.5	C16	87-010-178-080		CHIP CAP 1000P<GSC>
CN205	87-A60-109-010		CONN,2P V S2M-2W	C17	87-016-669-080		C-CAP,S 0.1-25 K B
CN301	8A-CH4-689-010		CONN,3P V 2.5	C18	87-016-669-080		C-CAP,S 0.1-25 K B<VSC>
CN401	87-A60-424-010		CONN,16P V TOC-B	C18	87-010-198-080		CAP, CHIP 0.022<GSC>
CN403	87-099-201-010		CONN,8P 6216 H	C19	87-016-669-080		C-CAP,S 0.1-25 K B
CN802	8A-CH4-687-010		CONN,4P V 2.5	C20	87-010-400-080		CAP, ELECT 0.47-50V
CNA402	8A-CDA-625-010		CONN ASSY,6P CD-ME	C21	87-010-403-080		CAP, ELECT 3.3-50V
L401	87-003-102-080		COIL, 10UH	C22	87-010-197-080		CAP, CHIP 0.01 DM
L404	87-003-152-080		COIL, 100UH	C24	87-010-189-080		C-CAP,S 8200P-50 B<VSC>
R840	87-029-124-010		RES,FUSE 2.2-1/4				
SFR430	87-024-437-080		SFR100K,RH063EC				
X401	8Z-CD5-633-010		VIB, CER16.93MHZ FCR16.93M2				

REF. NO	PART NO.	KANRI NO.	DESCRIPTION	REF. NO	PART NO.	KANRI NO.	DESCRIPTION
C25	87-010-189-080		C-CAP,S 8200P-50 B<VSC>	L53	87-A50-650-010		COIL,FM1 OSC V(ACD)<VSC>
C26	87-012-358-080		C-CAP,S 0.47-10 F Z	PVC1	87-A91-635-010		TUN-CAP,20P-140P E-ACD(MITSUMI
C27	87-012-358-080		C-CAP,S 0.47-10 F Z				<GSC>
C28	87-010-992-080		C-CAP,S 0.047-25 B<VSC>	PVC1	87-A91-169-010		TUN-CAP,40P-140P FA-22124 AN00
C28	87-010-992-080		C-CAP,S 0.047-25 B<GSC>				<VSC>
C29	87-010-992-080		C-CAP,S 0.047-25 B<GSC>	SW1	87-A91-884-010		SW,SL-4-4 SK44D01G6A<VSC>
C29	87-010-992-080		C-CAP,S 0.047-25 B<VSC>	SW1	87-A91-549-010		SW,SL-6-4 SK64D01G06<GSC>
C30	87-010-248-080		CAP, ELECT 220-10V	TC5	87-011-253-080		TRIMER,30P LAR<GSC>
C31	87-010-379-080		CAP, ELECT 22-16V	TC6	87-011-253-080		TRIMER,30P LAR<GSC>
C32	87-010-197-080		CAP, CHIP 0.01 DM	TC51	87-011-253-080		TRIMER,30P LAR<VSC>
				TC52	87-011-253-080		TRIMER,30P LAR<VSC>
C33	87-010-197-080		CAP, CHIP 0.01 DM				
C34	87-010-197-080		CAP, CHIP 0.01 DM				
C35	87-010-197-080		CAP, CHIP 0.01 DM	HP C.B			
C36	87-010-263-080		CAP, ELECT 100-10V				
C37	87-010-197-080		CAP, CHIP 0.01 DM	CN204	87-A60-685-010		CONN,4P H WHT EH
				CN605	87-A60-117-010		CONN,7P H S2M-7WR
C38	87-010-197-080		CAP, CHIP 0.01 DM<GSC>	CNA203	8A-CDA-628-110		CONN ASSY,4P MA-HP
C41	87-010-321-080		CHIP CAPACITOR,82P(J)<GSC>	J251	87-A60-569-010		JACK,HTJ-035-18
C42	87-010-150-080		C-CAP,S 6P-50 CH<GSC>	S606	87-A90-696-080		SW,TACT TS2103-03-430
C44	87-012-140-080		CAP 470P<GSC>				
C51	87-010-197-080		CAP, CHIP 0.01 DM	S607	87-A90-696-080		SW,TACT TS2103-03-430
				S608	87-A90-696-080		SW,TACT TS2103-03-430
C52	87-010-316-080		C-CAP,S 33P-50 CH<VSC>	S614	87-A90-696-080		SW,TACT TS2103-03-430
C53	87-010-341-080		C-CAP,S47P-50UJ<VSC>	S615	87-A90-696-080		SW,TACT TS2103-03-430
C54	87-010-197-080		CAP, CHIP 0.01 DM<VSC>				
C56	87-010-331-080		C-CAP,S 8P-50 UJ<VSC>	BATT1 C.B			
C57	87-010-197-080		CAP, CHIP 0.01 DM<VSC>				
C61	87-010-318-080		C-CAP,S 47P-50 CH<VSC>	C901	87-010-192-080		C-CAP,S 0.022-50 F
CF1	87-A90-128-010		FLTR,AM IF CFAL-455	C902	87-010-192-080		C-CAP,S 0.022-50 F
CF2	87-008-261-010		FILTER, SFE10.7MA5-A	C903	87-010-192-080		C-CAP,S 0.022-50 F
CF3	87-008-261-010		FILTER, SFE10.7MA5-A	C904	87-010-192-080		C-CAP,S 0.022-50 F
CN2	87-A60-116-010		CONN,6P H S2M-6WR	CNA901	8A-CDA-627-010		CONN ASSY,3P PWR
L2	87-A50-560-010		COIL,FM BPF(ACD)	△PR901	87-A90-092-080		PROTECTOR,2.5A 491
L3	8A-CD9-660-010		BAR-ANT,MW 2B-ACD(COI)<VSC>	SP901	87-CD6-213-010		SPR-C,BATT (-)
L3	8A-CD9-661-010		BAR-ANT,MW/LW 3B-ACD(COI)<GSC>	SP902	87-CD6-213-010		SPR-C,BATT (-)
L4	87-A50-562-010		COIL,FM RF EX(ACD)<GSC>				
L4	87-A50-647-010		COIL,FM2 RF V(ACD)<VSC>	BATT2 C.B			
L5	87-A50-564-010		COIL,FM OSC EX(ACD)<GSC>				
L5	87-A50-649-010		COIL,FM2 OSC V(ACD)<VSC>	SP903	87-CD6-213-010		SPR-C,BATT (-)
L6	87-A50-337-010		COIL,AM OSC (TOKO)<VSC>	SP904	87-CD6-213-010		SPR-C,BATT (-)
L7	87-A50-579-010		COIL,AM IFT(ACD)				
L8	87-A50-335-010		COIL,FM IFT (TOKO)	MOTOR C.B			
L9	87-A50-577-010		COIL,FM DET(ACD)				
L10	87-005-849-080		COIL,10UH(CECS)	M2	9X-262-576-910		MOTOR GEAR ASSY
L16	87-A50-569-010		COIL,LW OSC-ACD(COI)<GSC>	PIN3	91-564-722-110		CONNECTOR 6P
L17	87-A50-337-010		COIL,AM OSC (TOKO)<GSC>	SW1	91-572-085-120		LEAF SW
L52	87-A50-648-010		COIL,FM1 RF V(ACD)<VSC>				

- Regarding connectors, they are not stocked as they are not the initial order items. The connectors are available after they are supplied from connector manufacturers upon the order is received.

○チップ抵抗部品コード/CHIP RESISTOR PART CODE

チップ抵抗部品コードの成り立ち

Chip Resistor Part Coding



A  
抵抗部品コード  
Resistor Code

桁表示  
Figure  
抵抗値  
Value of resistor

チップ抵抗  
Chip resistor

容量 Wattage	種類 Type	許容誤差 Tolerance	記号 Symbol	寸法/Dimensions (mm)			抵抗コード : A Resistor Code : A	
				外形/Form	L	W		t
1/16W	1005	± 5%	CJ		1.0	0.5	0.35	104
1/16W	1608	± 5%	CJ		1.6	0.8	0.45	108
1/10W	2125	± 5%	CJ		2	1.25	0.45	118
1/8W	3216	± 5%	CJ		3.2	1.6	0.55	128

IC BLOCK DIAGRAM

IC, M62495AFP

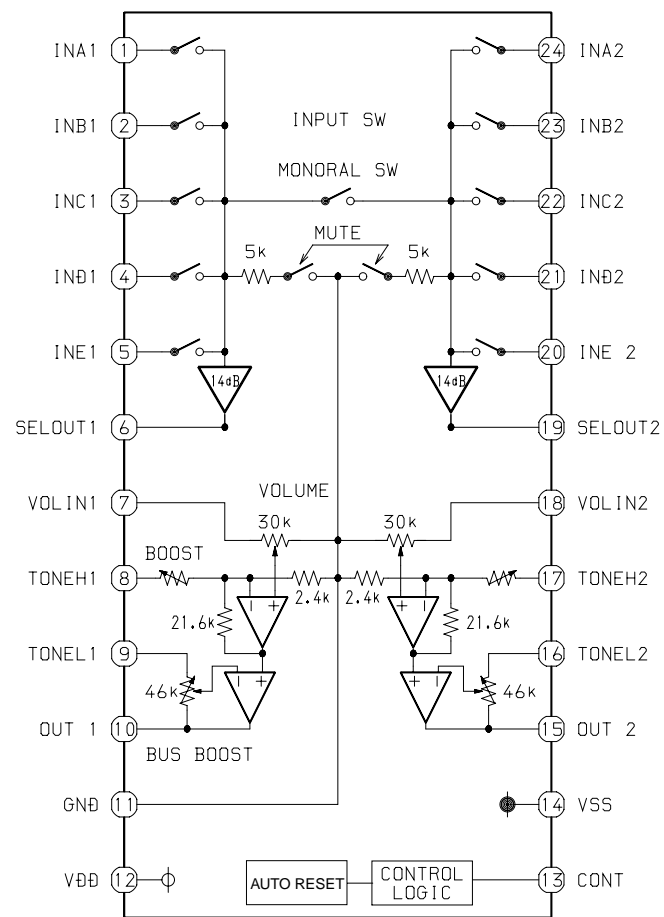

IC, BA6898S

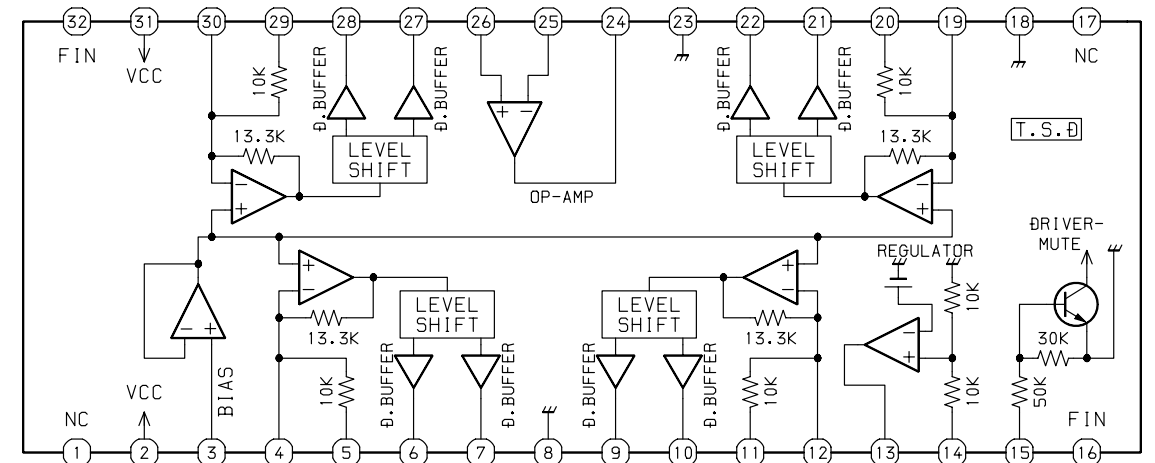

T.S.θ:Thermal shift down circuit  
D.BUFFER:Drive Buffer

IC, LA1828

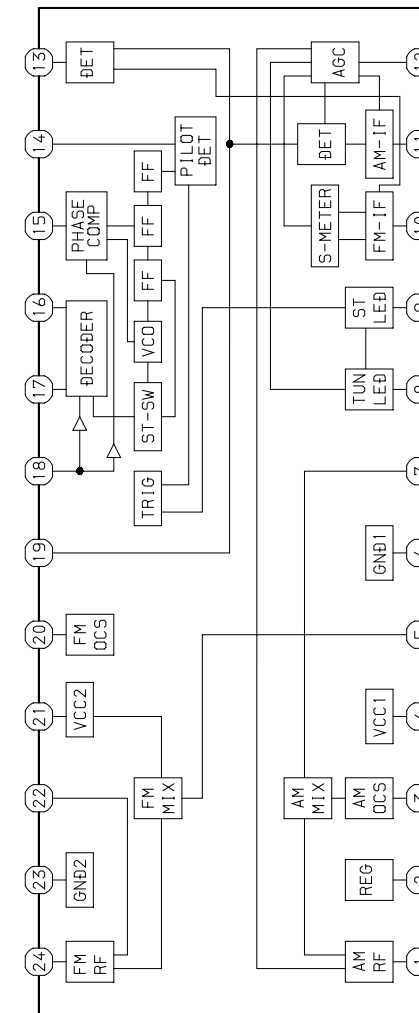

IC, NJM14558L

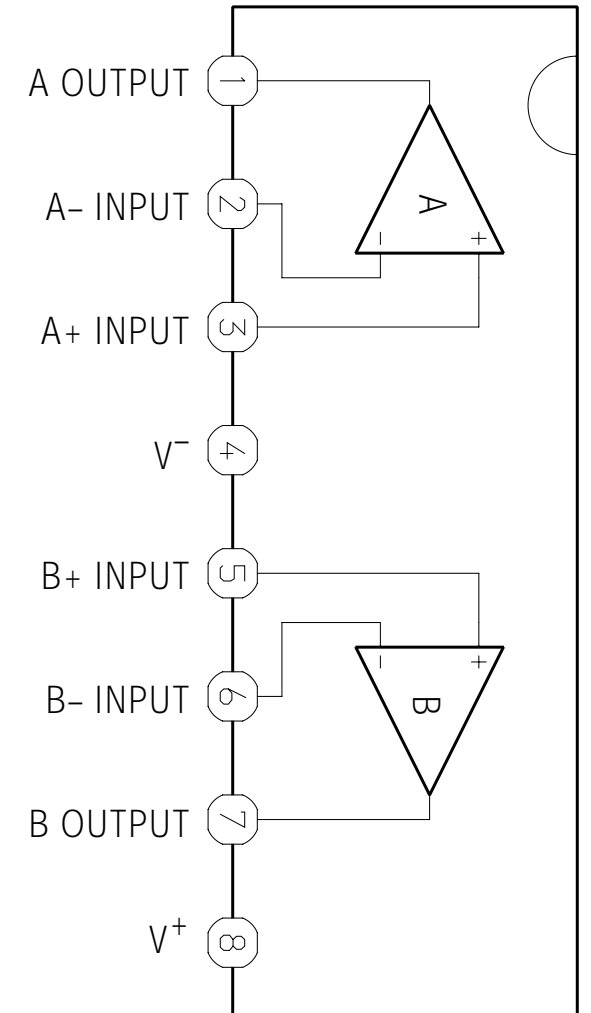

WIRING-1 (MAIN/CD)

1 2 3 4 5 6 7 8 9 10 11 12 13 14

A  
B  
C  
D  
E  
F  
G  
H  
I  
J  
K

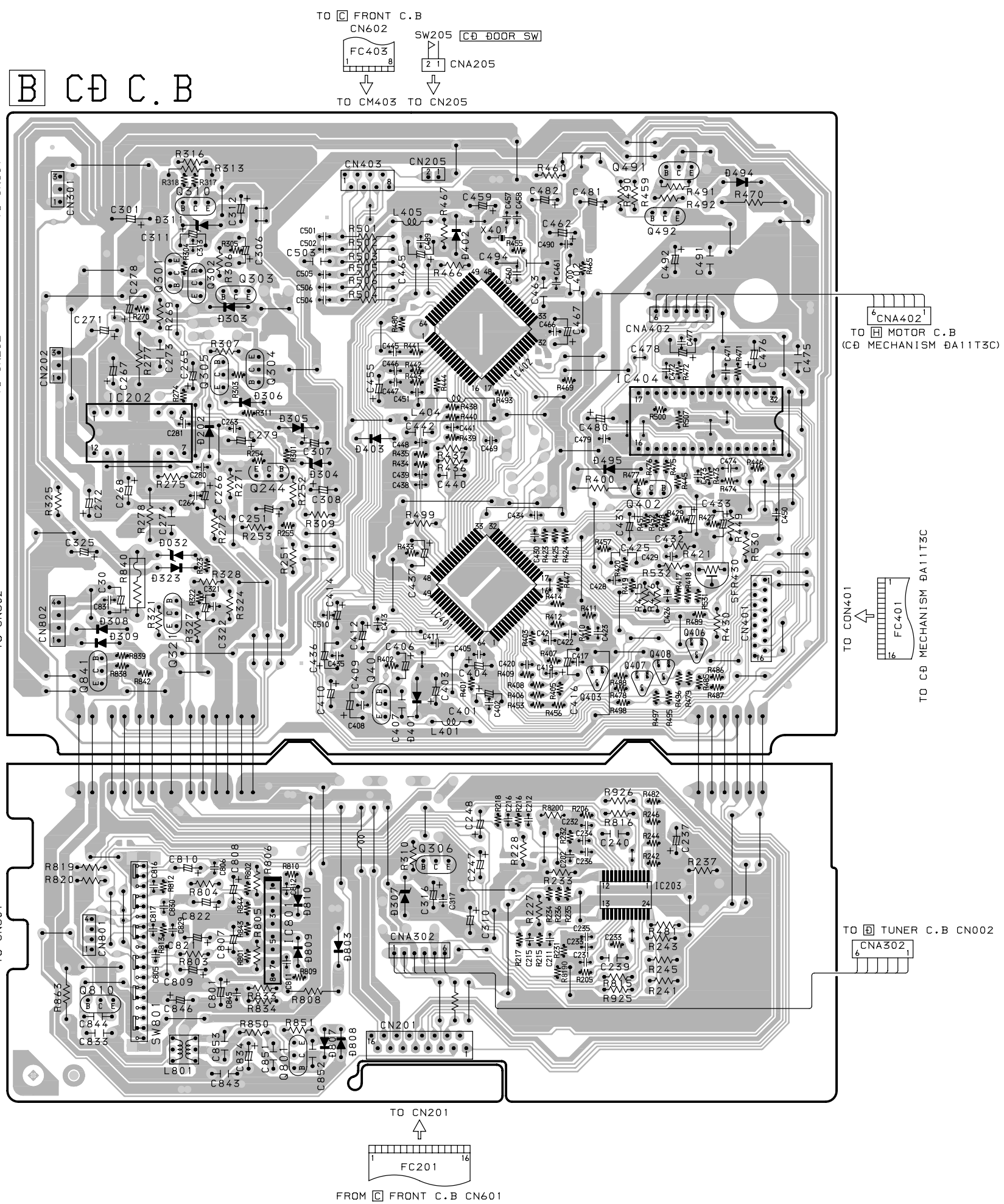

A MAIN C.B

B CD C.B

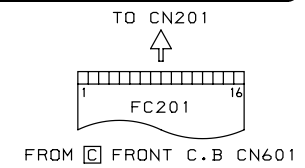
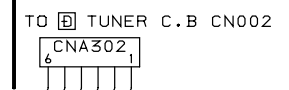
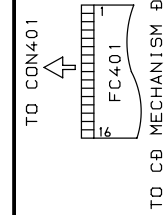
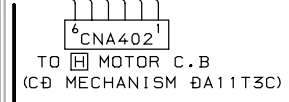
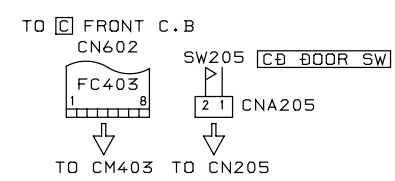
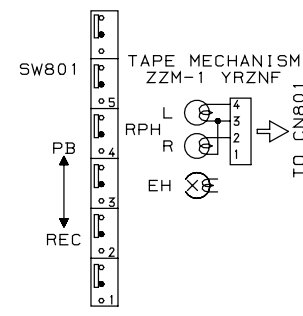
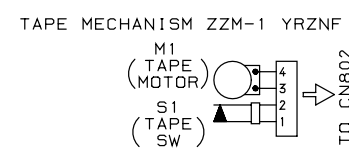
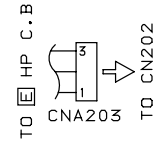
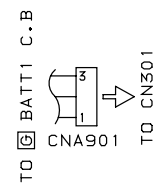



SCHEMATIC DIAGRAM-1 (MAIN)

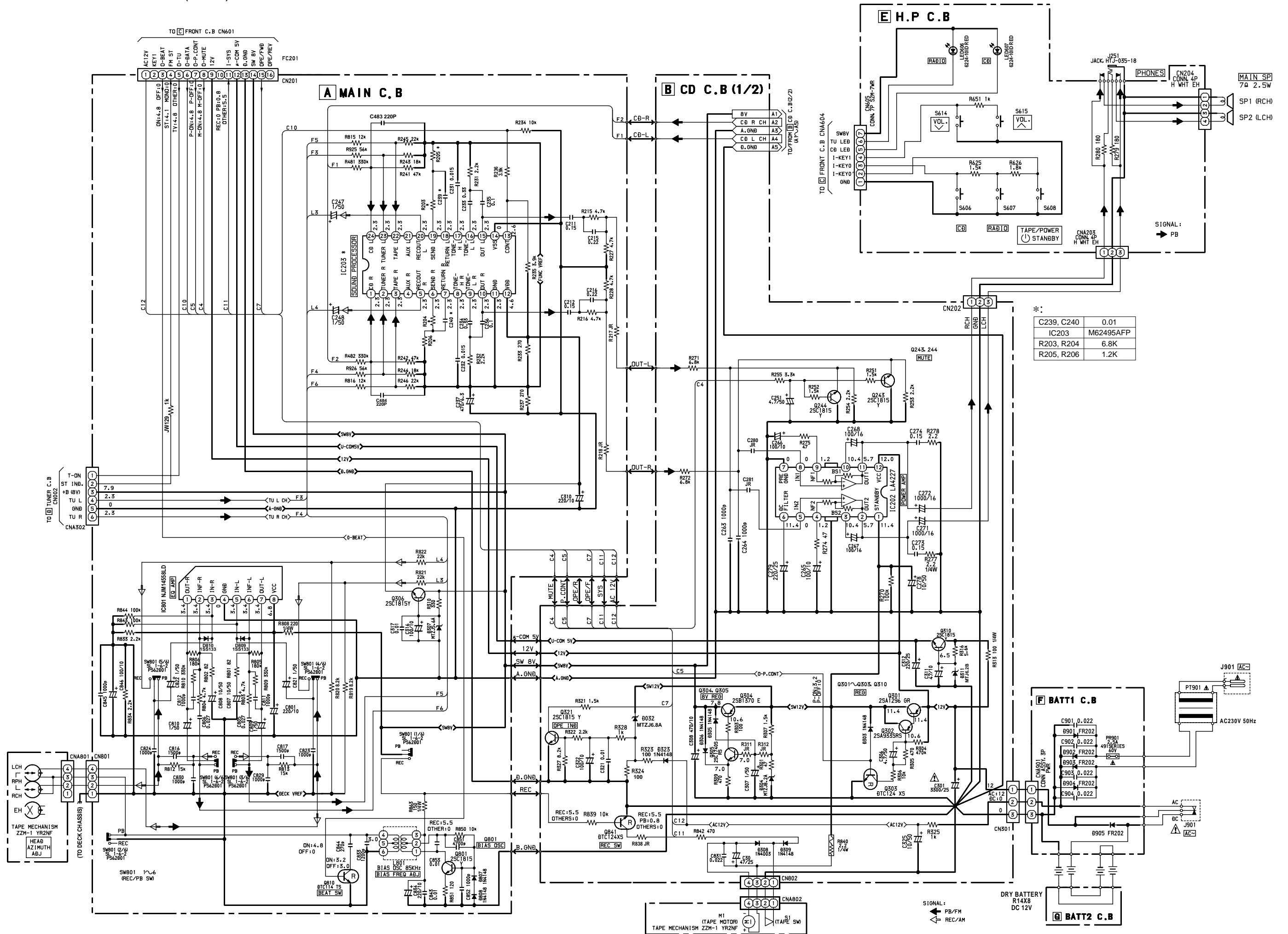

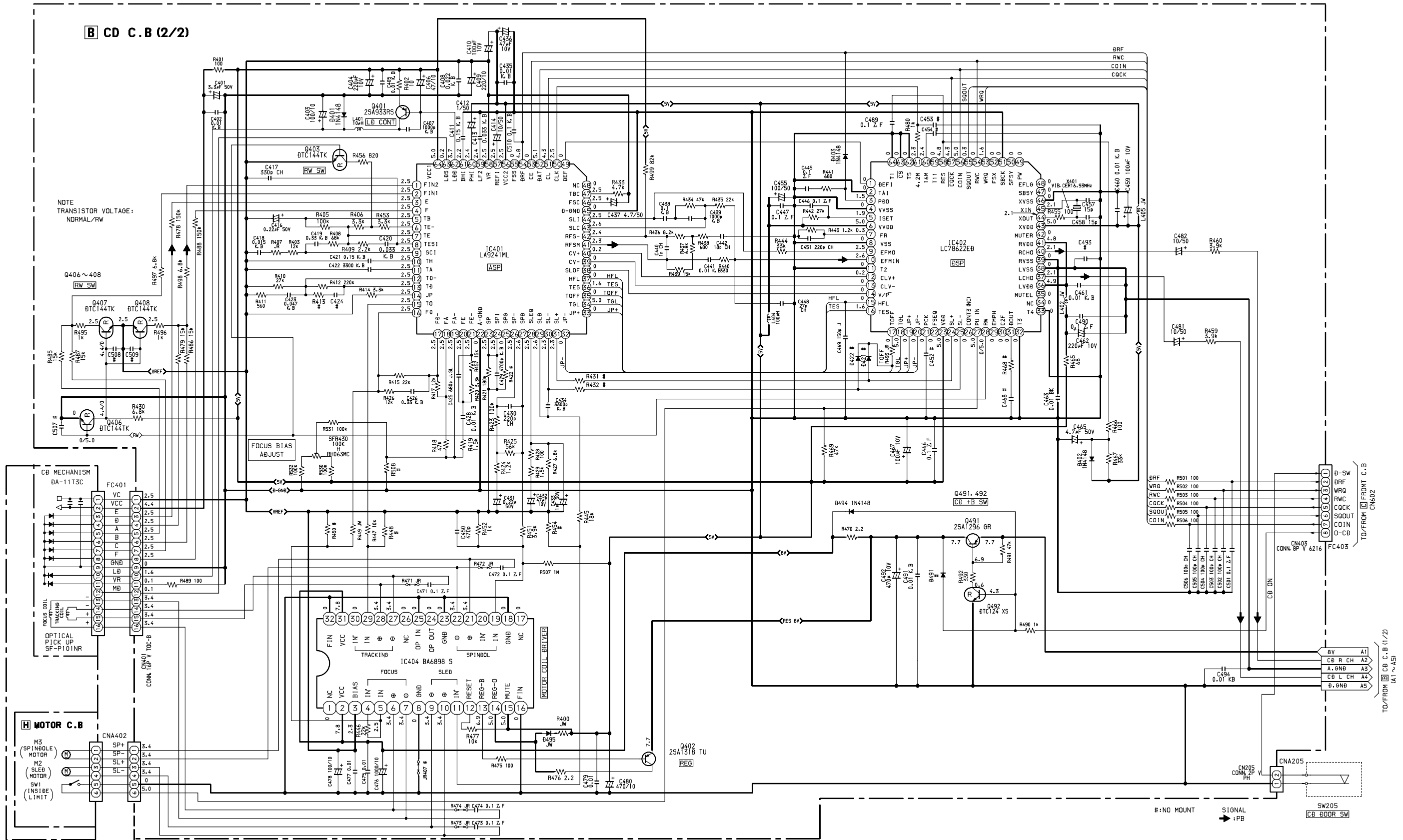

WIRING-2 (MOTOR)

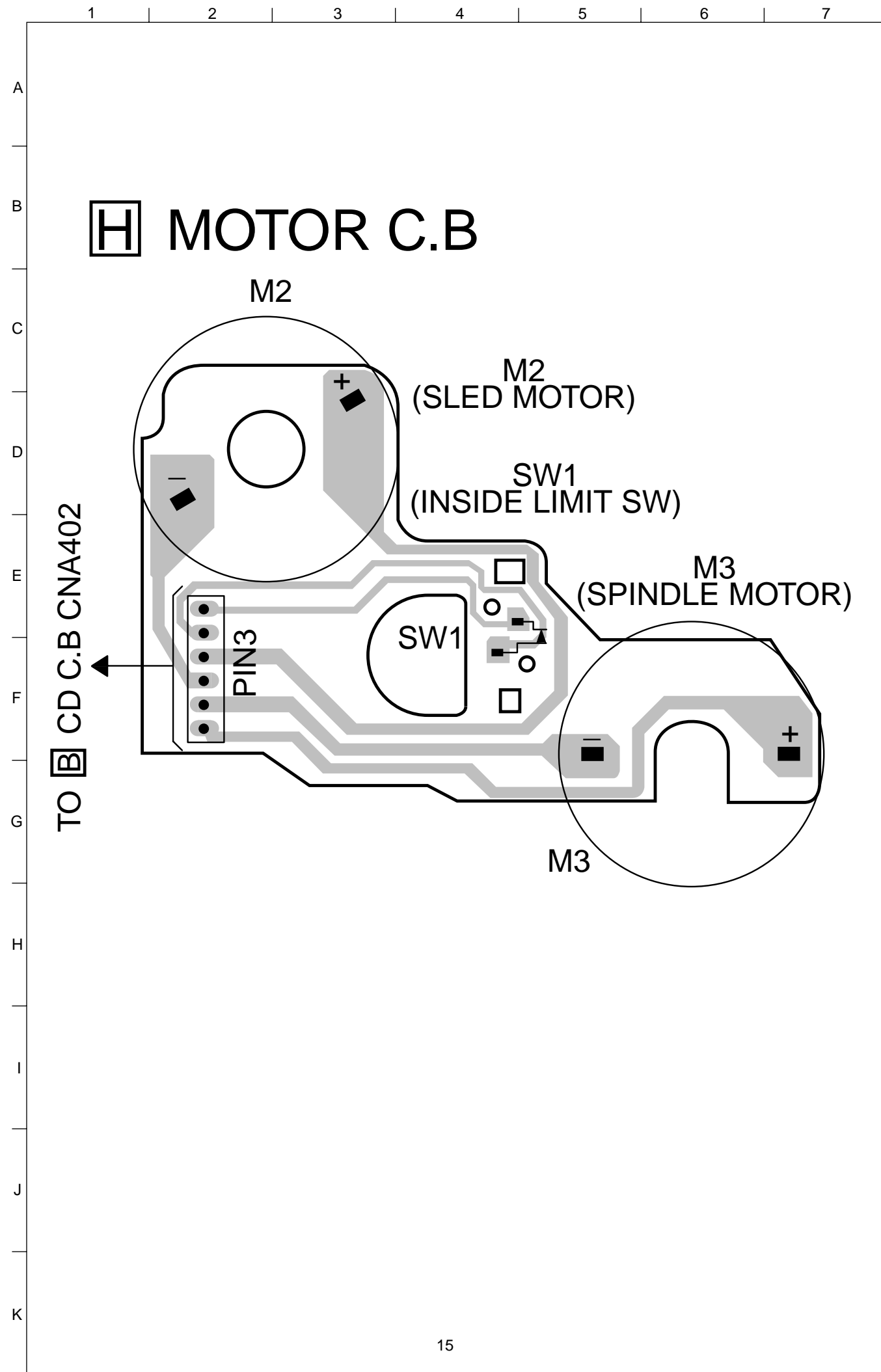

TRANSISTOR ILLUSTRATION

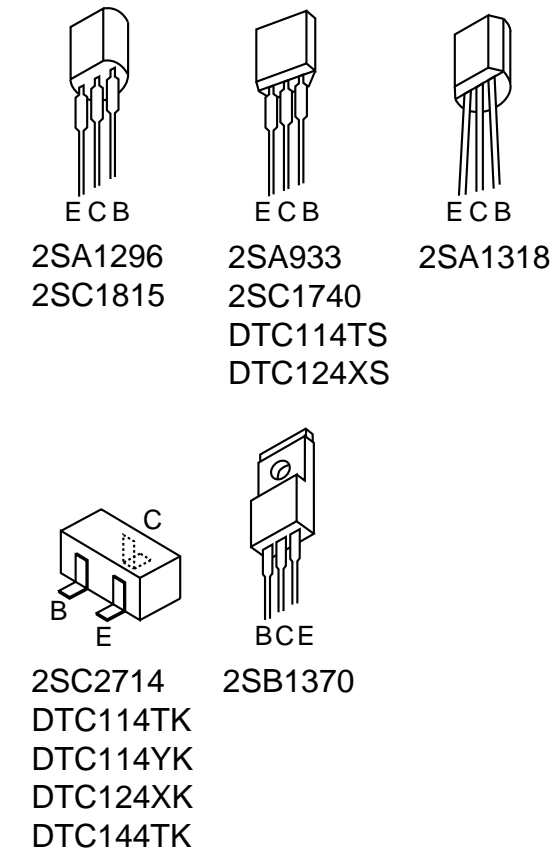

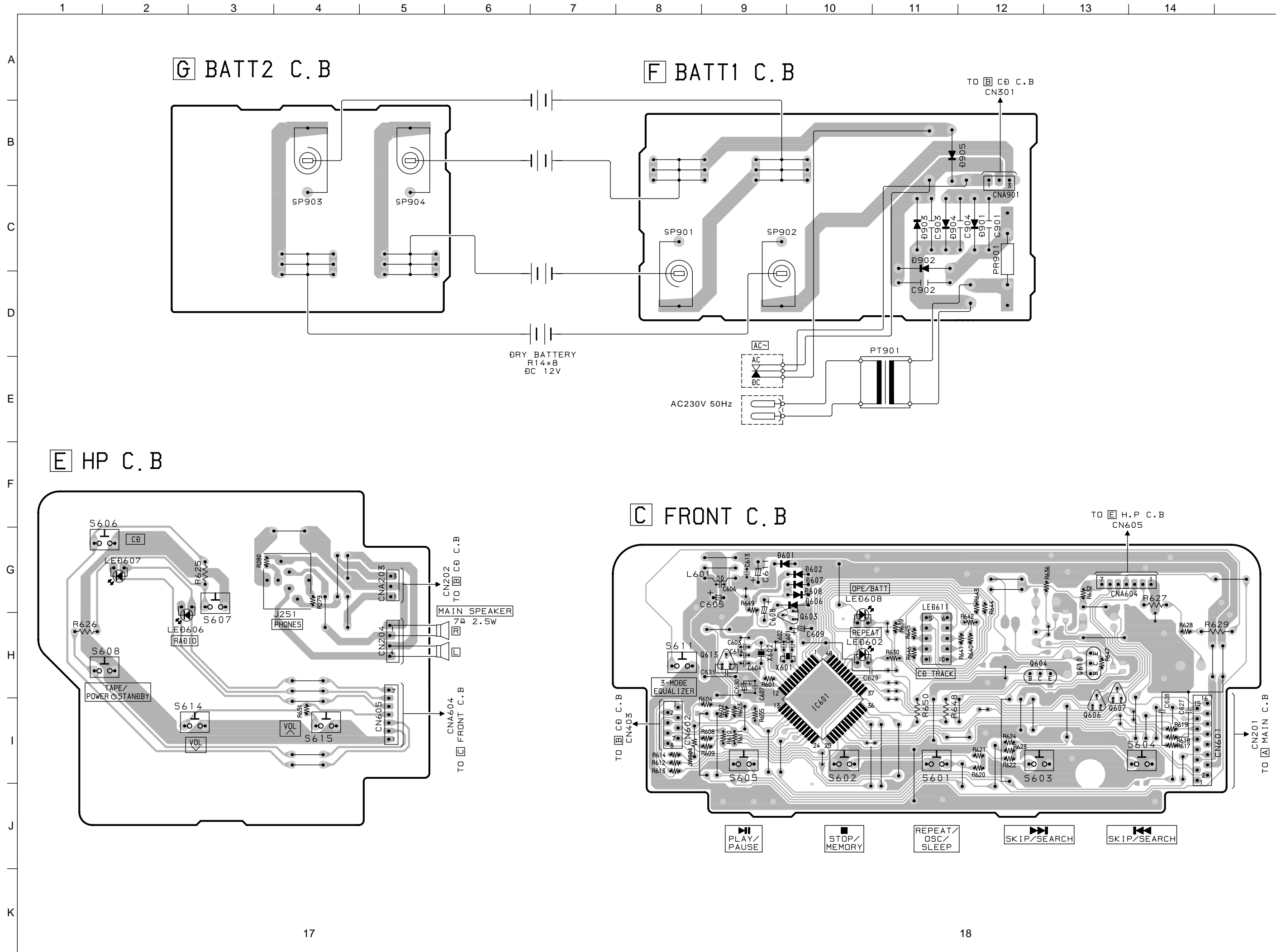

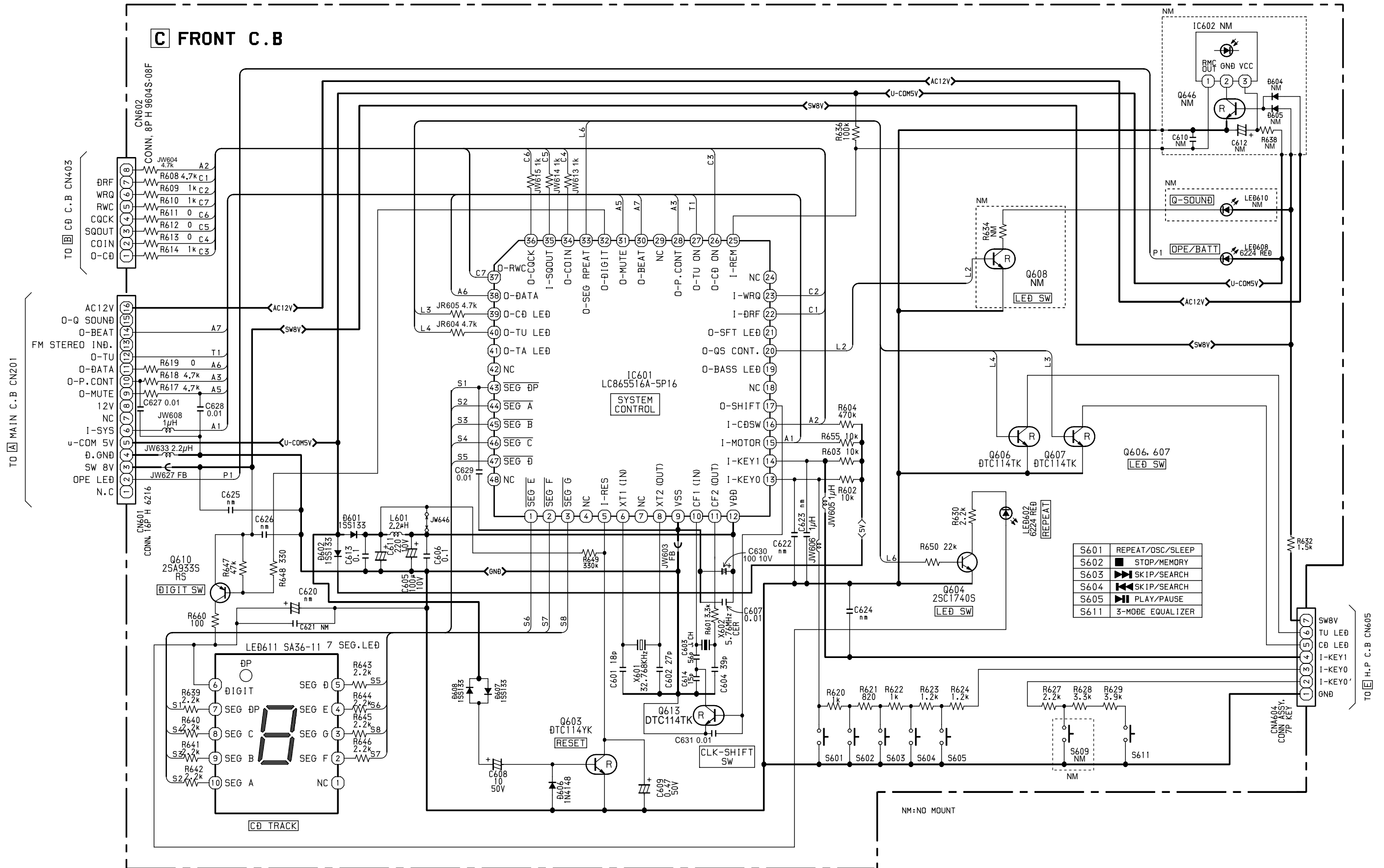

WIRING-4 (TUNER: VSC)

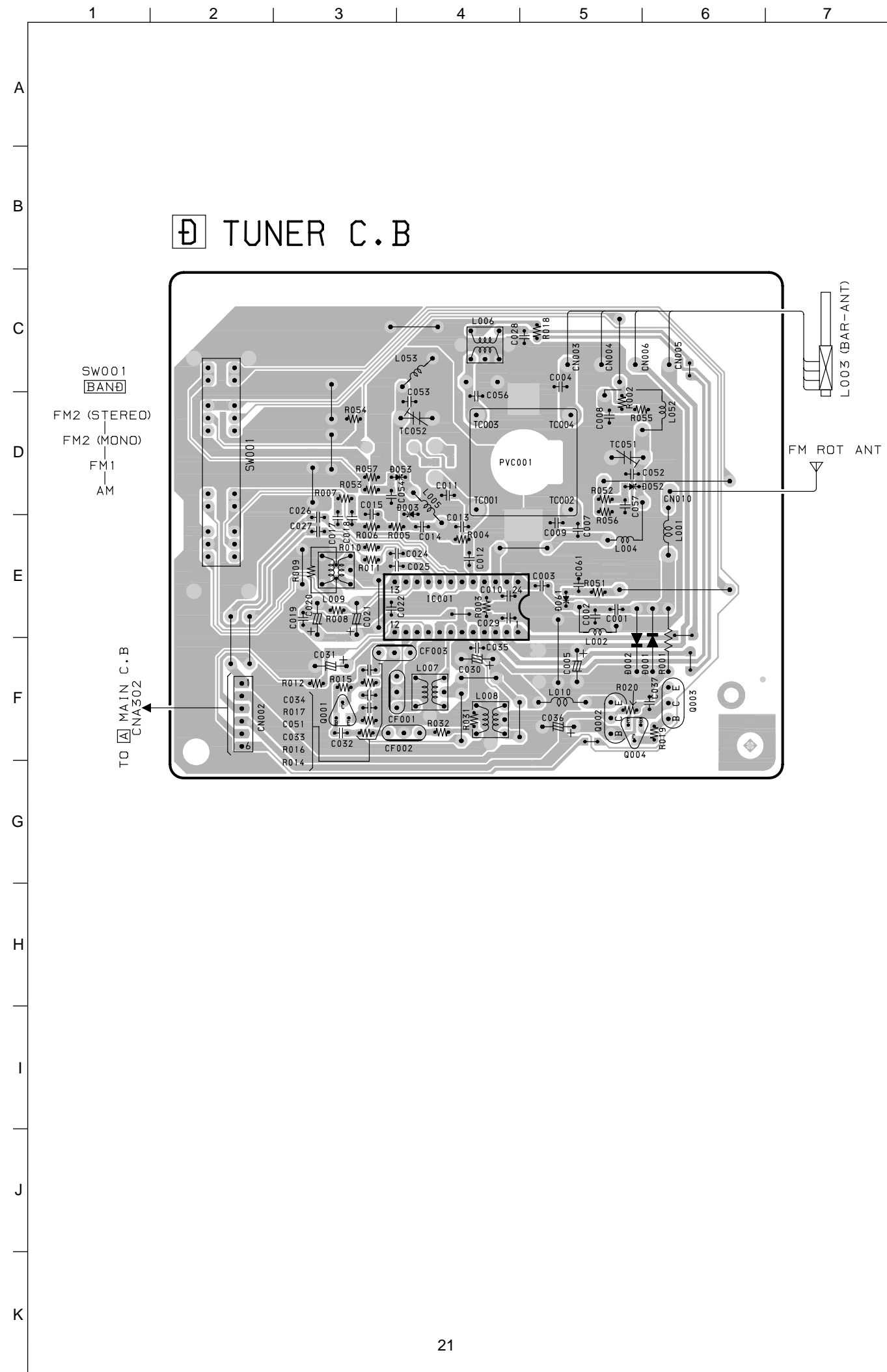

WIRING-5 (TUNER: GSC)

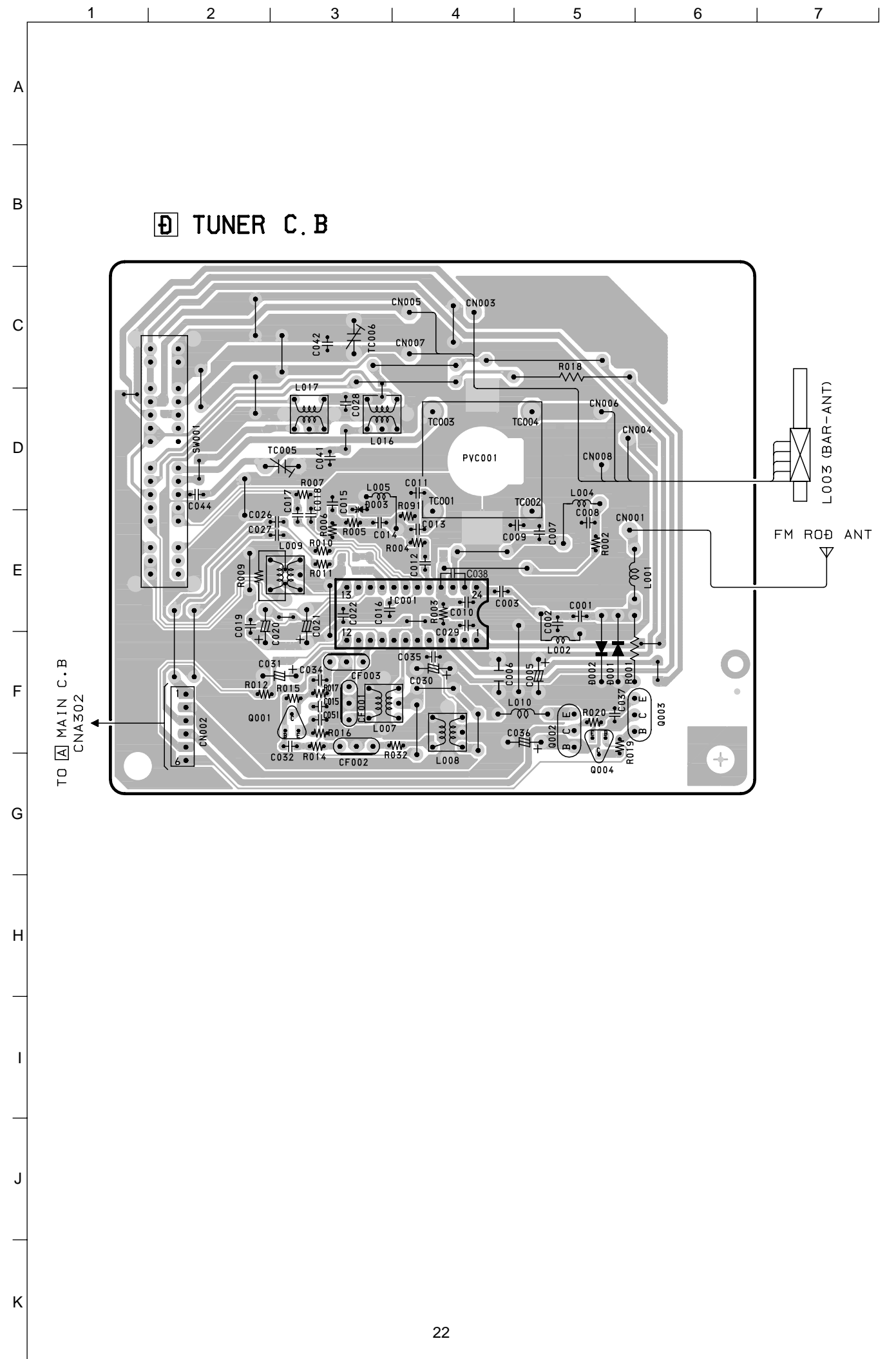

SCHEMATIC DIAGRAM-4 (TUNER: VSC)

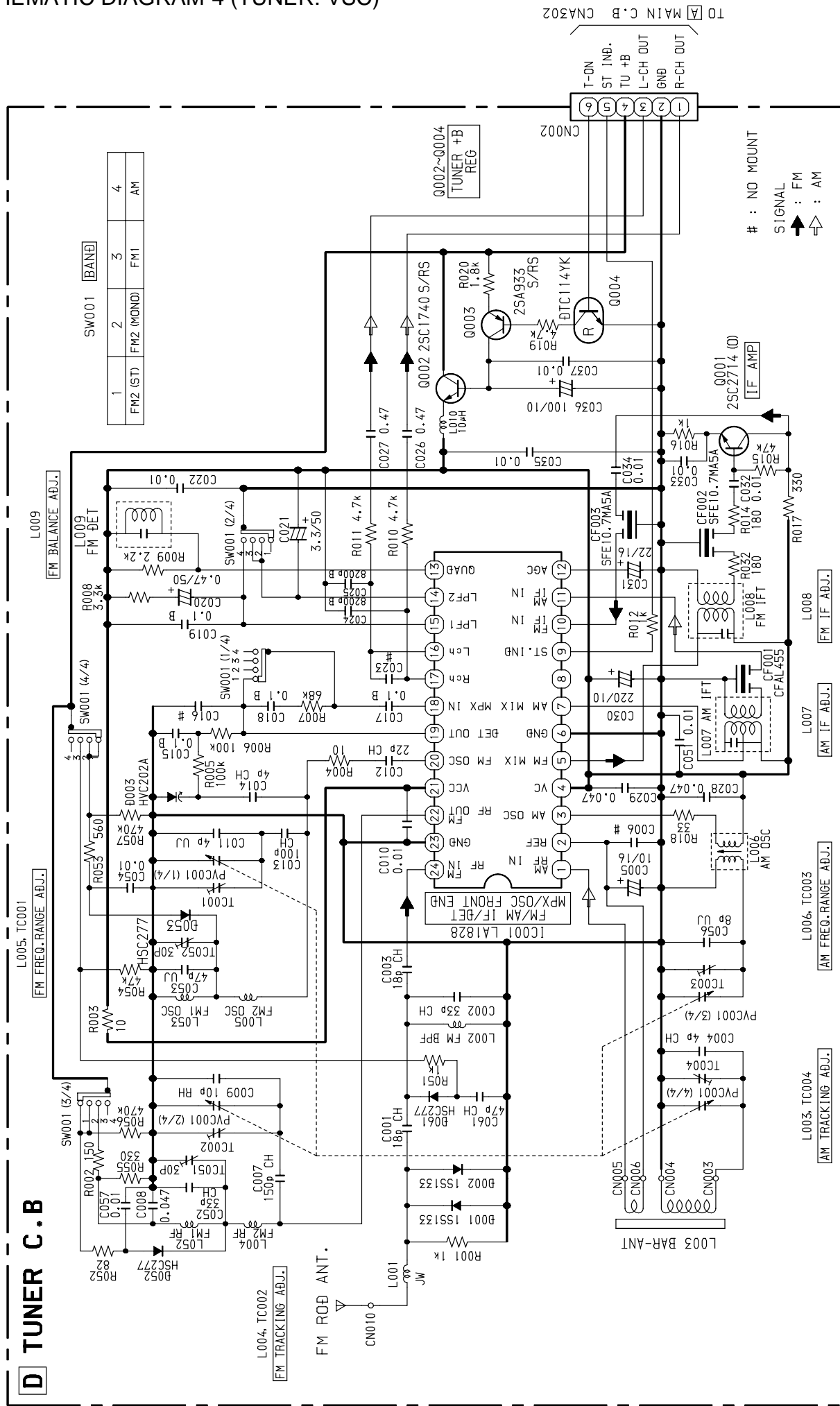

SCHEMATIC DIAGRAM-5 (TUNER: GSC)

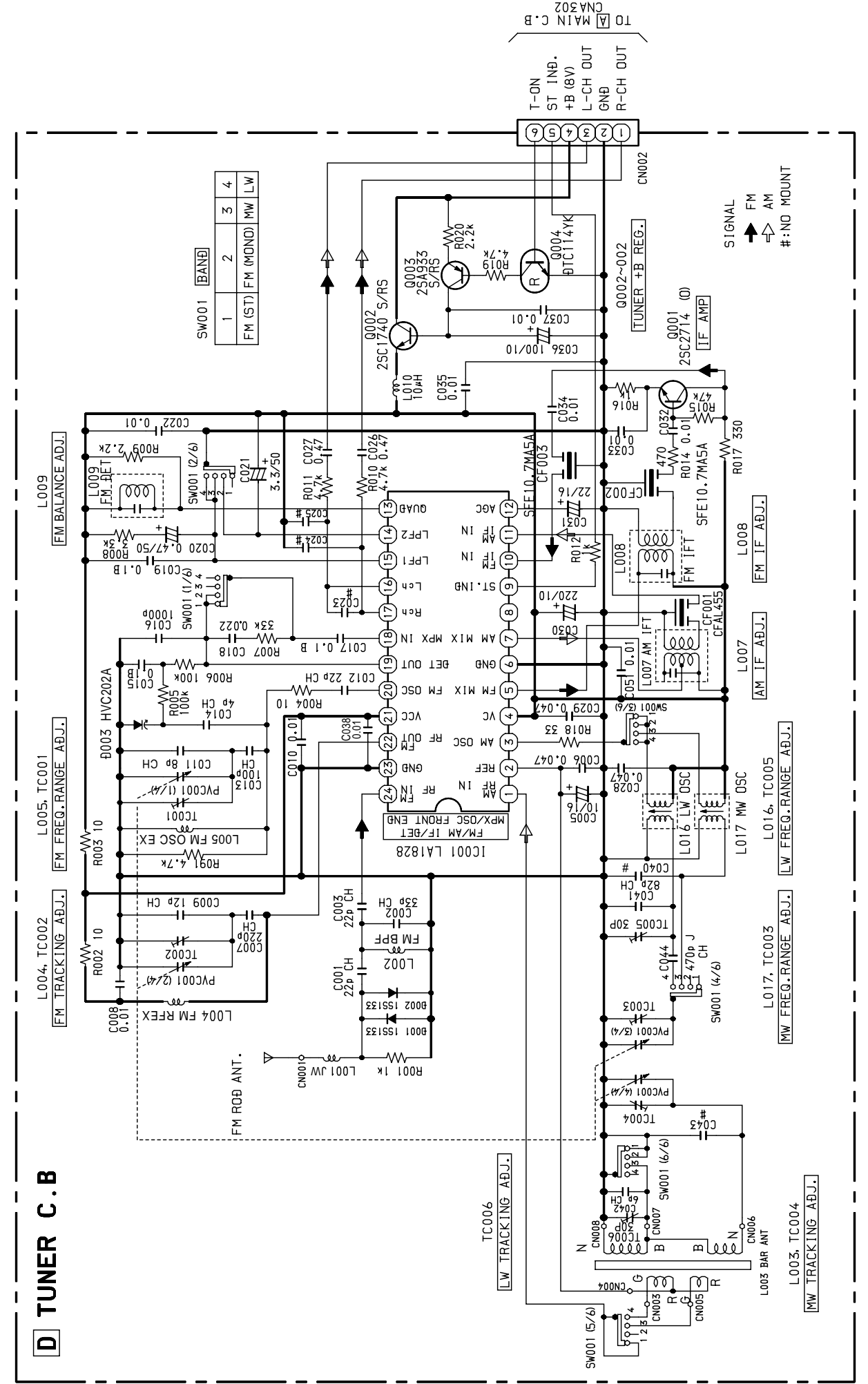

# ELECTRICAL ADJUSTMENT

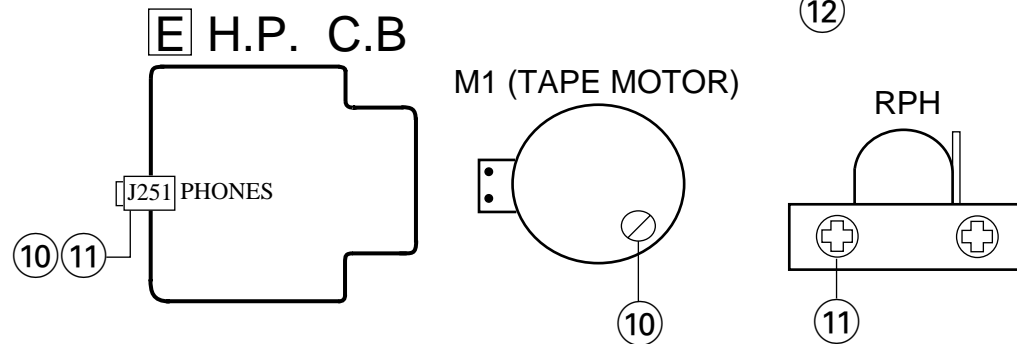
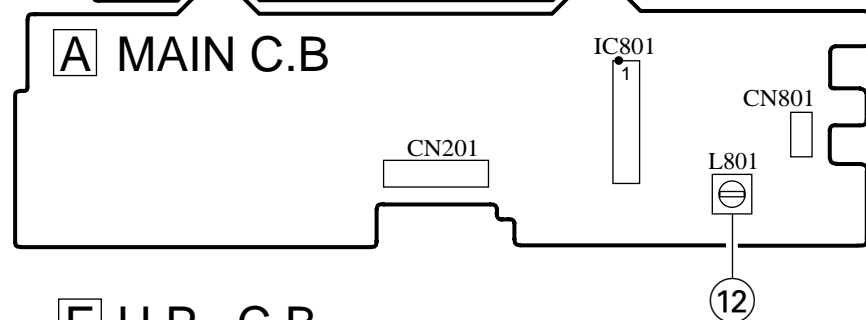
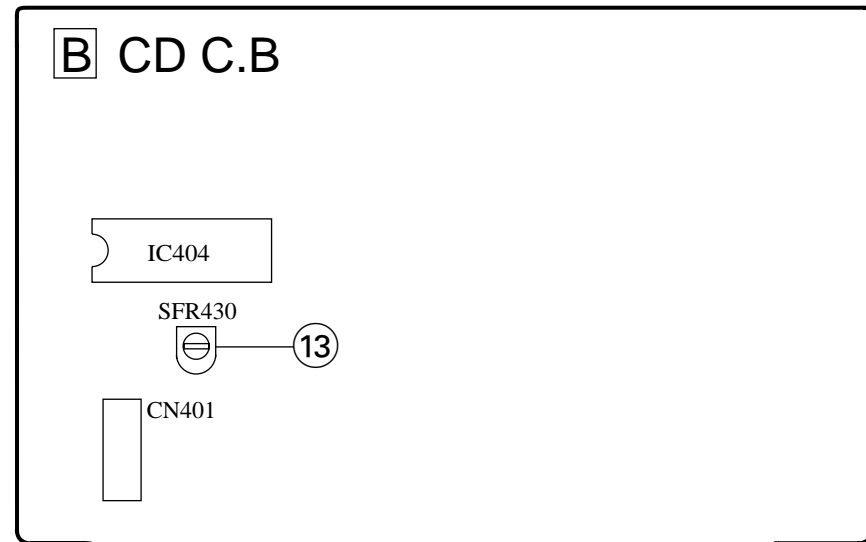
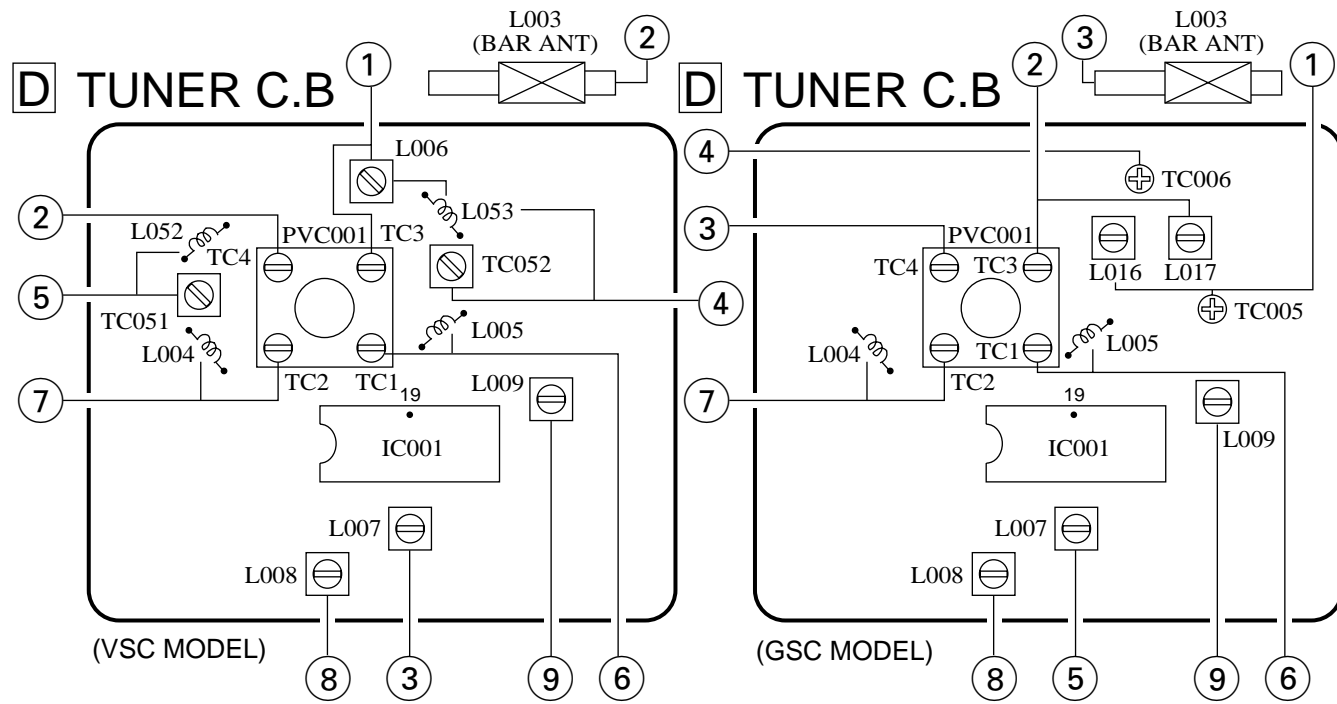

## < TUNER SECTION > (VSC MODEL)

- AM Freq. Range Adjustment  
L006 ..... 530kHz  
TC003 ..... 1605kHz
- AM Tracking Adjustment  
L003 ..... 603kHz  
TC004 ..... 1404kHz
- AM IF Adjustment  
Settings: • Test point: IC001 (LA1828) 19PIN  
• Adjustment location: L007  
Method: Adjust L007 so that the output level at 1400kHz becomes maximum.
- FM Freq. Range Adjustment  
L053 ..... 65.0MHz  
TC052 ..... 74.0MHz
- FM1 Tracking Adjustment  
L052 ..... 65.0MHz  
TC051 ..... 74.0MHz
- FM2 Freq. Range Adjustment  
L005 ..... 87.5MHz  
TC001 ..... 108.0MHz
- FM2 Tracking Adjustment  
L004 ..... 88.0MHz  
TC002 ..... 108.0MHz
- FM IF Adjustment  
Settings: • Test point: IC001 (LA1828) 19PIN  
• Adjustment location: L008  
Method: Adjust L008 so that the output level at 98.0MHz becomes balanced.
- FM Balance Adjustment  
Settings: • Test point: IC001 (LA1828) 19PIN  
• Adjustment location: L009  
Method: Adjust L009 so that the output level at 98.0MHz becomes balanced.

## (GSC MODEL)

- LW Freq. Range Adjustment  
L016 ..... 150kHz  
TC005 ..... 285kHz
- MW Freq. Range Adjustment  
L017 ..... 530kHz  
TC003 ..... 1605kHz
- MW Tracking Adjustment  
L003 ..... 603kHz  
TC004 ..... 1404kHz
- LW Tracking Adjustment  
TC006 ..... 288kHz

- AM IF Adjustment  
Settings: • Test point: IC001 (LA1828) 19PIN  
• Adjustment location: L007  
Method: Adjust L007 so that the output level at 1400kHz becomes maximum.
- FM Freq. Range Adjustment  
L005 ..... 87.5MHz  
TC001 ..... 108.0MHz
- FM Tracking Adjustment  
L004 ..... 88.0MHz  
TC002 ..... 108.0MHz
- FM IF Adjustment  
Settings: • Test point: IC001 (LA1828) 19PIN  
• Adjustment location: L008  
Method: Adjust L008 so that the output level at 98.0MHz becomes balanced.
- FM Balance Adjustment  
Settings: • Test point: IC001 (LA1828) 19PIN  
• Adjustment location: L009  
Method: Adjust L009 so that the output level at 98.0MHz becomes balanced.

## < DECK SECTION >

- Tape Speed Adjustment  
Settings : • Test tape : TTA-100  
• Test point : J251 (PHONES jack)  
• Adjustment location : SFR of deck motor  
Method : Play back the test tape and adjust SFR so that the frequency counter reads 3000Hz ± 30Hz.
- Head Azimuth Adjustment  
Settings : • Test tape : TTA-320  
• Test point : J251 (PHONES jack)  
• Adjustment location : Azimuth adjustment screw  
Method : Play back the 8kHz signal of the test tape and adjust screw so that the output becomes maximum.
- Bias frequency Adjustment  
L801 ..... 85kHz±0.5kHz

## < CD SECTION >

- FE Balance Adjustment  
Settings : • Test point : IC401 PIN58 (VR), IC401 PIN 20 (FE)  
• Adjustment location : SFR430  
Method : Playback the disc and adjust SFR430 so that the test point voltage becomes 0V.



## PRACTICAL SERVICE FIGURE

### < TUNER SECTION >

#### < FM1 SECTION > (VSC)

Sensitivity:	Less than 20dB (65.0MHz)
(THD 3%)	Less than 18dB (70.0MHz)
	Less than 20dB (74.0MHz)
Signal to Noise Ratio:	More than 60dB (at 70.0MHz)
(Input 60dB)	
Distortion:	Less than 2.0% (at 70.0MHz)
(Input 60dB)	
Intermediate frequency:	10.7MHz $\pm$ 0.1MHz

#### < FM2 SECTION > (VSC/GSC)

Sensitivity:	Less than 18dB (87.5MHz)
(THD 3%)	Less than 18dB (98.0MHz)
	Less than 18dB (108.0MHz)
Signal to Noise Ratio:	More than 60dB (at 98.0MHz)
(Input 60dB)	
Distortion:	Less than 2.0% (at 98.0MHz)
(Input 60dB)	
Intermediate frequency:	10.7MHz $\pm$ 0.1MHz
Stereo separation:	More than 25dB (at 98.0MHz)

#### < AM SECTION > (VSC/GSC)

Sensitivity:	Less than 48dB (at 603kHz)
(S/N 10dB)	Less than 46dB (at 999kHz)
	Less than 44dB (at 1404kHz)
Distortion:	Less than 3.0%
(Input 74dB)	
Intermediate frequency:	455kHz $\pm$ 3.5kHz

#### < LW SECTION > (GSC)

Sensitivity:	Less than 60dB (at 153kHz)
(S/N 10dB)	Less than 56dB (at 198kHz)
	Less than 52dB (at 288kHz)
Signal to Noise Ratio:	More than 30dB
Distortion:	Less than 3.0% (at 198kHz)
(Input 80dB)	

#### < CASSETTE SECTION > (VSC/GSC)

Tape speed:	3000Hz+3%-2%
Wow & flutter:	Less than 0.35% (JIS RMS)
S/N ratio:	More than 35dB
Distortion:	Less than 3.0% (PB)
Noise (PB):	Less than 1mV
	(DC, MIN)
	Less than 1.2mV (AC, MIN)
Erasing Ratio (W/O FILTER):	More than 45dB

# IC DESCRIPTION

## IC, LA9241ML

Pin No.	Pin Name	I/O	Description
1	FIN2	I	Pin to which external pickup photo diode is connected. RF signal is created by adding with the FIN1 pin signal. FE signal is created by subtracting from the FIN1 pin signal.
2	FIN1	I	Pin to which external pickup photo diode is connected.
3	E	I	Pin to which external pickup photo diode is connected. TE signal is created by subtracting from the F pin signal.
4	F	I	Pin to which external pickup photo diode is connected.
5	TB	I	DC component of the TE signal is input.
6	TE-	I	Pin to which external resistor setting the TE signal gain is connected between the TE pin.
7	TE	O	TE signal output pin.
8	TESI	I	TES “Track Error Sense” comparator input pin. TE signal is passed through a band-pass filter then input.
9	SCI	I	Shock detection signal input pin.
10	TH	I	Tracking gain time constant setting pin.
11	TA	O	TA amplifier output pin.
12	TD-	I	Pin to which external tracking phase compensation constants are connected between the TD and VR pins.
13	TD	I	Tracking phase compensation setting pin.
14	JP	I	Tracking jump signal (kick pulse) amplitude setting pin.
15	TO	O	Tracking control signal output pin.
16	FD	O	Focusing control signal output pin.
17	FD-	I	Pin to which external focusing phase compensation constants are connected between the FD and FA pins.
18	FA	I	Pin to which external focusing phase compensation constants are connected between the FD- and FA- pins.
19	FA-	I	Pin to which external focusing phase compensation constants are connected between the FA and FE pins.
20	FE	O	FE signal output pin.
21	FE-	I	Pin to which external FE signal gain setting resistor is connected between the FE pin.
22	AGND	—	Analog signal GND.
23	NC	—	No connection.
24	SP	O	Signal ended output of the CV+ and CV- pin input signal.
25	SPG	I	Pin to which external spindle gain setting resistor in 12 cm mode is connected.
26	SP-	I	Pin to which external spindle phase compensation constants are connected together with SPD pin.
27	SPD	O	Spindle control signal output pin.
28	SLEQ	I	Pin to which external sled phase compensation constants are connected.
29	SLD	O	Sled control signal output pin.
30, 31	SL-, SL+	I	Sled advance signal input pin from microprocessor.
32, 33	JP-, JP+	I	Tracking jump signal input pin from DSP.
34	TGL	I	Tracking gain control signal input from DSP. Low gain when TGL = H.
35	TOFF	I	Tracking off control signal input pin from DSP. Off when TOFF = H.

Pin No.	Pin Name	I/O	Description
36	TES	O	Pin from which TES signal is output to DSP.
37	HFL	O	“High Frequency Level” is used to judge whether the main beam position is on top of bit or on top of mirror.
38	SLOF	I	Sled servo off control input pin.
39, 40	CV-, CV+	I	CLV error signal input pin from DSP.
41	RFSM	O	RF output pin.
42	RFS-	I	RF gain setting and EFM signal 3T compensation constant setting pin together with RFSM pin.
43	SLC	O	“Slice Level Control” is the output pin which controls the RF signal data slice level by DSP.
44	SLI	I	Input pin which control the data slice level by the DSP.
45	DGND	—	Digital system GND.
46	FSC	O	Output pin to which external focus search smoothing capacitor is connected.
47	TBC	I	“Tracking Balance Control” EF balance variable range setting pin.
48	NC	—	No connection.
49	DEF	O	Disc defect detector output pin.
50	CLK	I	Reference clock input pin. 4.23 MHz of the DSP is input.
51	CL	I	Microprocessor command clock input pin.
52	DAT	I	Microprocessor command data input pin.
53	CE	I	Microprocessor command chip enable input pin.
54	DRF	O	“Detect RF” RF level detector output.
55	FSS	I	“Focus Search Select” focus search mode ( $\pm$ search/+ search) select pin.
56	VCC2	—	Servo system and digital system Vcc pin.
57	REFI	—	Pin to which external bypass capacitor for reference voltage is connected.
58	VR	O	Reference voltage output pin.
59	LF2	I	Disc defect detector time constant setting pin.
60	PH1	I	Pin to which external capacitor for RF signal peak holding is connected.
61	BH1	I	Pin to which external capacitor for RF signal bottom holding is connected.
62	LDD	O	APC circuit output pin.
63	LDS	I	APC circuit input pin.
64	VCC1	—	RF system Vcc pin.

## IC, LC78622ED

Pin No.	Pin Name	I/O	Description	
1	DEFI	I	Defect sense signal (DEF) input pin. (Connect to 0V when not used).	
2	TAI	I	For PLL.	Test signal input pin with built-in pull-down resistor. Be sure to connect to 0V.
3	PDO	O		Phase comparator output pin to control external VCO.
4	VVSS	—		GND pin for built-in VCO. Be sure to connect to 0V.
5	ISET	I		Pin to which external resistor adjusting the PDO output current.
6	VVDD	—		Power supply pin for built-in VCO.
7	FR	I		Pin for VCO frequency range adjustment.
8	VSS	—		Digital system GND. Be sure to connect to 0V.
9	EFMO	O	For slice level control.	EFM signal output pin.
10	EFMIN	I		EFM signal input pin.
11	T2	I	Test signal input pin with built-in pull-down resistor. Be sure to connect to 0V.	
12, 13	CLV+, CLK-	O	Disc motor control output. Three level output is possible using command.	
14	V/P	O	Rough servo or phase control automatic selection monitoring output pin. Rough servo at H. Phase servo at L.	
15	HFL	I	Track detect signal input pin. Schmidt input.	
16	TES	I	Tracking error signal input pin. Schmidt input.	
17	TOFF	O	Tracking OFF output pin.	
18	TGL	O	Tracking gain selection output pin. Gain boost at L.	
19, 20	JP+, JP-	O	Track jump control signal output pin. Three level output is possible using command.	
21	PCK	O	EFM data playback clock monitoring pin 4.3218 MHz when phase is locked in.	
22	FSEQ	O	Sync signal detection output pin. H when the sync signal which is detected from EFM signal and the sync signal which is internally generated agree.	
23	VDD	—	Digital system power supply pin.	
24	SL+	O	Moves the sled to outer circumference.	
25	SL-	O	Moves the sled to inner circumference.	
26	—	—	Not connected.	
27	PUIN	I	CD pickup inner switch detection.	
28	RW	O	Read, wright signal.	
29	EMPH	O	De-emphasis monitor output pin. De-emphasis disc is being played back at H.	
30	C2F	O	C2 flag output pin.	
31	DOUT	O	DIGITAL OUT output pin. (EIAJ format).	
32, 33	T3, T4	I	Test signal input pin with built-in pull-down resistor. Be sure to connect to 0V.	
34	N.C.	—	Not used. Set the pin to open.	
35	MUTEL	O	L-channel 1-bit DAC.	L-channel mute output pin.
36	LVDD	—		L-channel power supply pin.
37	LCHO	O		L-channel output pin.
38	LVSS	—		L-channel GND. Be sure to connect to 0V.
39	RVSS	—	R-channel 1-bit DAC.	R-channel GND. Be sure to connect to 0V.
40	RCHO	O		R-channel output pin.
41	RVDD	—		R-channel power supply pin.
42	MUTER	O		R-channel mute output pin.

Pin No.	Pin Name	I/O	Description
43	XVDD	—	Crystal oscillator power supply pin.
44	XOUT	O	Pin to which external 16.9344 MHz crystal oscillator is connected.
45	XIN	I	
46	XVSS	—	Crystal oscillator GND pin. Be sure to connect to 0V.
47	SBSY	O	Subcode block sync signal output pin.
48	EFLG	O	C1, C2, single and dual correction monitoring pin.
49	PW	O	Subcode P, Q, R, S, T, U and W output pin.
50	SFSY	O	Subcode frame sync signal output pin. Falls down when subcode enters standby.
51	SBCK	I	Subcode read clock input pin. Schmidt input. (Be sure to connected to 0V when not in use.)
52	FSX	O	Pin outputting the 7.35 kHz sync signal which is generated by dividing frequency of crystal oscillator.
53	WRQ	O	Subcode Q output standby output pin.
54	RWC	I	Read/write control input pin. Schmidt input.
55	SQOUT	O	Subcode Q output pin.
56	COIN	I	Command input pin from microprocessor.
57	$\overline{\text{CQCK}}$	I	Command input read clock or subcode read input clock from SQOUT pin
58	RES	I	LC78622 reset input pin. Set this pin to L once when the main power is turned on.
59	T11	O	Test signal output pin. Use this pin as open (normally L output).
60	16M	O	16.9344 MHz output pin.
61	4.2M	O	4.2336 MHz output pin.
62	T5	I	Test signal input pin with built-in pull-down resistor. Be sure to connect to 0V.
63	$\overline{\text{CS}}$	I	Chip select signal input pin with built-in pull-down resistor. Be sure to connect to 0V while it is not controlling.
64	T1	I	Test signal input pin without built-in pull-down resistor. Be sure to connect to 0V.

## IC, LC865516A-5P16

Pin No.	Pin Name	I/O	Description
1	$\overline{\text{SEG E}}$	O	SEG E control.
2	$\overline{\text{SEG F}}$	O	SEG F control.
3	$\overline{\text{SEG G}}$	O	SEG G control.
4	NC	—	Not connected.
5	I-RES	I	Micro processor reset input
6	XT(IN)	I	Connected to an external 32.768 kHz crystal oscillator.
7	NC	—	Not connected.
8	XT2(OUT)	O	Connected to an external 32.768 kHz crystal oscillator.
9	VSS	—	GND.
10	CF1(IN)	I	Connected to an external 5.76 MHz ceramic filter.
11	CF2(OUT)	O	Connected to an external 5.76 MHz ceramic filter.
12	VDD	—	Microprocessor power supply (+5V).
13	I-KEY0	I	Key AD input. (AD)
14	I-KEY1	I	Key AD input. (AD)
15	I-MOTOR	I	Deck status input. (AD)
16	I-CD SW	I	CD door switch status input.
17	O-SHIFT	O	Main clock shift output.
18	NC	—	Not connected.
19	O-BASS LED	O	BASS LED ON/OFF control output. (Not connected)
20	O-QS LED	O	Q sound LED ON/OFF control output. (Not connected)
21	O-SFT LED	—	Not connected.
22	I-DRF	I	CD RF level detection input.
23	I-WRQ	I	CD subcode Q standby input.
24	NC	—	Not connected.
25	I-REM	—	Remote control input.
26	O-CD ON	O	CD power control output.
27	O-TU ON	O	TU power control output.
28	O-P.CONT	O	The main power supply control output.
29	NC	—	Not connected.
30	O-BEAT	O	Beat control.
31	O-MUTE	O	Main mute output.
32	O-DIGIT	O	7-segment LED power supply control output.
33	O-SEG RPEAT	O	REPEAT LED ON/OFF control output.
34	O-COIN	O	CD command output.
35	I-SQOUT	I	CD subcode Q input.
36	O-CQCK	O	CD command/CLK for subcode.
37	O-WRC	O	CD read/write control output.
38	O-DATA	O	Data output to M62349FP.
39	O-CD LED	O	LED ON/OFF control output for the CD function.
40	O-TU LED	O	LED ON/OFF control output for the TU function.
41	O-TA LED	O	LED ON/OFF control output for the TA function. (Not connected)

Pin No.	Pin Name	I/O	Description
42	NC	—	Not connected.
43	$\overline{\text{SEG DP}}$	O	SEG DP control.
44	$\overline{\text{SEG A}}$	O	SEG A control.
45	$\overline{\text{SEG B}}$	O	SEG B control.
46	$\overline{\text{SEG C}}$	O	SEG C control.
47	$\overline{\text{SEG D}}$	O	SEG D control.
48	NC	—	Not connected.

# MECHANICAL PARTS LIST 1/1

DESCRIPTIONで判断できない物は "REFERENCE NAME LIST" を参照してください。  
If can't understand for Description please kindly refer to "REFERENCE NAME LIST".

REF.NO	PART.NO.	KANRI NO.	DESCRIPTION	REF.NO	PART.NO.	KANRI NO.	DESCRIPTION
1	8A-CDA-062-010		WINDOW,CASS D	34	8A-CDA-027-110		KEY,PAUSE
2	87-B00-010-010		BADGE,AIWA 30.5-5.2 S 2.5L	35	8A-CDA-026-110		KEY,STOP
3	8A-CDA-003-110		LID,CASS	36	8A-CDA-025-110		KEY,FF
4	8A-CDA-212-010		SPR-T,CASS	37	8A-CDA-024-110		KEY,REW
5	8A-CDA-042-010		WINDOW,LED LOW LH	38	8A-CDA-023-110		KEY,PLAY
6	8A-CDA-036-110		CABI ASSY,FRONT LOW EZ<GSC>	39	8A-CDA-022-110		KEY,REC
6	8A-CDA-177-110		CABI ASSY,FRONT V<VSC>	40	8A-CDA-221-010		SPR-P,REC
7	8A-CDA-206-010		HLDL,SPKR	41	8A-CDA-220-010		PLATE,REC
8	8A-CDA-059-110		KNOB,SL BAND EZ	42	8A-CDA-021-110		KNOB,RTRY TU
9	8A-CDA-045-010		WINDOW,TU EZ<GSC>	43	8A-CDA-013-010		POINTER,TU
9	8A-CDA-178-110		WINDOW,TU V<VSC>	44	8A-CDA-201-110		HLDL,TU
10	8A-CDA-007-010		LENS,LED	45	8A-CDA-216-110		GEAR,TU B
11	8A-CDA-019-110		KEY,VOL	46	8A-CDA-203-110		GUIDE,GEAR
12	8A-CDA-061-210		LID,CD D	47	8A-CDA-202-110		GEAR,RELAY
13	8A-CDA-213-010		COVER, CHUCK	48	8A-CDA-215-110		DRUM,TU
14	87-036-368-010		MAGNET	49	8A-CDA-037-110		CABI,REAR LOW
15	8A-CDA-207-110		HLDL,CHUCK	50	8A-CDA-005-110		LID,BATT
16	8A-CDA-150-010		BASE,CHUCK F/M	51	8Z-CD5-634-010		COVER,AC SOCKET
17	88-CD9-211-210		RING,CHUCK	54	8A-CDA-633-010		CONN ASSY,4P SP
18	8A-CDA-620-010		FF-CABLE,16P FR-MAIN	57	87-A60-178-010		JACK,AC E W/SW
19	8A-CDA-208-110		HLDL,LED	59	8A-CDA-612-010		PT,E 2.5W
20	8A-CDA-622-010		FF-CABLE,8P CD-FR	60	8A-CH4-682-010		SPKR,10- 70HM
21	8A-CDA-016-110		KEY,CD	61	88-CD6-661-010		HLDL,BAR ANT.
22	87-063-165-010		OIL-DMPR 150	A	87-721-096-410		QT2+3-10 GLD
23	8A-CDA-017-110		KEY,MODE	B	87-751-104-410		VT2+3-30
24	88-CH6-220-010		CUSHION,CD A	C	8A-CK4-223-010		S-SCREW,CD
25	8A-CDA-621-010		FF-CABLE,16P CD-RF	D	87-751-097-410		SCREW 3X12
26	8A-CDA-012-110		CHAS,CD	E	87-751-076-410		SCREW 2.6-12
27	87-036-389-010		SW,PUSH LOCK	F	8A-CDA-222-010		S-SCREW,CASS+2.6-4
28	8A-CDA-211-010		SPR-T,CD	G	87-253-033-110		SCREW,U+2-4
29	8A-CDA-010-210		HANDL,ARM	H	87-253-097-410		U+3-12 BLK
30	8A-CDA-011-110		HANDL,COVER	I	87-261-073-410		V+2.6-6
31	87-NF8-220-010		DMPR,150	J	87-751-096-410		VT2+3-10 GLD
32	87-A91-857-010		ANT,ROD 5SEC709	K	87-723-074-410		QT2+2.6-8 W/O SLOT BLK
33	8Z-CDB-169-010		PANEL,CD SANYO				

Note: No.52, 53, 55, 56 & 58 is not used.

## COLOR NAME TABLE

Basic color symbol	Color	Basic color symbol	Color	Basic color symbol	Color
B	Black	C	Cream	D	Orange
G	Green	H	Gray	L	Blue
LT	Transparent Blue	N	Gold	P	Pink
R	Red	S	Silver	ST	Titan Silver
T	Brown	V	Violet	W	White
WT	Transparent White	Y	Yellow	YT	Transparent Yellow
LM	Metallic Blue	LL	Light Blue	GT	Transparent Green
LD	Dark Blue	DT	Transparent Orange	GM	Metallic Green
YM	Metallic Yellow	DM	Metallic Orange	PT	Transparent Pink



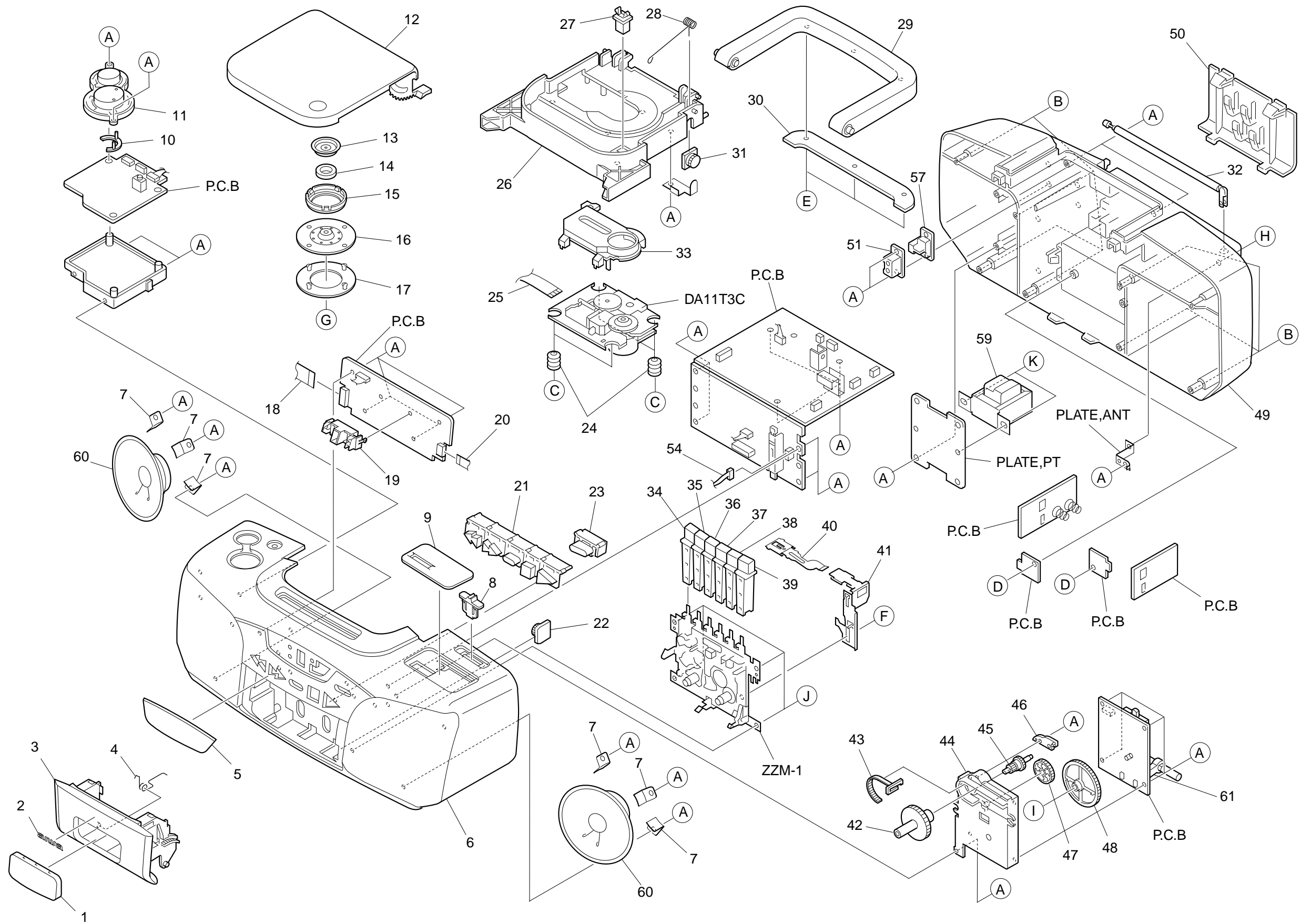

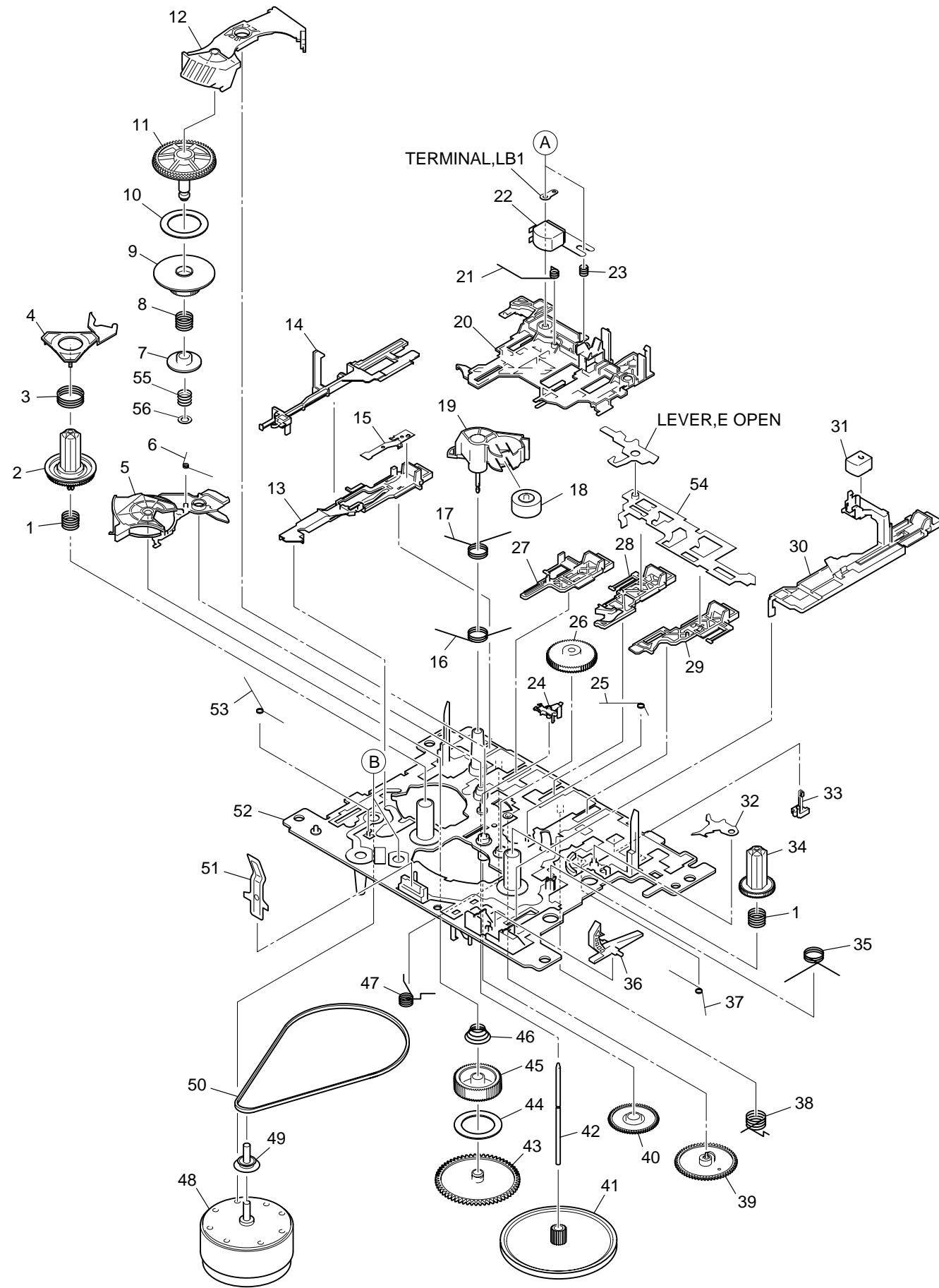

TAPE MECHANISM PARTS LIST 1/1

DESCRIPTIONで判断できない物は "REFERENCE NAME LIST" を参照してください。  
 If can't understand for Description please kindly refer to "REFERENCE NAME LIST".

REF. NO	PART NO.	KANRI NO.	DESCRIPTION	REF. NO	PART NO.	KANRI NO.	DESCRIPTION
1	8Z-ZM1-254-210		SPR-C, REEL R	31	87-A91-533-010		HEAD, EH PH-K380
2	8Z-ZM1-225-110		GEAR, REEL R	32	8Z-ZM1-215-010		LEVER, REC LOCK
3	8Z-ZM1-253-110		SPR-C, AUTO SENSOR	33	87-A91-492-010		SW, LEAF MSW18560
4	8Z-ZM1-217-110		LEVER, AUTO SENSOR	34	8Z-ZM1-226-010		GEAR, REEL L
5	8Z-ZM1-212-110		LEVER, T-UP	35	8Z-ZM1-241-010		SPR-T, PLAY
6	8Z-ZM1-245-010		SPR-T, AUTO	36	8Z-ZM1-220-010		LEVER, REC SENSOR
7	8Z-ZM1-236-010		CLR, SLIP FF/REW	37	8Z-ZM1-249-010		SPR-T, FR
8	8Z-ZM1-252-010		SPR-C, FF/REW	38	8Z-ZM1-242-110		SPR-T, FF/REW
9	8Z-ZM1-230-010		GEAR, SLIP FF/REW A	39	8Z-ZM1-229-010		GEAR, CAM
10	8Z-ZM1-266-010		FELT, FF/REW	40	8Z-ZM1-232-010		GEAR, IDL FF/REW
11	8Z-ZM1-231-010		GEAR, SLIP FF/REW B	41	8Z-ZM1-234-010		FLY-WHL, ZZM-1
12	8Z-ZM1-213-010		LEVER, FF/REW	42	8Z-ZM1-267-010		SHAFT, CAPSTAN 2
13	8Z-ZM1-209-110		LEVER, PAUSE	43	8Z-ZM1-228-010		GEAR, SLIP T-UP B
14	8Z-ZM1-222-010		LEVER, E-LOCK M	44	8Z-ZM1-265-010		FELT, T-UP
15	8Z-ZM1-256-010		SPR-P, PAUSE	45	8Z-ZM1-227-010		GEAR, SLIP T-UP A
16	8Z-ZM1-244-010		SPR-T, T-UP	46	8Z-ZM1-251-110		SPR-C, T-UP SLIP
17	8Z-ZM1-247-210		SPR-T, PINCH	47	8Z-ZM1-243-210		SPR-T, STOP/PAUSE
18	8Z-ZM1-261-110		ROLLER ASSY, PINCH	48	87-A91-531-010		MOT, MS15C2L
19	8Z-ZM1-221-010		LEVER, PINCH	49	8Z-ZM1-271-010		PULLEY, MOT ZZM-1
20	8Z-ZM1-205-210		LEVER, PLAY	50	8Z-ZM1-264-010		BELT, MAIN S
21	8Z-ZM1-248-010		SPR-T, BRG	51	8Z-ZM1-260-010		SPR-P, CASSETTE
22	87-A90-403-110		HEAD, RPH MS15R	52	8Z-ZM1-201-310		CHAS ASSY, ZZM-1
23	84-ZM2-227-310		SPR-C, AZIMUTH	53	8Z-ZM1-255-110		SPR-T, E-LOCK
24	8Z-ZM1-216-010		LEVER, AUTO	54	8Z-ZM1-214-010		LEVER, LOCK
25	8Z-ZM1-246-010		SPR-T, AUTO 2	55	8Z-ZM1-257-110		SPR-C, F/R
26	8Z-ZM1-233-010		GEAR, IDL REW	56	8Z-ZM1-275-010		W-L, 1.47-4-0.25
27	8Z-ZM1-208-010		LEVER, STOP	A	84-ZM2-242-010		S-SCREW, AZ1-2-6.4
28	8Z-ZM1-207-010		LEVER, FF	B	8Z-ZM1-270-110		V+2.6 ZZM-1
29	8Z-ZM1-206-010		LEVER, REW				
30	8Z-ZM1-211-110		LEVER, REC 2				

# CD MECHANISM EXPLODED VIEW 1/1

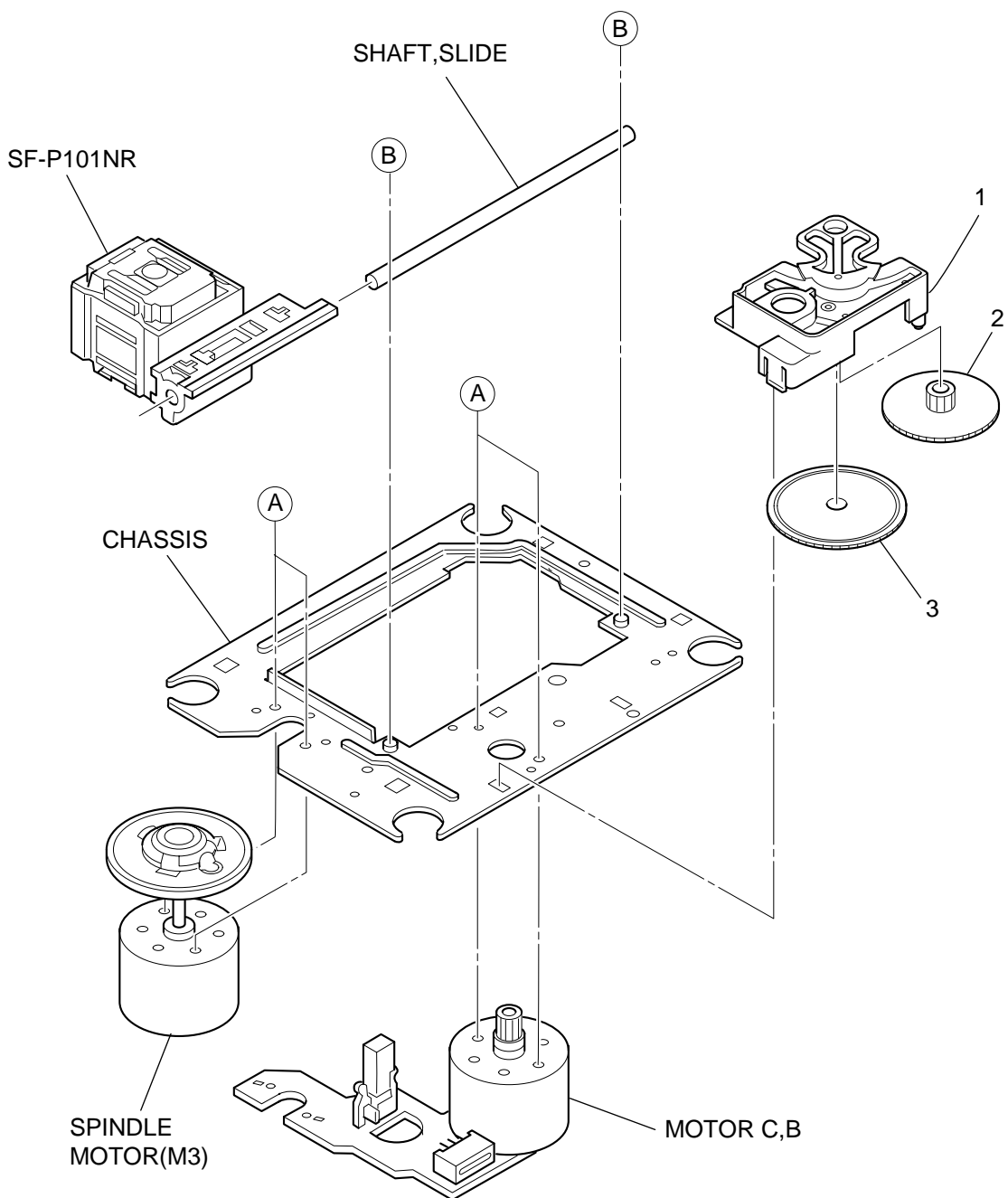

## CD MECHANISM PARTS LIST 1/1

DESCRIPTIONで判断できない物は "REFERENCE NAME LIST" を参照してください。  
 If can't understand for Description please kindly refer to "REFERENCE NAME LIST".

REF. NO	PART NO.	KANRI NO.	DESCRIPTION
1	S2-121-A28-400		COVER GEAR
2	S2-511-A21-000		GEAR MIDDLE
3	S2-511-A21-100		GEAR, DRIVE
A	S1-PN2-03R-OSE		SCR PAN PCS 2-3
B	87-261-073-410		SCR S-TPG FLT 2.6-6
ALL	M8-ZZK-E90-070		DA11T3C

アイワ株式会社 〒110-8710 東京都台東区池之端1-2-11 ☎03(3827)3111 (代表)  
**AIWA CO.,LTD.** 2-11, IKENOHATA 1-CHOME, TAITO-KU, TOKYO 110, JAPAN TEL:03 (3827) 3111