

Wide Ranging dB Meter

Using a THAT4301 as a 2:1 feedback compressor effectively doubles the dynamic range of the THAT4301's RMS detector by compressing the VCA's 120dB dynamic range through the 80 dB dynamic range of the level detector. This results in a true RMS meter with ~120 dB dynamic range and an output linear in dB, suitable for all but the most demanding metering applications.

Basic Topology

Figure 1 shows the basic topology of a feedback compressor. The analysis of this circuit is not very intuitive in the linear domain, but greatly simplified when working in the log domain.

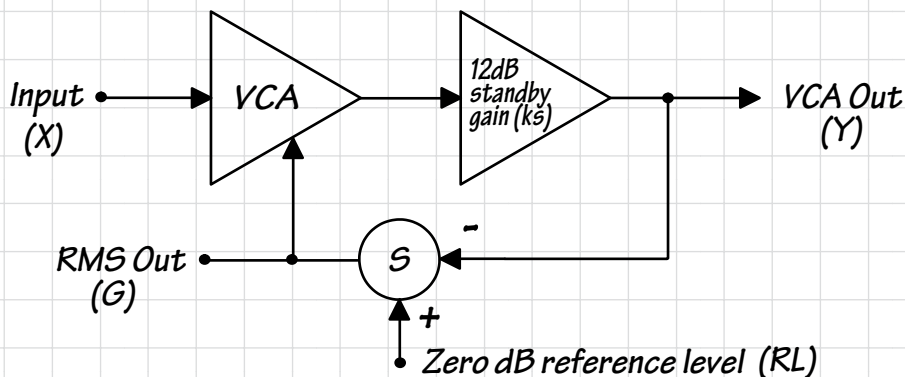

Figure 1: Signal flow diagram for a feedback compressor

First, let us make a few assumptions and clarifications:

- X is the VCA input, and we will let its full scale be 20 dBu.
- ks is the stand-by gain, independent of the control port, taken in the VCA. We will set this value at 12 dB.
- Y is the VCA output, measured in dBu, and is also the RMS detector input.
- RL is the zero dB reference level of the RMS detector. This is the input level which results in zero volts out of the RMS detector, and as a result, sets the VCA current gain to unity. At the zero dB reference level, the currents in and out of the VCA will be equal or matched, thus the term level match. We will set this value at -20 dB.
- G is the current gain of the VCA, in dB, as controlled via its control port. It is also a direct function of the output of the level detector.

Since we are working in the log domain, we can say

$$Y = X + ks + G \quad (\text{eqn. 1})$$

which is the same as multiplying these terms in the linear domain. It is also clear that

$$G = RL - Y \quad (\text{eqn. 2})$$

This sign convention results from our use of the negative control port of the VCA.

Substituting for G ,

$$Y = X + ks - Y + RL, \text{ or } Y = \frac{X + ks + RL}{2} \quad (\text{eqn. 3})$$

Wide Ranging dB Meter

VCA Input in dBu	VCA Output in dBu	VCA current gain in dB
20	6	-26
10	1	-21
0	-4	-16
-10	-9	-11
-20	-14	-6
-30	-19	-1
-40	-24	4
-50	-29	9
-60	-34	14
-70	-39	19
-80	-44	24
-90	-49	29
-100	-54	34

Figure 2: Input and output levels of the VCA for a feedback compressor, and the VCA current gain

The table in Figure 2 shows the resulting VCA output, calculated with equation 3, and the resulting VCA gain, calculated with equation 2, that corresponds to the given VCA input shown in the first column. Note that while the dynamic range of the input is $20 - (-100) = 120\text{dB}$, the dynamic range of the VCA output is only $34 - (-26) = 60\text{dB}$, thus demonstrating the 2:1 compressor action. The gain range of $+34\text{dB}$ to -26dB is well within the VCA's preferred operating range.

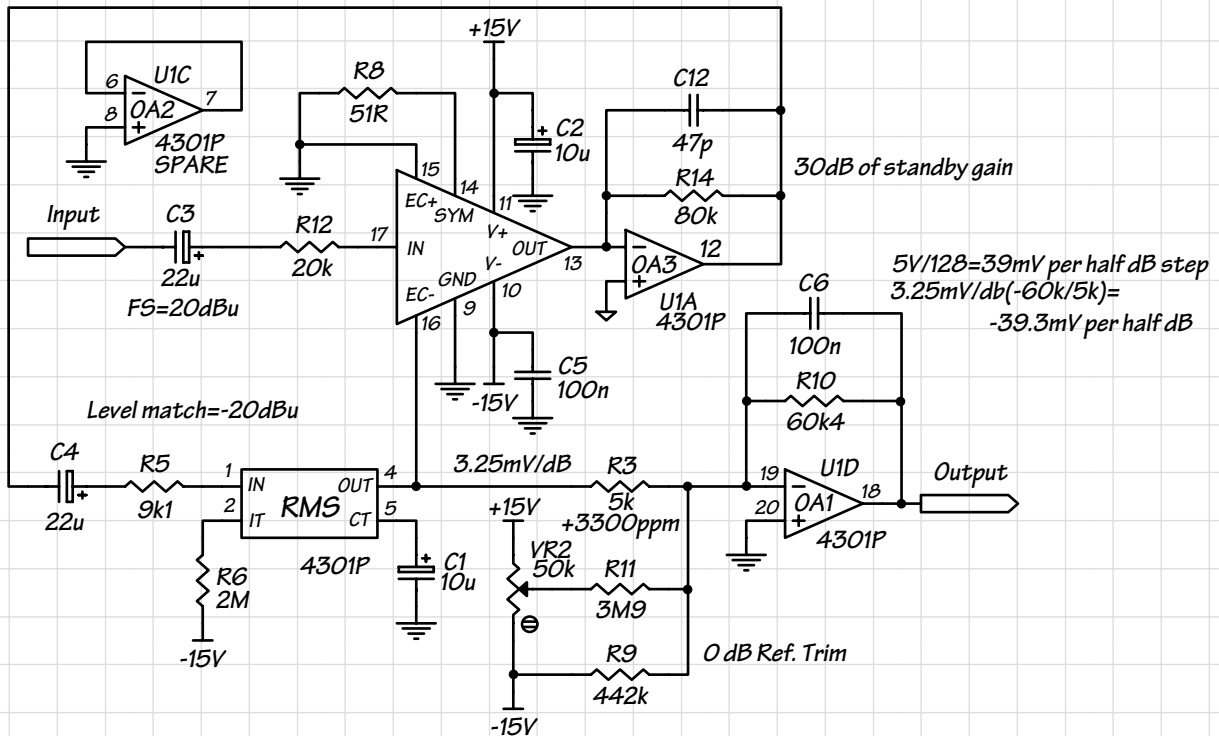

Figure 3: Schematic of wide ranging RMS level meter

Wide Ranging dB Meter

Application Circuit

The circuit in Figure 3 shows a basic implementation of the wide ranging RMS level meter. This circuit consists of a VCA with 12dB of stand-by gain, an RMS detector connected to the VCA in a feedback compressor topology, and a RMS output scaling amplifier. This circuit is designed to have a full scale input of 20dBu and an output that is scaled to transform a -100 to 20 dBu into a signal that swings 0-5 V, which is compatible with many low cost 8-bit ADCs.

The VCA with stand-by gain

This circuit accepts a full scale signal of 20 dBu. If the source is not that high, one can configure the spare op-amp, U1C, as an amplifier to scale the signal appropriately. In most applications, log-antilog VCAs are used with zero dB of stand-by gain; that is, when the difference between the control ports is zero, the total voltage gain is one. In this design it is beneficial to use stand-by gain to skew the compressor's gain requirements. If not, then the maximum VCA gain required would be +40 dB when the VCA input dropped to -100 dBu, which the VCA can provide, but at the expense of bandwidth.

Other VCA issues

C12 helps OA3 maintain stability against the high output capacitance of the VCA. This capacitor, in conjunction with R14, set the bandwidth at ~56 kHz. Since this is a measurement application, we have not included a means for adjusting the VCA symmetry. The worst case distortion without trimming symmetry is about 0.7% THD, and this will not result in a significant error. C2 should be of value comparable to that of C1. Its purpose is to provide a path for the peak return currents of C1, which can be quite high.

The RMS detector

THAT Corporations RMS level detectors derive the true RMS level of an audio signal by:

1. Converting the input into a current and full wave rectifying it.
2. Logging and doubling this current waveform, which in the log domain, is equivalent to squaring.
3. Averaging the result in a log-domain filter, which results in the mean of that signal.

Thus, THAT RMS detectors perform the mean and the square portion of root-mean-square. The square-root portion of that function is performed implicitly at the logarithmic control port of the VCA.

The two design criteria a designer needs to worry about are the RMS timing and the zero dB reference level. Timing determines the attack and release rates, which are linked in these level detectors, and the zero dB reference level determines the input level where the RMS output will be zero, thus setting the VCA to zero dB of current gain.

Before proceeding, it is useful to enumerate some of the constants in this design:

$V_{CC} = +15V$ and $V_{SS} = -15V$

$I_T = 7.5 \mu A$ is the recommended value for I_T

$k = 6.5 \text{ mV/dB}$ is the room temperature gain control constant for the VCA and the RMS detector.

Wide Ranging dB Meter

Timing

In this design, the timing current is set to the recommended value by R6:

$$R6 = \frac{-V_{SS}}{I_T} = \frac{15V}{7.5\mu A} = 2M\Omega$$

The level detector's log domain filter consists of this capacitor, and a diode internal to the IC. The equivalent resistance of this diode can be determined by the equation:

$$r_d = \frac{1}{g_m} = \frac{V_T}{I_d}$$

Thus,

$$r_d = \frac{V_T}{I_d} \cong 3.499k\Omega, \text{ at } 270C$$

If we set the corner frequency to $f_c \cong 5Hz$, which is an adequate low frequency corner for most audio signals, we may then calculate the time constant

$$\tau = \frac{1}{2 \times \pi \times f_c} = \frac{1}{2 \times \pi \times 5Hz} \cong 32mS$$

Using these identities, we can calculate C1: $C1 = \frac{r_d}{\tau} = \frac{32mS}{3.466k\Omega} = 9.2\mu F = 10\mu F$

Zero dB reference level

The zero dB reference level is set by the input resistor of the RMS detector, and the detector's zero dB input current. To set this level, one must first determine the zero dB input current.

$$I_{ZERO\ dB} = \sqrt{9.6\mu A \times I_T} = \sqrt{9.6\mu A \times 7.5\mu A}$$

which results in $I_{ZERO\ dB} = 8.5\mu A$

As stated earlier, we chose -20dBu as the zero dB reference level. This corresponds to:

$$V_{ZERO\ dB} = 0.775 \times 10^{\left(\frac{-20dBu}{20}\right)} = 77.5\ mV$$

Using this value, we can calculate the appropriate value for R5:

$$R5 = \frac{V_{ZERO\ dB}}{I_{ZERO\ dB}} = \frac{77.5mV}{8.5\mu A} \cong 9.1k\Omega$$

Output buffering and scaling

The gain control constant for the THAT4301 is 6.5mV/dB, but due to the 2:1 compressor action, the change at the output of the RMS detector is only 3.25mV/dB. This voltage is also proportional to absolute temperature. As a result, it is often useful to apply scaling and temperature compensation to this signal.

There is a wide variety of 8 bit DACs available today, some with a per channel cost below \$0.35. In their simplest configuration, these devices operate off +5V, and use a filtered version of their supply as their reference voltage. If one wishes to measure the wide ranging meter's output to within $\pm 1/2$ dB, the RMS detector's output needs to be scaled to

$$\frac{5V}{256\ bits} \times \frac{2\ bits}{dB} = 0.039 \frac{V}{dB}$$

Wide Ranging dB Meter

In this design, OA1 is configured as an inverting summing amplifier. R3 should be a +3300 ppm/°C resistor, as this will correctly compensate the temperature coefficient of the level detector's gain control constant (the temperature coefficient of the VCA's gain control constant is compensated for by the RMS detector, and as such, this correction should be made after the connection to the control port). We have chosen a 5 kΩ resistor for R3, since this value is readily available from KOA Speer and can be driven by the output of the RMS detector.

$$A_V = \frac{5V}{(120dB \times 3.25 \frac{mV}{dB})} = 12.8$$

Thus, $R10 = 12.8 \times 5 \text{ k}\Omega = 64.9 \text{ k}\Omega$

(Note: For simplicity, we have failed to show the sign of the gain, since this can easily be accommodated once the signal is converted into binary form. It does mean that zero volts corresponds to 20 dBu, and -100 dBu is near 5V. If this becomes an issue, OA2 can be used to invert the polarity.)

The 5 kΩ resistor implies that in the summing node, the current that represents one dB will be:

$$i_{1dB} = \frac{0.00325 \frac{mV}{dB}}{5 \text{ k}\Omega} = 0.65 \frac{\mu A}{dB}$$

We can use the results of the equation above to calculate a zero offset that will make -100 dBu to -20 dBu proportional to 5V to 0V. As stated previously, the zero dB reference level point is at -20 dBu at the RMS, but there is also 12 dB of voltage gain in the VCA, and the zero dB reference level relative to the VCA's input is -20 dBu - 12 dB = -32 dBu. When you account for the 20 dBu full scale, the output of the RMS detector is positive for 52 dB above zero dB reference level, and this will result in a corresponding negative excursion of OA1. R9 is used to provide an offset that will eliminate this excursion:

$$R9 = \frac{15V}{(52dB \times \frac{0.65\mu A}{dB})} \cong 443 \text{ k}\Omega$$

R11 provides ±6 dB of adjustment, to accommodate the ±3dB tolerance on the zero dB reference level of the THAT4301, and for other component and power supply tolerances.

$$R11 = \frac{15V}{(6dB \times \frac{0.65\mu A}{dB})} \cong 3.9 \text{ M}\Omega$$

Conclusion

Using the THAT4301 as a wide ranging meter provides a simple and convenient way to convert audio signals with up to a 120 dB dynamic range into a high level signal that can be read with ½dB resolution by an inexpensive, 8-bit DAC.