

A REAL-TIME octave spectrum analyzer is an invaluable audio test instrument for anyone who wishes to adjust an equalizer to compensate for room or system deficiencies, evaluate and compare loudspeakers, test a hi-fi system's response, and perform other types of acoustic analyses.

Usually, such a device is very expensive. The analyzer described here, however, can be built at reasonable cost, is simple to operate, and when powered by its internal battery, can be hand-held while in use.

The instrument passes the audio output of its internal microphone capsule through 10 octave-spaced bandpass filters and displays the levels in the various bands on a 10 x 7 LED matrix. Decay time of the display can be short, long, or indefinite, depending on the setting of a switch. In addition, the 31-Hz channel can be switched to read out the average level of the total audio signal, allowing the analyzer to be used as a sound-level meter.

Circuit Operation. As shown in Fig. 1, the audio input at J1 is fed to a buffer in IC1A. The gain (11.8) of this stage is set by the ratio of R5 + R6 to R5. After amplification, the signal forms the common audio input to 10 two-pole bandpass filters as shown in Fig. 2. The center frequencies of the filters were chosen to match the ISO standards for 10-band octave equalizers, making the analyzer as useful as possible in consumer applications. Center frequencies are 31.25, 62.5, 125, 250, 500, 1000, 2000, 4000, 8000, and 16,000 Hz. To produce at least a 15-dB attenuation of adjacent octave center frequencies, a Q of 3.75 was chosen. This produces a clean display while retaining the excellent selectivity for measurement accuracy. The gain of each filter is -2.86 or about 9 dB.

The bandpass output of the filter is rectified (half-wave) by a diode (Fig. 2) and averaged by R_F, C_C, R63, R64, and R65 (Fig. 3). The average network is peak-weighted with the attack characteristics determined by R_F and C_C. The specific value of the attack time constant varies between the filters according to the bandpass center frequency and the values of the audio energy present in that region. The decay time constants are selected by S2B (Fig. 3). The FAST

BY JOHN PFEIFFER and WILLIAM EPPLER

BUILD A

Hand-Held LED Spectrum Analyzer

*Real-time octave
spectrum analyzer
features ten
bands for
performing a
variety of
useful audio
tests and
adjustments*

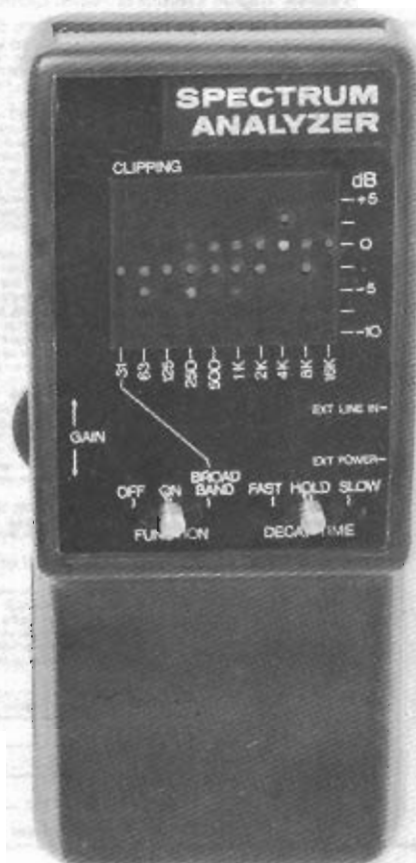

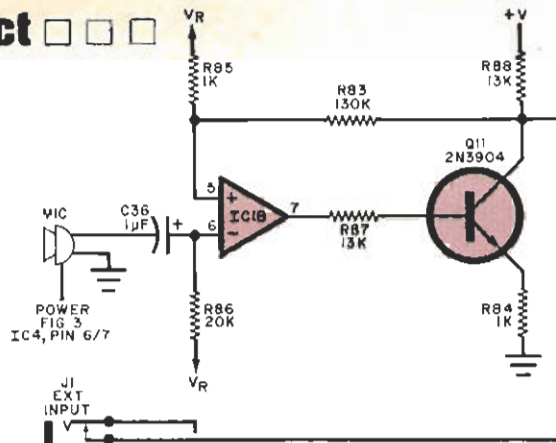

Fig. 1. Input to the analyzer can be directly through J1 or via a microphone with a preamp.

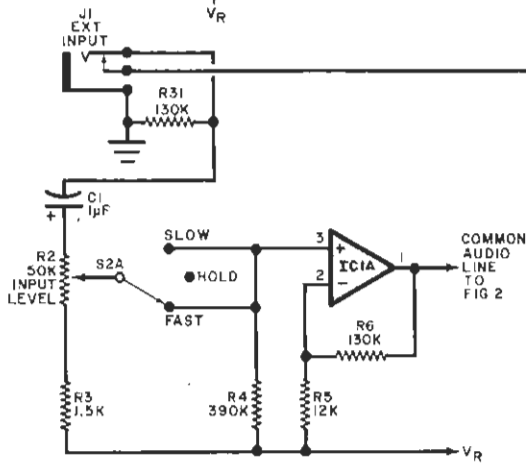
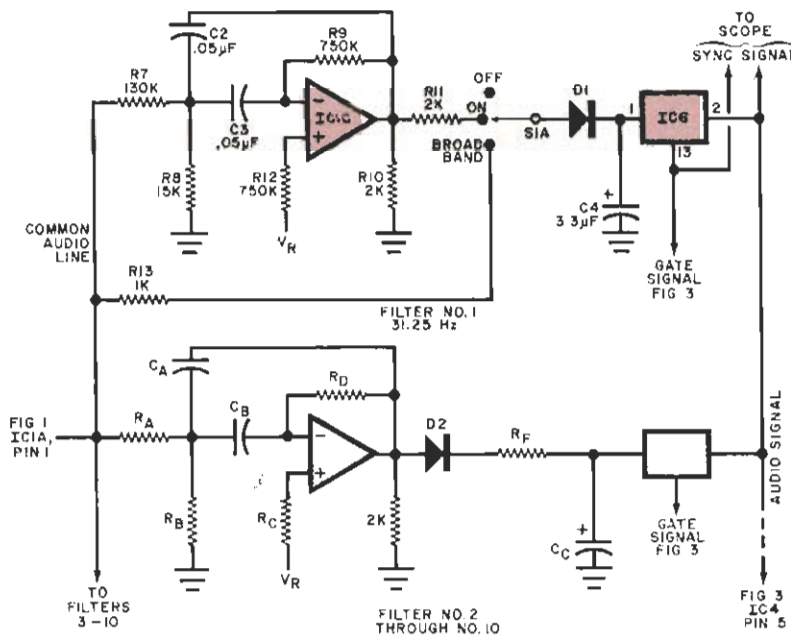

Fig. 2. Incoming audio goes to 10 bandpass filters. Values of components for filters 2 through 10 are given in table below.



Filter	Frequency (Hz)	R _A *	R _B	R _C	R _D	R _F	C _A **	C _B	C _C
2	62.5	68	7.5	390	390	2	0.05	0.05	2.2
3	125	36	3.9	200	200	2	0.047	0.05	2.2
4	250	18	2	0	100	2	0.047	0.05	2.2
5	500	8.2	0.91	0	47	2	0.05	0.05	1
6	1,000	20	1	0	75	2	0.01	0.033	1
7	2,000	11	1.2	0	62	1	0.01	0.01	1
8	4,000	11	1.5	0	75	1	0.0047	0.0033	1
9	8,000	12	1.2	0	68	0.75	0.0022	0.0022	1
10	16,000	13	1.2	0	75	0.33	0.001	0.001	1

*Resistances in kilohms.
**Capacitances in microfarads.

PARTS LIST

- B1—8 AA cells
 - C1, C16, C19, C22, C25, C28, C31, C36—1-µF, 16-V low-leakage radial-lead electrolytic
 - C2, C3, C5, C6, C9, C12, C14, C15—0.05-µF, 100-V 5% Mylar
 - C4—3.3-µF, 16-V low-leakage radial-lead electrolytic
 - C7, C10, C13—2.2-µF, 16-V low-leakage, radial-lead electrolytic
 - C8, C11—0.047-µF, 100-V 5% Mylar
 - C17, C20, C21—0.01-µF, 100-V 5% Mylar
 - C18—0.033-µF, 100-V 5% Mylar
 - C23—0.0047-µF, 100-V 5% Mylar
 - C24—0.0033-µF, 100-V 5% Mylar
 - C26, C27—0.0022-µF, 100-V 5% Mylar
 - C29, C30, C34—0.001-µF, 100-V 5% Mylar
 - C32, C33—33-µF, 6-V radial-lead electrolytic
 - C35—33-µF, 16-V radial-lead electrolytic
 - D1 through D10—1N4148
 - DISP1, DISP2—5 x 7 LED matrix (IEE Type LRT1057R) or 70 subminiature red LEDs.
 - IC1, IC2, IC3—LM324 quad op amp
 - IC4—LM3915 LED display driver (National)
 - IC5—CD4017AE CMOS counter
 - IC6, IC7, IC8—CD4016AE CMOS quad analog switch
 - J1—Miniature phone jack (Radio Shack #274-296)
 - J2—Subminiature phone jack (Radio Shack #274-292)
 - LED1—Subminiature red light emitting diode
 - MIC—Electret condenser microphone element (Radio Shack #270-092).
 - Q1 through Q11—2N3904 or equivalent
- Unless otherwise noted, the following are 1/4-W, 5% resistors:
- R1, R6, R7, R68, R83—130,000 ohms
 - R2—50,000-ohm audio-taper miniature thumbwheel potentiometer
 - R3, R47—1500 ohms
 - R4, R16, R19, R63, R66—390,000 ohms
 - R5, R51—12,000 ohms
 - R8—15,000 ohms
 - R9, R12—750,000 ohms
 - R10, R11, R17, R18, R23, R24, R27, R29, R30, R34, R35, R39, R40, R44, R49, R54, R59—2000 ohms
 - R13, R37, R45, R50, R84, R85—1000 ohms
 - R14, R53—68,000 ohms
 - R15—7500 ohms
 - R20—36,000 ohms
 - R21—3900 ohms
 - R22, R25—200,000 ohms
 - R26—18,000 ohms
 - R28—100,000 ohms

mode is useful for displaying the spectrum of speech, music, and other rapidly varying signals. SLOW is used for measuring noise and frequency response. HOLD removes the input signal and defeats the decay network to hold any display condition for several seconds, so the user can record data, change measurement position, etc.

To save cost and space, the LED display matrix and display driver IC4 are multiplexed among the 10 bandpass filters as shown in Fig. 3. The outputs of IC5, a CMOS decade counter, are normally low and go high only at their respective decoded time slots and remain

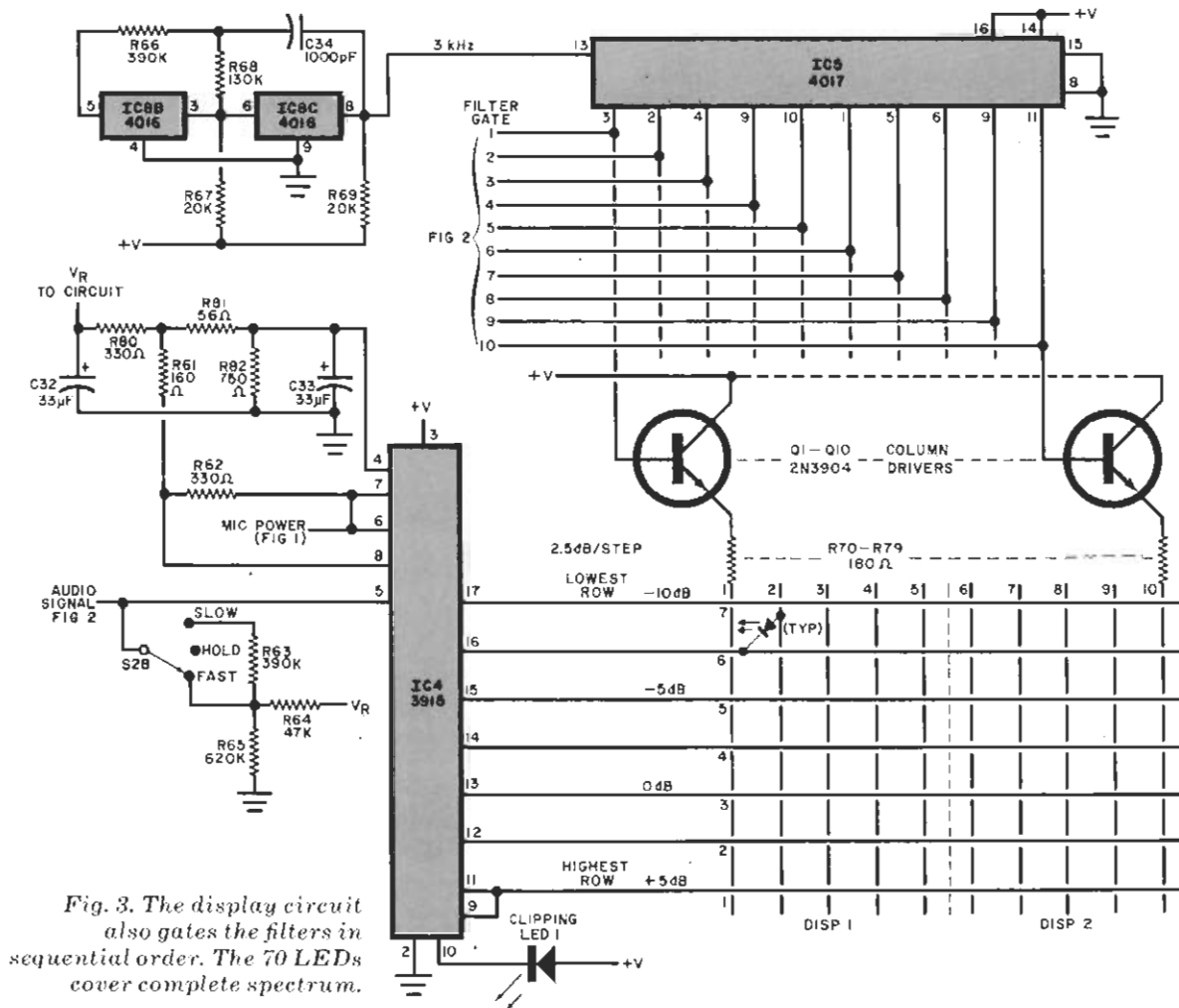

Fig. 3. The display circuit also gates the filters in sequential order. The 70 LEDs cover complete spectrum.

- R31—8200 ohms
- R32—910 ohms
- R33, R64—47,000 ohms
- R36, R67, R69, R86—20,000 ohms
- R38, R48, R58—75,000 ohms
- R41, R46—11,000 ohms
- R42, R52, R57—1200 ohms
- R43—62,000 ohms
- R55, R82—750 ohms
- R56, R87, R88—13,000 ohms
- R60, R62, R80—330 ohms

- R61—160 ohms
 - R65—620,000 ohms
 - R70 through R79—180 ohms
 - R81—56 ohms
 - S1, S2—Double-pole, triple-throw toggle switch
 - Misc.—Suitable enclosure, hardware, hookup wire, battery box (2) (Radio Shack 270-391), double-sided foam tape, external power source (8-15 V dc at 100 mA), etc.
- Note: The following are available from Gold

Line Inc., P.O. Box 20, Redding, CT 06875 (203-938-2588); Complete Model ASA-10 kit including microphone, battery box, and custom-molded case for \$139. Also available separately: kit of parts excluding battery box, microphone, and case for \$109; set of etched and drilled circuit boards for \$18; case and microphone for \$30; pc boards, LED displays, and LM3915 for \$35. Connecticut residents add state sales tax.

high for one full clock period. This sequentially enables the LED matrix columns through buffers Q1 through Q10.

Two transmission gates in IC8 make up the counter clock, as shown in Fig. 3. For the values given, the oscillator frequency is approximately 3000 Hz (0.33 ms period). This frequency is not critical. Since the oscillator has active pull-down, the rise time is slow. Therefore, counter IC5 must be toggled on the falling edge of the clock. This is accomplished by connecting the normal clock input at pin 14 to high and toggling clock-enable input pin 13.

Decoded outputs from IC5 multiplex

the bandpass filter average networks to the input of the IC4 display drive through CMOS transmission gates located at the output of each filter network (Fig. 2). Since the decay network consisting of R63 through R65 is connected to any particular averaging capacitor (C_C) for one-tenth of the time and that interval is much smaller than the time constant of R64C_C, the effective decay resistance is 10 times greater than the actual circuit value.

In the HOLD mode, the reflected input impedance of IC4 is also 10 times greater, producing an almost negligible drift as a sample-and-hold circuit. By far, the

dominant factor in the HOLD mode is the leakage of the averaging capacitors. The decay rate in the 500-Hz channel, for example, in the FAST mode is $0.87 / (R64 \times 1 \mu\text{F})$ or about 18 dB/second. In the SLOW position, the rate is $0.87 / [(R63 + R64) \times 1 \mu\text{F}]$ or about 2 dB/second.

Integrated circuit IC4 is designed to sense analog voltage levels at its input and provide up to 10 individual current-regulated outputs. This allows direct LED interface for a logarithmic analog display with 3-dB/segment scaling. The IC contains its own adjustable reference and accurate 10-step voltage divider. Because of excellent on-chip matching,

Audio Project

display nonlinearity can be held to less than 1%. A single control-pin changes the display from dot to bar-graph.

In this analyzer, the dot mode was selected to minimize current requirements and provide a pleasing display. Only

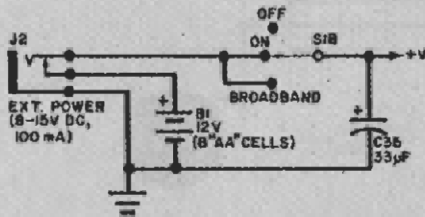

Fig. 4. Use power from internal batteries or external dc source.

seven of the available LED outputs are used, due to display matrix size. A clipping indicator LED is wired to IC4 at pin 10 to indicate an overrange condition. Resistors R70 through R79 reduce power dissipation in IC4.

Average current in each LED is 4 mA, and bias voltages remain constant for any supply potential between 8 and 15 volts dc. Step size also remains fixed so that calibration and LED brightness are independent of battery condition. The power source circuit for the analyzer is shown in Fig. 4.

Although IC4 has a 3-dB/step scale factor, the voltage drop across the signal rectifier diodes (D1 through D10) varies in a roughly logarithmic fashion with signal amplitude. This modifies the relationship of display increment to input level. Bias voltages and diode current have been set to make display increments of 2.5 dB/step.

In addition to controlling power to the

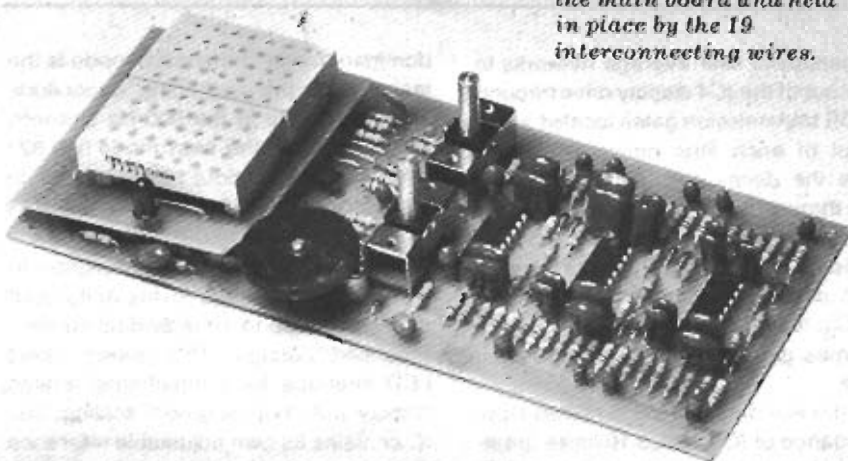

Photo of prototype shows how board with two display assemblies is mounted over the main board and held in place by the 19 interconnecting wires.

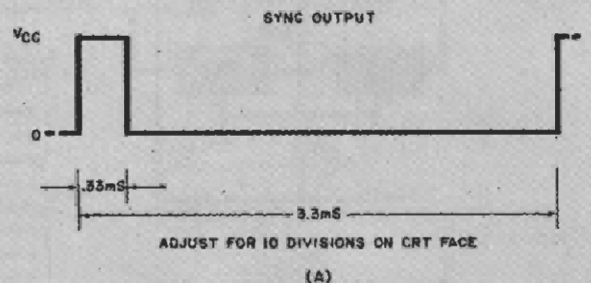
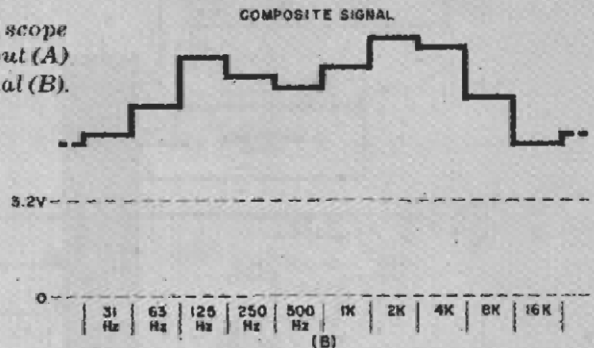

Fig. 5. Typical scope traces for sync output (A) and composite signal (B).



unit. S1, when set to BROADBAND, changes the function of the left-most display column from 31-Hz bandpass to peak-weighted broadband. This is useful for noise measurements and level display, but note should be taken of the 9-dB gain of the spectrum display relative to the broadband channel.

When EXT INPUT jack J1 is not used, a calibrated microphone is automatically connected to the input buffer (Fig. 1). The microphone preamplifier has a gain of 131. Transistor Q11 increases the gain/bandwidth product of the preamp.

SPECIFICATIONS

External Input

- Impedance: 33,000 ohms
- Gain to broadband display: 11.8 (21 dB) max. 0.34 (-9 dB) min.
- Input for clipping display: Broadband: 150 mV min. 3.8 V max. Spectrum: 57 mV min. 1.4 V max.

Microphone Input

- Impedance: 20,000 ohms
- Gain: 131 (42 dB)

Display

- Step increment: 2.5 dB \pm 1/2 dB
- Attack time/averaging window: 0.33 ms to 6.6 ms*
- Decay time (500 Hz channel): Fast: 18 dB/s Slow: 2.2 dB/s Hold: 10 mV/s

Scope Outputs

- Sync impedance: CMOS
- Composite impedance: High (use 10X probe)

Power Supply

- Voltage: 8 to 15 V dc unregulated
- Current: 80 mA max.
- *Depending on center frequency.

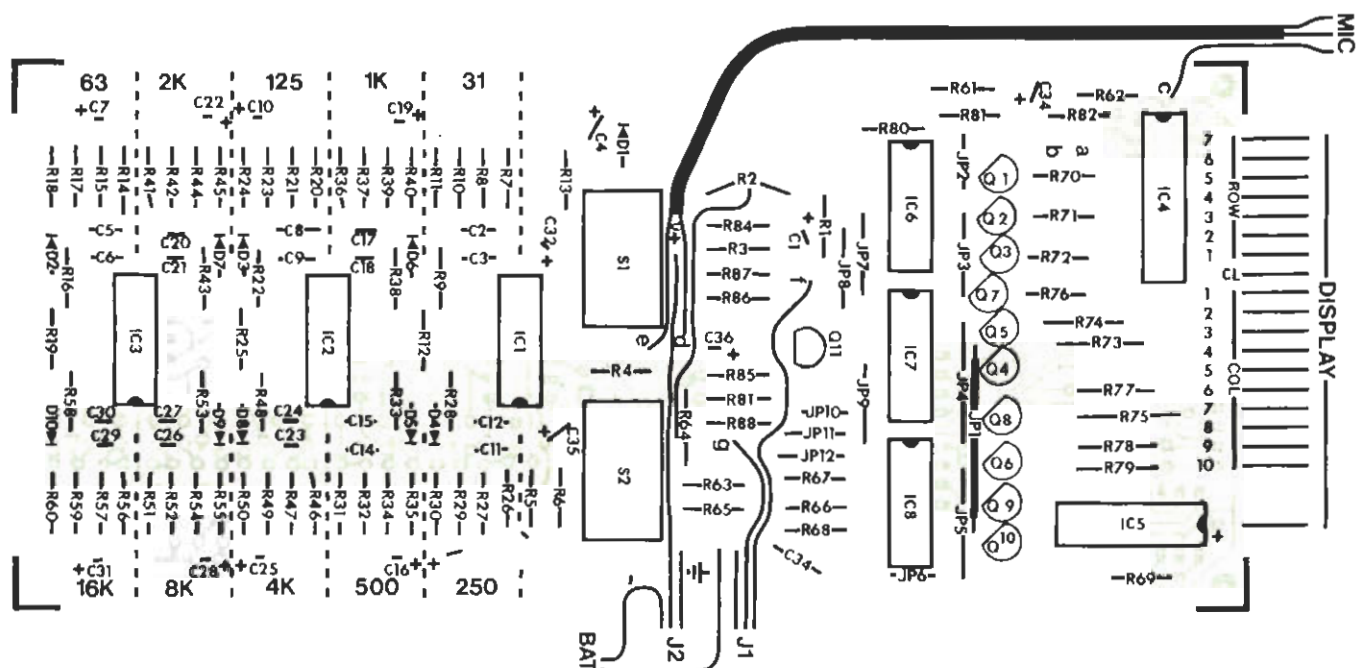
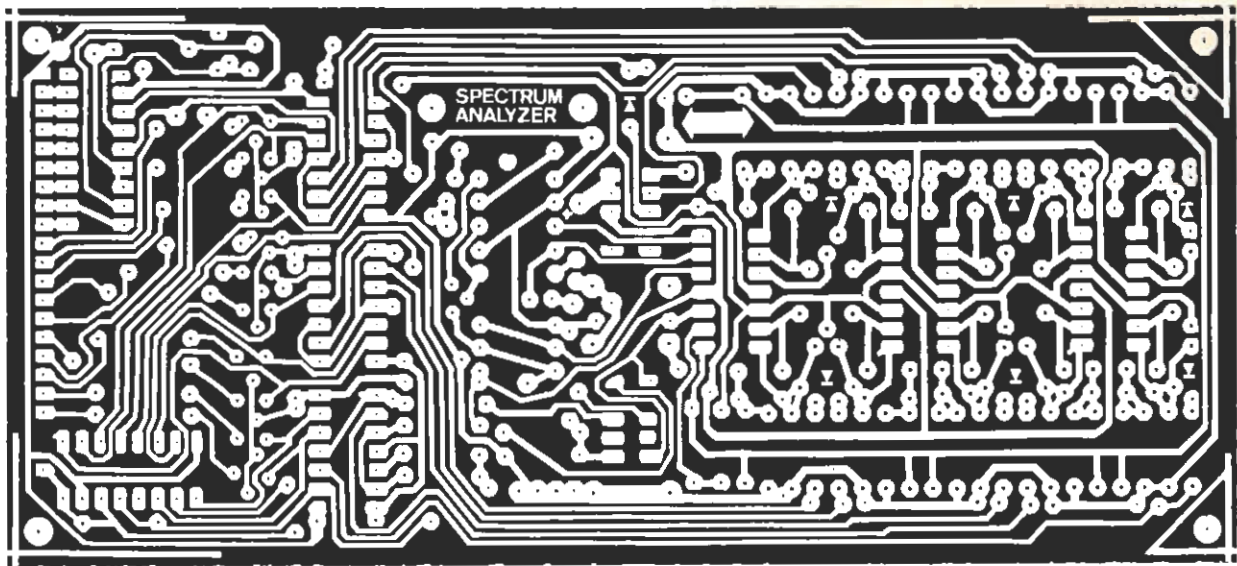

Fig. 6. Actual-size etching and drilling guide (above) and component layout for the main board of the analyzer.

An alternate display is provided by a scope signal as shown in Fig. 2. Connect the sync lead to the sync input of the scope and the signal lead to the scope's vertical input. The scope should be triggered on by the positive edge of the sync signal, and the sweep timebase should be adjusted for exactly 10 divisions between trigger edges. The resulting display will have a linear scale rather than the log scale of the LED display. A typical CRT display is shown in Fig. 5.

Construction. Owing to many components and high packing density, the use of printed circuit boards is essential. Etching and drilling guides and compo-

nent installation layouts for the main and display boards are shown in Figs. 6 and 7, respectively.

Proper orientation of diodes, ICs and polarized capacitors is critical. Also, use 5% tolerance polyester capacitors in the filters to insure accurate center frequency, gain, and Q. As discussed before, proper operation of the HOLD mode depends on the use of capacitors with very low leakage in the bandpass averaging networks. The use of tantalum or low-leakage aluminum electrolytics is urged.

Since the display board is to be mounted very close to the components at the top of the main board, IC sockets cannot be used for IC4 through IC8.

Transistors Q1 through Q10 must be mounted with as little clearance as possible between the bottoms of their cases and the top of the main pc board.

Potentiometer R2 should be mounted on 3/16" spacers with 2-56 small-pattern hardware. The outer terminals of the potentiometer can be connected directly to the board with bare wire. The center lug then connects as indicated in Fig. 6 with a 2" insulated wire.

When assembling the display board, solder the displays directly to the board, noting proper orientation. Solder the clipping indicator LED so that it is flush with the top of the displays.

Once the two board assemblies are

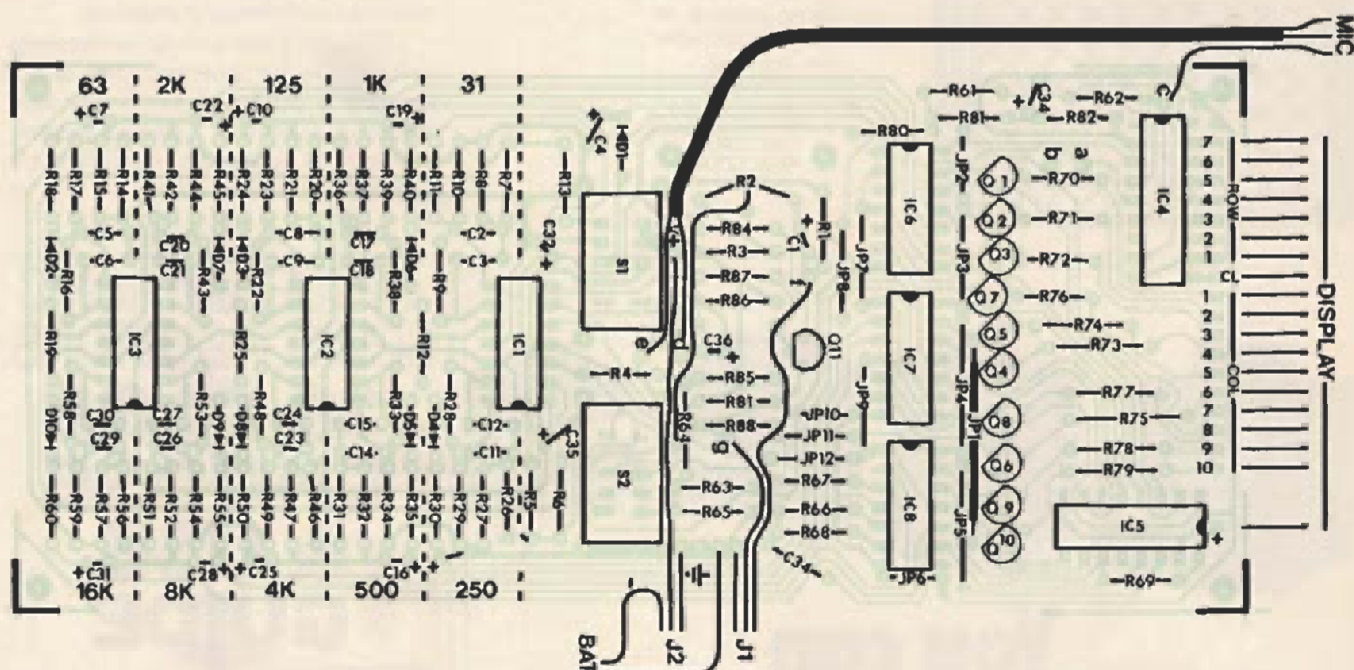
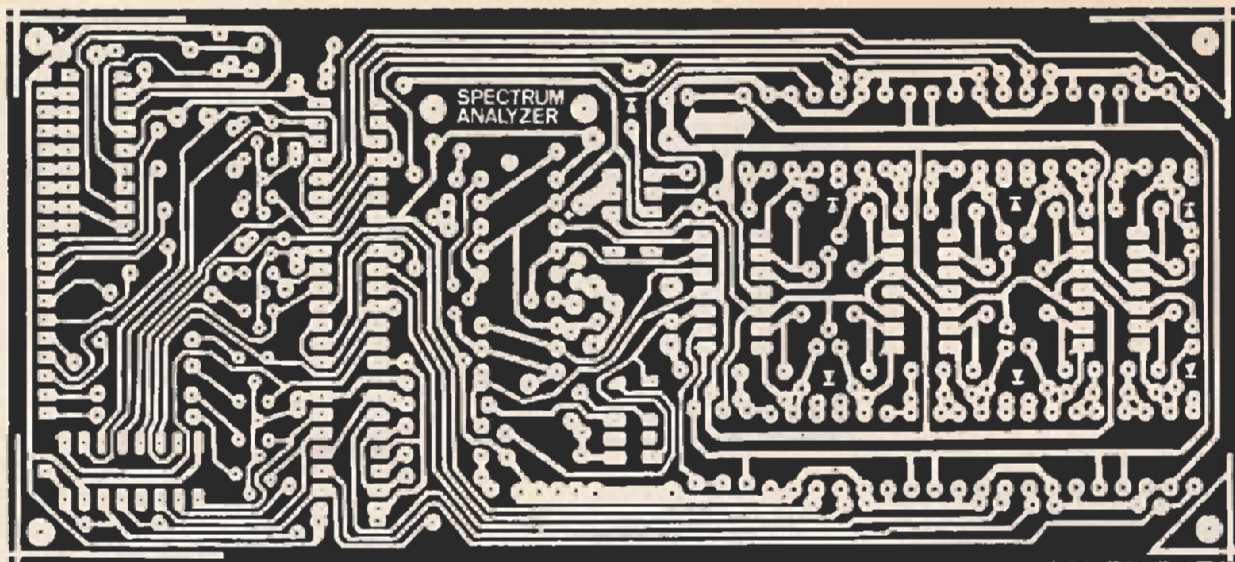

Fig. 6. Actual-size etching and drilling guide (above) and component layout for the main board of the analyzer.

An alternate display is provided by a scope signal as shown in Fig. 2. Connect the sync lead to the sync input of the scope and the signal lead to the scope's vertical input. The scope should be triggered on by the positive edge of the sync signal, and the sweep timebase should be adjusted for exactly 10 divisions between trigger edges. The resulting display will have a linear scale rather than the log scale of the LED display. A typical CRT display is shown in Fig. 5.

Construction. Owing to many components and high packing density, the use of printed circuit boards is essential. Etching and drilling guides and compo-

nent installation layouts for the main and display boards are shown in Figs. 6 and 7, respectively.

Proper orientation of diodes, ICs and polarized capacitors is critical. Also, use 5% tolerance polyester capacitors in the filters to insure accurate center frequency, gain, and Q. As discussed before, proper operation of the HOLD mode depends on the use of capacitors with very low leakage in the bandpass averaging networks. The use of tantalum or low-leakage aluminum electrolytics is urged.

Since the display board is to be mounted very close to the components at the top of the main board, IC sockets cannot be used for IC4 through IC8.

Transistors Q1 through Q10 must be mounted with as little clearance as possible between the bottoms of their cases and the top of the main pc board.

Potentiometer R2 should be mounted on 3/16" spacers with 2-56 small-pattern hardware. The outer terminals of the potentiometer can be connected directly to the board with bare wire. The center lug then connects as indicated in Fig. 6 with a 2" insulated wire.

When assembling the display board, solder the displays directly to the board, noting proper orientation. Solder the clipping indicator LED so that it is flush with the top of the displays.

Once the two board assemblies are

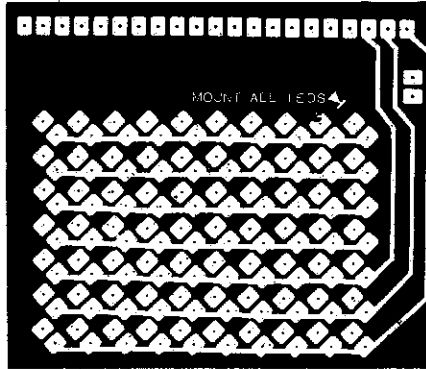
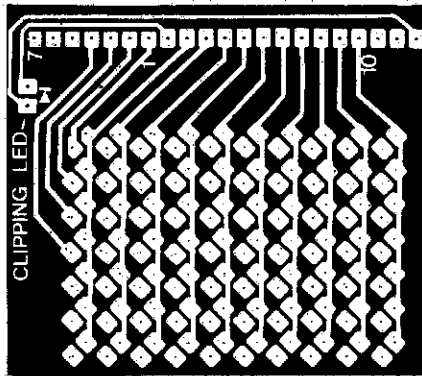

Fig.7. Actual-size foil patterns for the double-sided display board. Pattern at left is for solder side. Above is side on which components are mounted.

wired, they must be interconnected. To do this, insert 1/2" long bare wires through the holes along the top of the display board and solder. Carefully align the wires with the matching holes in the main board. Solder the 19 interconnects allowing 1/4" space between the two boards.

When the project is completely assembled, turn on the power and aim the microphone at a music source. Adjust the level control until a display is obtained. An immediate correlation should be apparent between the sounds you hear or produce and the visual display.

If an audio oscillator is available, connect it through J1 to the analyzer. Every performance aspect can now be checked by setting the oscillator frequency to the various filter center frequencies and changing amplitude.

LEDs of any size or color can be wired according to the schematic. This allows creating a display of nearly any size, shape or color to fit individual requirements. This option may be particularly applicable in rack-mounting. ◇

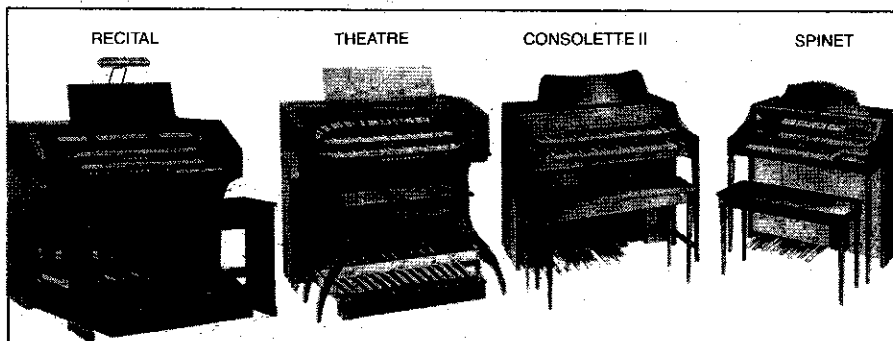

You can assemble any of these Schober Organs

—and save 50% off store prices.

This coupon will bring you the fascinating Schober color catalog which describes the organs and shows you how easy it is to assemble them from Schober's complete kits. Include \$1 if you want a 12-inch demo record.

The *Schober* Organ Corp., Dept. PE-85
43 West 61st Street, New York, N.Y. 10023

- Please send me the Schober Organ Kit Catalog.
- Enclosed is my \$1 for the 12-inch demo record.

Name _____
Address _____
City _____ State _____ Zip _____

CIRCLE NO. 54 ON FREE INFORMATION CARD

OPTOELECTRONIC SEMICONDUCTORS:

28-PAGE CHOOSE & USE GUIDE

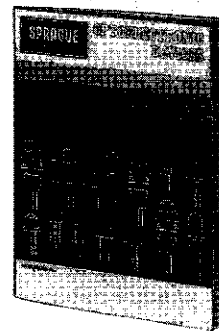

- Describes highly diverse line of optoelectronic devices.
 - Gives data on 77 different visible light-emitting diodes, alpha-numeric light-emitting diode displays, infrared emitters, photo transistors, opto-isolators . . . plus mounting hardware.
 - Includes electrical & mechanical specifications plus characteristic curves.
 - Provides handy cross-reference (other makes to Sprague Products).
- Write for your copy of Guide C-710 to Sprague Products Co., 395 Marshall St., North Adams, Mass. 01247.
- SPRAGUE**
THE MARK OF RELIABILITY
- a subsidiary of **GK Technologies**
- CIRCLE NO. 59 ON FREE INFORMATION CARD