

AUDIO POWER METER

An accurate way to determine what's watt in your hi-fi system, with our true reading power meter

POWER IS PROBABLY the least understood and most misrepresented quantity in the electric measurement system. This is especially so in the area of audio amplifier and speaker specifications when terms like peak, peak to peak, music and RMS are related to power.

Power is simply the rate at which energy is being used. It is expressed in watts and the value may vary from femtowatts (10^{-12} W), as in the input power of a FET, to thousands of megawatts in the power generation field. The term thousand megawatts is generally used in preference to the more correct term, gigawatts.

Power can be calculated simply by multiplying voltage and current:

$$P = EI$$

In a DC circuit where both voltage

and current remain constant no problem arises. However in an AC or a DC circuit where the voltage is not constant with time, this formula only holds for instantaneous power as the power varies with time. Power as we usually use the term is the time average of this. If the load is resistive, i.e. contains no inductance or capacitance, and we can measure the RMS value of the voltage, we can still use this simple formula. However measuring the RMS voltage is not easy as most voltmeters measure the peak or average rectified voltage with a suitable scaling factor built in to give a correct result when measuring a sine wave signal.

Reactive Reaction

If the load is reactive the current and voltage will no longer be in phase,

i.e. the peaks do not occur at the same point in time. The difference can be expressed either by the phase angle in degrees or by the cosine of this angle (known as the power factor). The current waveform can either be ahead of the voltage (leading) or behind it (lagging). Capacitive circuits give rise to a leading power factor while inductive circuits lag.

If working with a sine wave, and if the power factor is known, the formula for power can be expressed as:

$$P = EI \cos \phi$$

where ϕ is the phase angle. In a DC circuit $\cos \phi$ is unity so the formula holds for this case as well. An example is a 40 W fluorescent light which takes 430 mA from the 240 V mains. At first sight, this implies a ►



power consumption of over 100 W, until it is realised that its power factor is about 0.45 lagging. The formula above, using $\cos \phi = 0.45$, thus gives a power consumption of only 46.4 W. (The additional 6 odd watts is dissipated in the ballast.) The product of voltage and current is known as the VA rating and is used when calculating the currents in a circuit. If a capacitor is connected across a sine wave AC circuit the current taken can be calculated by dividing the voltage by the reactance of the capacitor. While this circuit draws current, it has a power factor of very near zero (90° phase lead) and therefore takes no power! By adding the correct amount of capacitance to an inductive circuit (i.e. the fluorescent light) the power factor can be altered, reducing the current drawn (but not the power).

Confused yet?

Ample Reason

Getting back to audio amplifiers and their ratings, the problem lies in the complex nature of the music waveform and how to specify the amplifier's rating. As the waveform is far from a constant sine wave with the peak power being anything up to 20 times the average, numerous methods such as peak power, peak to peak power, music power, etc. evolved. However, for a long time there was no set standard, and one amplifier advertised with a 50 W (music) rating was in fact a 5 W stereo amplifier. The situation got so out of hand that the US Government brought down legislation on how amplifiers were to be tested. This is with a continuous sine wave signal with level set so that the distortion is at a specified level and power calculated from the RMS output voltage: hence the term RMS power. Note however that the term RMS refers to the method of measurement, i.e. the use of RMS voltage, and it is not the RMS value of the power waveform. It is, in fact, the average of the power waveform.

Speakers are just as confusing. They are normally specified not in terms of the power they can dissipate, but the maximum power of amplifier they are suitable for. This is due to the fact that music is never (well, rarely) a continuous sine wave and the average power in the speaker may be only 10% of the RMS rating of the amplifier, even with the amplifier clipping.

To measure the power actually being delivered to the speaker under music conditions, a wattmeter must be used.

Design Features

To multiply current and voltage together we had the choice of analogue or digital techniques. Unfortunately while digital is the 'in' thing, offering versatility and accuracy, it is not fast enough to calculate the instantaneous power on high frequencies. We therefore chose the analogue method.

Looking around the ICs, the only ones with reasonable price and availability were the MC1494, 1495 and 1496. The 1496 (or 796) is the cheapest and most readily available, but has the disadvantage of not being able to multiply DC signals or AC signals with a DC offset. The 1494 and 1495 are about the same price, and of the two, the 1494 was more linear and easier to use.

We chose not to use any input buffer on the voltage input but had to pay the penalty of having a lower input impedance than normal with voltmeters.

Using the Power Meter

To use the meter we must measure both voltage and current. There must be a common point for these measurements. The current

connection can be in either of two ways as shown in the drawings below. One measures the power out of the supply and the second the power into the load. The difference? The current shunt in the wattmeter drops one volt when working at the full range value and this may or may not affect the reading. At 10 A this accounts for 10 W which, if the power being measured is only 100 W, is a 10% error — although if the measured power is 2400 W the error is only 0.4%.

The range of the meter is the product of the individual ranges, i.e. on 30V and 1 A the fsd is 30 W, while 30 V and 3 A gives 100 W FSD. To help give a reading reasonably high on the scale, the voltage range can be overvolted by a factor of 2. Due to power dissipation problems this should not be attempted on the current ranges. The peak voltage or current can be as high as three times the range value.

Construction

We mounted all the components associated with the meter and the switches on a single pc board and if the same or similar case is to be used this is recommended.

Except for the meter and the switches the components are mounted on the 'normal' side of the pc board. These should be mounted ►

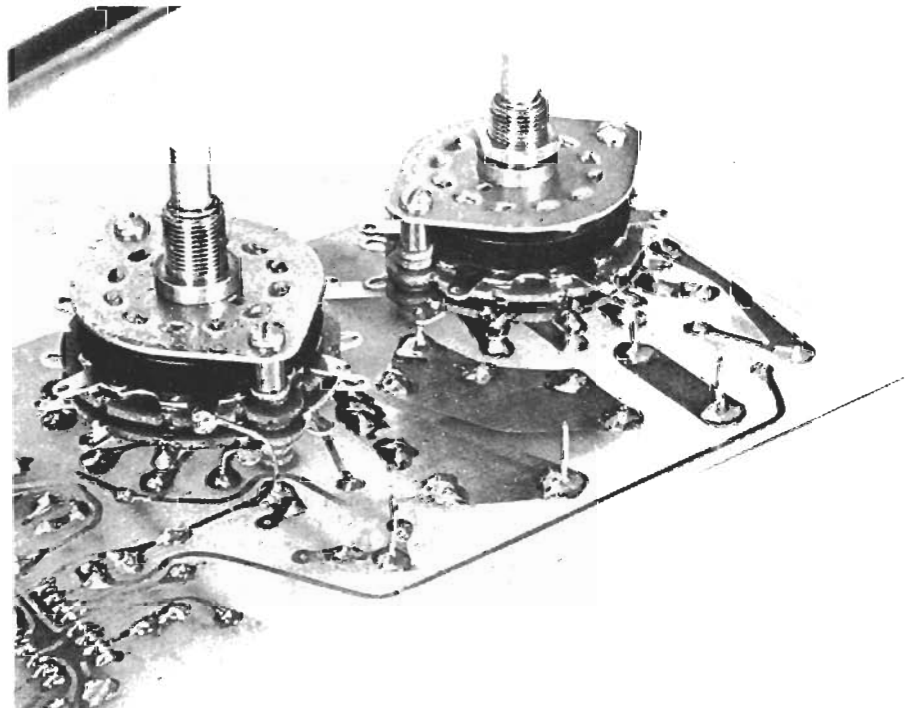

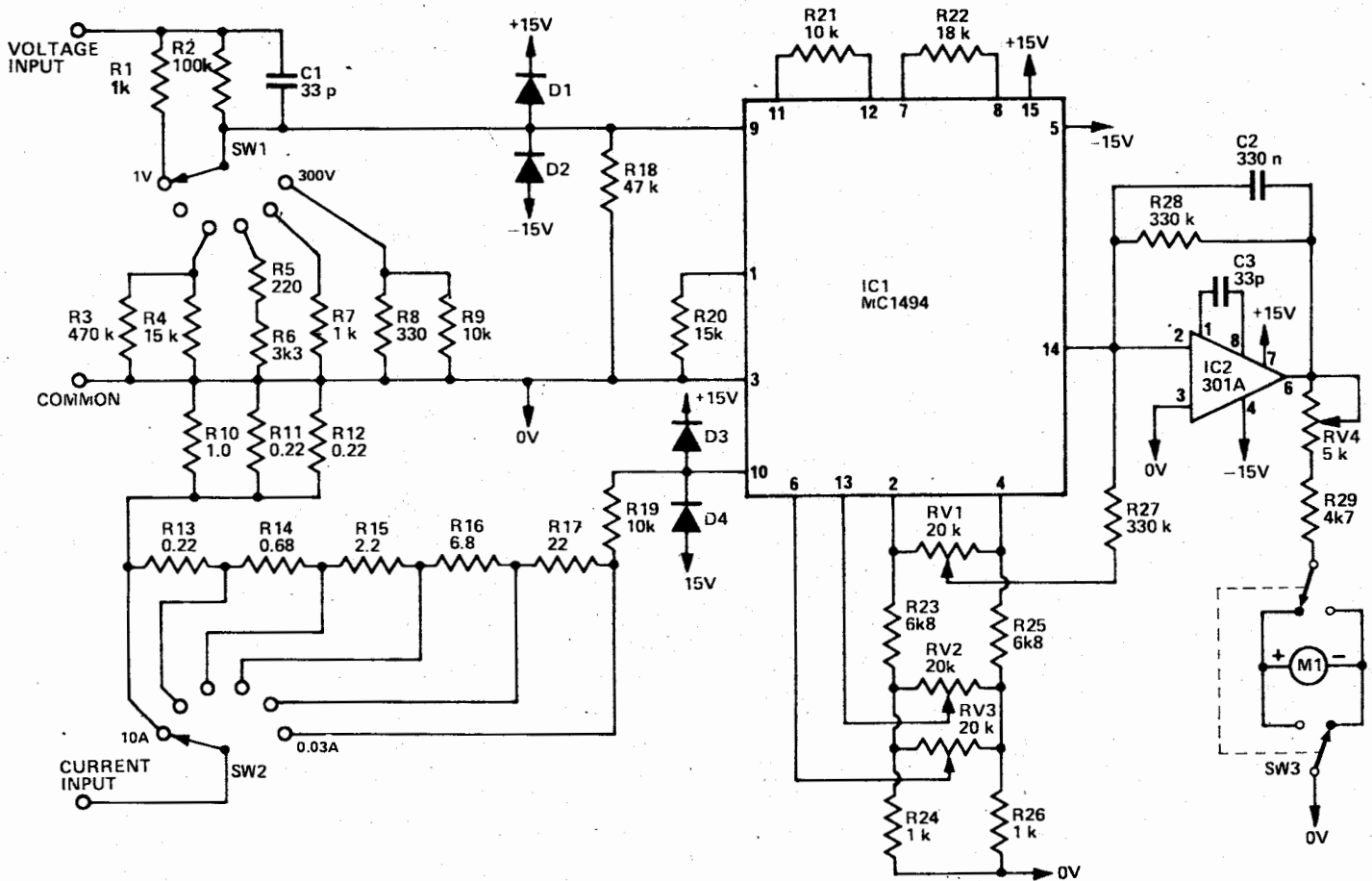

Fig. 1. The circuit diagram of the audio power meter.

HOW IT WORKS

Power is the product of current and voltage. This holds irrespective of the nature of the load, provided you are talking about instantaneous power. By multiplying current and voltage together and then taking the average of these instantaneous values we find the true power. Again this works irrespective of the load.

In this circuit the multiplying is done by IC1 (MC1494), the output of which is a current proportional to the product of the inputs. For more detailed notes on this IC, see the separate section. The current output of this IC is converted to a voltage by IC2 with C2 providing the averaging. The meter is then simply wired across the output of this IC with a meter reversing switch provided. This reversing switch is needed not to measure negative power, but to correct for reversed readings due to differing external connections.

The power supply is a full wave bridge with a centre tap giving about $\pm 20V$ DC which is then regulated to the $\pm 15V$ required by IC1.

Adjustments for zeroing the voltage and current inputs are provided by RV2 and RV3 while RV1 compensates for offsets in the output. These are supplied by a stable $\pm 4V$ reference in IC1. Range switching is done by SW1 and SW2. Protection against overvoluting the IC is provided by D1, D4.

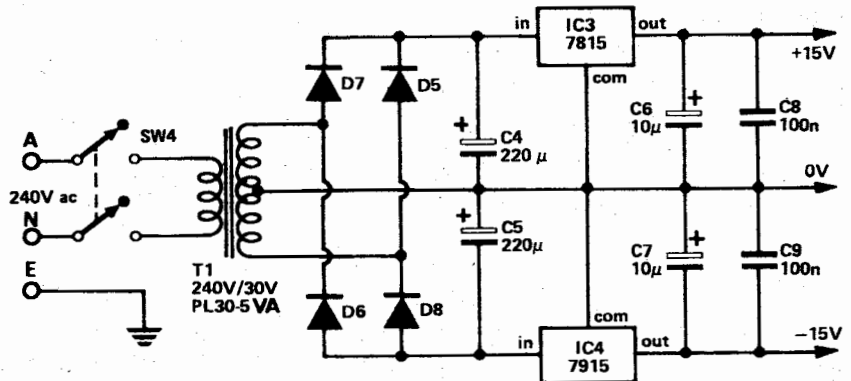
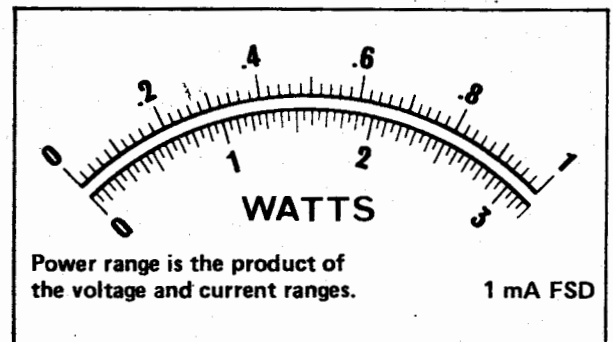

Fig. 2. Power Supply Circuit.

Right: meter scale designed for a 1mA FSD meter. These scales may need to be altered for differing meter units.



PARTS LIST

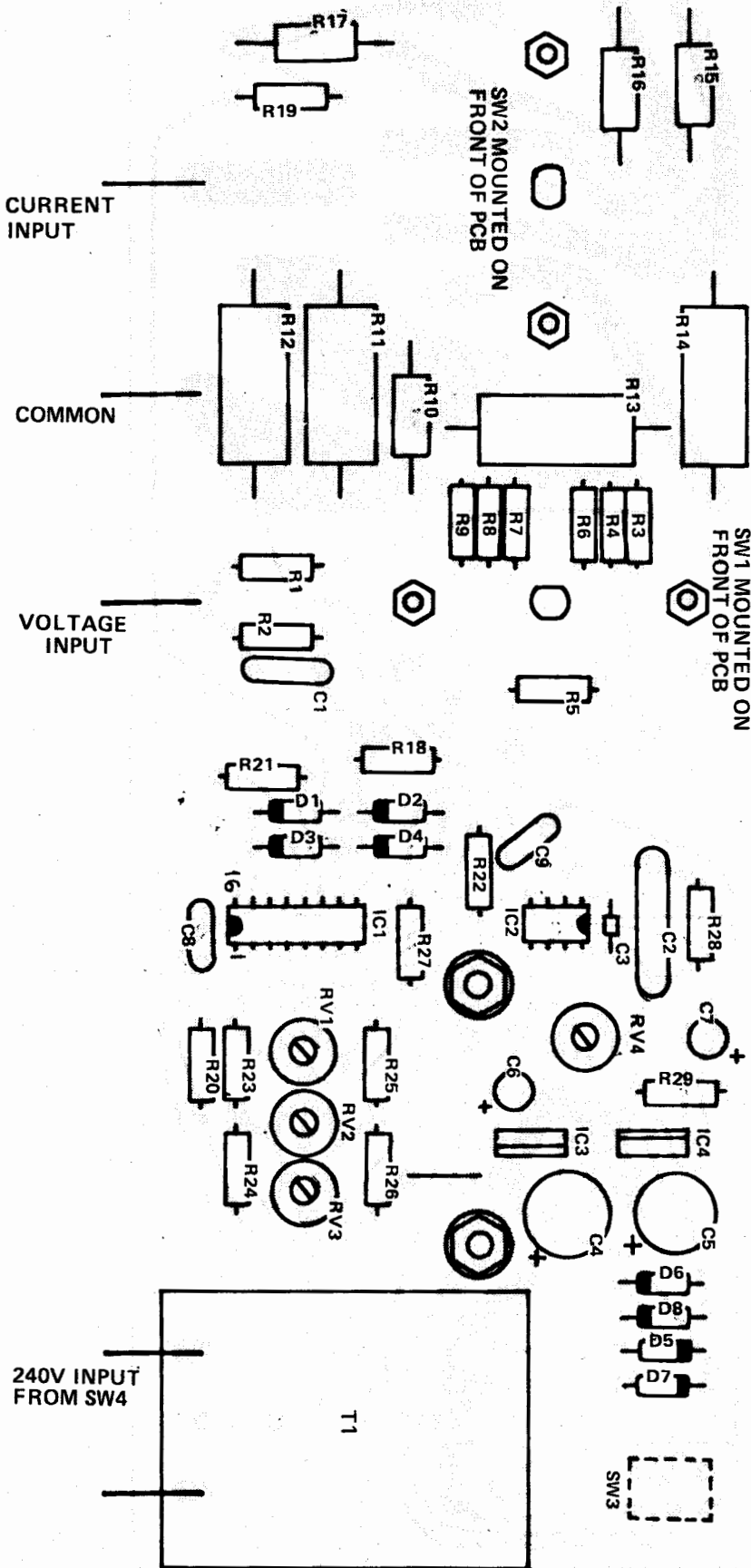

Fig. 3. Overlay for the Power Meter.

Resistors all 5% 1/2W
unless stated

R1, 7, 24, 26	1k
R2	100k
R3	470k
R4, 20	15k
R5	220R
R6	3k3
R8	330R
R9, 19, 21	10k
R10	1R 1W
R11-13 *	OR22 5W
R14	OR68 5W
R15	2R2 1W
R16	6R8 1W
R17	22R
R18	47k
R22	18k
R23, 25	6k8
R27, 28	330k
R29	4k7

POTENTIOMETERS

RV1-3	20k trimmer
RV4	5k trimmer

CAPACITORS

C1	33p 500V ceramic
C2	330n polyester
C3	33p ceramic
C4, 5	220u 35V electrolytic
C6, 7	10u 25V electrolytic
C8, 9	100n polyester

SEMICONDUCTORS

IC1	MC1494
IC2	301A
IC3	7815
IC4	7915
D1-D4	1N914
D5-D8	1N4004

MISCELLANEOUS

PCB
SW1, 2 two pole 6 position 10A rotary Radiospares
SW3, 4 two pole toggle switches
Transformer 15-0-15, 5VA
Meter 1mA FSD
Three binding posts
Instrument case 255 x 100 x 205mm
Power cord and clamp
Two knobs
Front panel

BUYLINES

Most of the parts for this project are readily available. Two things which may cause trouble are the switch assemblies and the quadrant multiplier itself.

The switch is an RS unit and as such can be obtained from any of their stockists. As for the IC, Tamtronik — who advertise on page 32 of this issue — can supply this and by the time you read this they will be able to sell you all the rest as well!

first with the only critical part of the assembly in the area of the range switches. Here the high powered resistors should be spaced at least 5mm from the PCB as they run hot at maximum current. Also the leads of all the resistors in this area should be cut off close to the pc board after soldering. This is to give adequate clearance to the rotary switches. We used two self tapping screws into the plastic of the transformer case to help fix it onto the board. We have made ▶

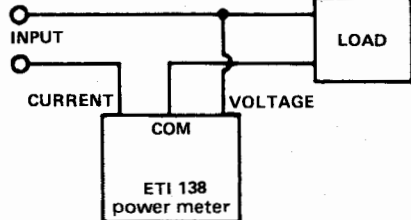

Fig. 4. This connection measures the power into the load.

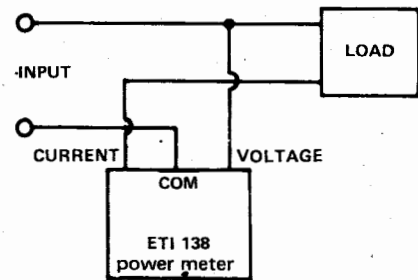

Fig. 5. This connection measures the power out of the supply.

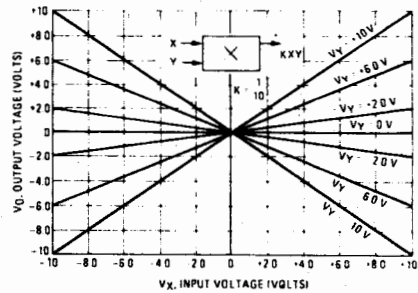

Fig. 6. Transfer characteristics of the IC.

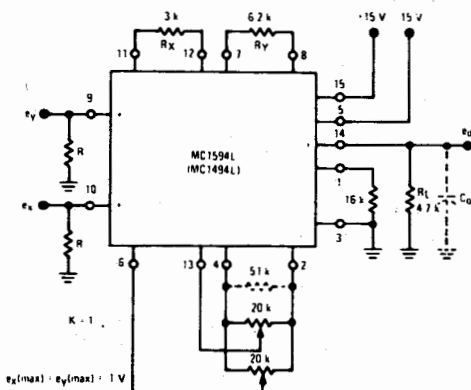

Fig. 7. Typical connections for a wide band multiplier or balanced modulator.

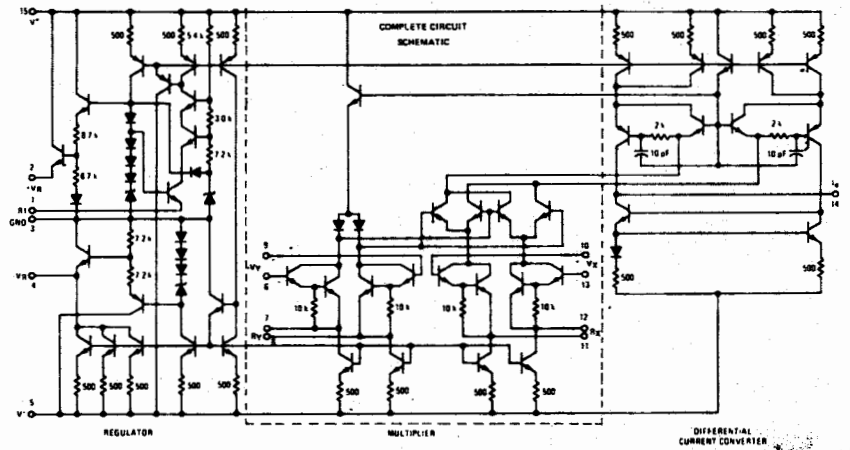

Fig. 8. The internal circuit diagram of the IC.

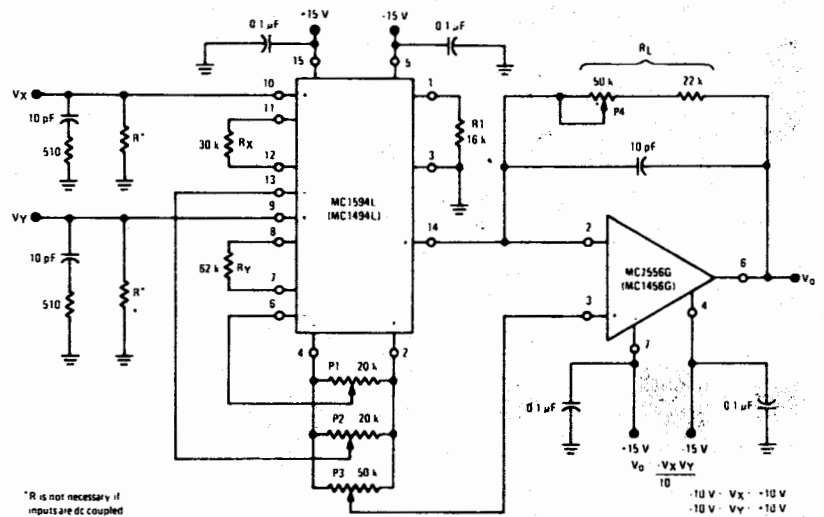

Fig. 9. Typical connection of a low frequency multiplier. For a squaring circuit simply parallel the two inputs. In this case pin 6 can be connected to 0V and P1 deleted.

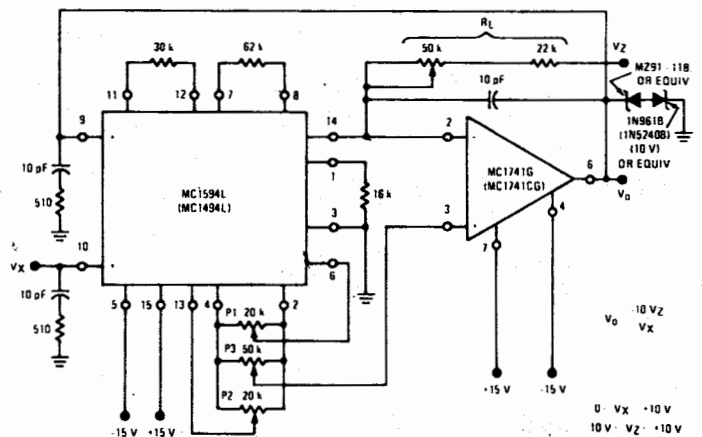
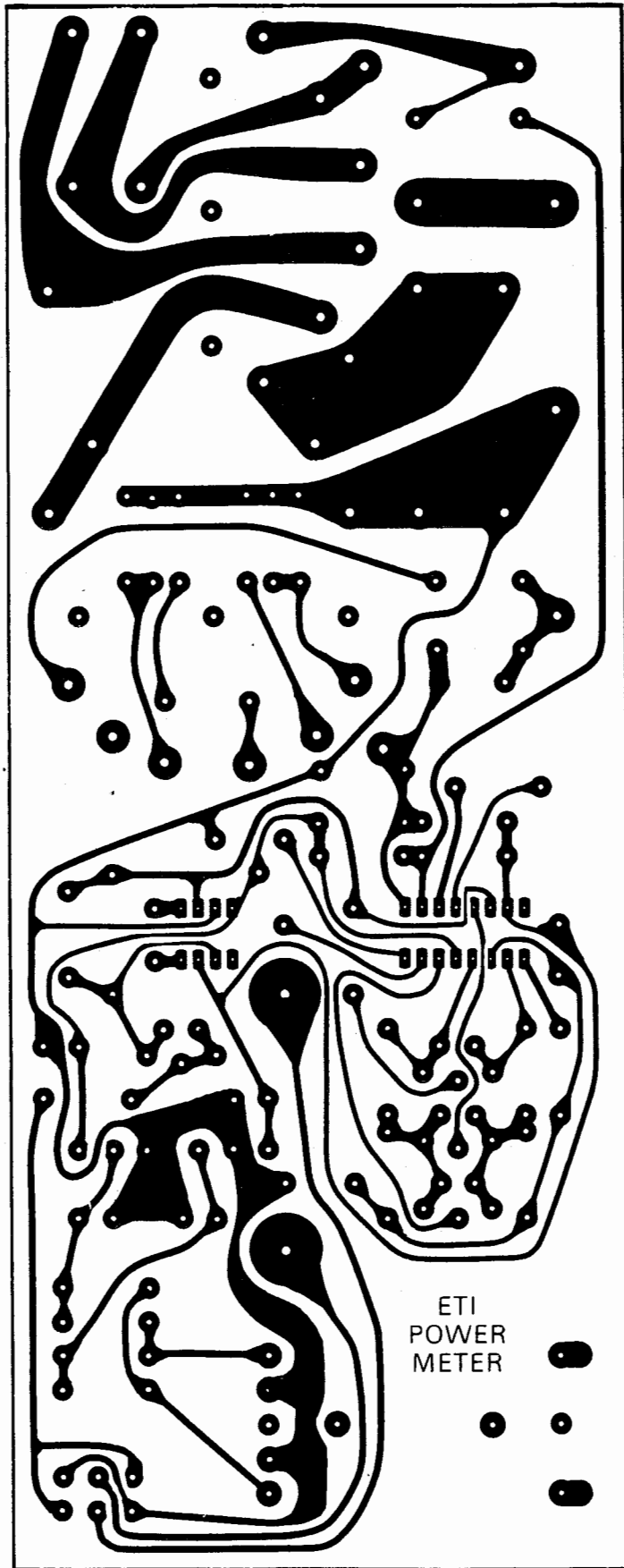

Fig. 10. Typical connection of a divide circuit. For the square root joins pin 9 and 10. Like the squaring circuits pin-6 can be connected to 0V and P1 deleted.

Full size foil pattern for the power meter.



allowance for either the cermet (VTP) or the normal carbon trim potentiometer.

Calibration

Four adjustments are required, which are performed as follows:

Select the 1 V and 0.03 A ranges and switch on. If the meter reads in reverse, toggle SW3. Don't worry about the reading unless it is off scale. If it is, adjust RV1 to bring it back towards zero. Now apply a voltage of about 1V DC to the voltage input and note the meter deflection. Adjust RV2* until there is no deflection when this voltage is applied. Now apply the voltage to the current input (it will take about 30 mA) and adjust RV3 until there is no deflection. Recheck the voltage input and readjust if necessary.

Now with no voltage applied adjust RV1 to give zero output. Apply exactly 1 V to both current and voltage inputs and adjust RV4 to make the meter read FSD.

This is all the calibration that should be necessary.

About the 1494

The 1494 is a variable transconductance multiplier with a bidirectional current source output. What this means is that it looks at the voltage on the two points and gives an output current potential to the product of the two. Typical applications include: multiply, divide, square, square root, phase detection, frequency doubling, balanced modulation/demodulation and electronic gain control. An internal circuit diagram is given for those interested.

Values and Limitations

- 1 For best temperature coefficient R1 (pin 1 to 0V) should be 16k (we used 15k as it is easier to obtain). This sets the value of all the current sources inside the IC ($I1 = 8/R1$)
- 2 The value of Rx (pin 11 to pin 12) should be $\geq 3x$ peak input voltage(X) expressed in k ohms.
- 3 The value of Ry (pin 7 to pin 8) should be $\geq 6x$ peak input voltage(Y) expressed in k ohms.
- 4 Choose the scaling factory required ie $V_{out} = K \cdot V_x \cdot V_y$.
- 5 Load resistance (pin 14 to 0V) can be calculated by $RL = (K \cdot Rx \cdot Ry) / I1 / 2$
- 6 If RL is connected between pin 14 and 0V without an inverting amp. the frequency response is limited by the output capacitance of 10pF.
- 7 For best temperature coefficient the load between pins 2 and 4 should be 8.6k.

ETI