

Add simple disable function to a panoramic-potentiometer circuit

Lawrence Mayes, Malvern, United Kingdom

In audio-mixing applications, one frequently required function involves mixing a monaural or single-channel source into a stereo-sound field. Audio engineers refer to a panoramic-potentiometer circuit as a circuit that generates left and right signals of correct amplitudes from a monaural signal and places the signal's image anywhere in a stereo-sound field. For the image's loudness to appear independent of its final position, the derived left and right signals must add to produce a constant-power signal rather than a constant-voltage signal.

The widely used circuit in **Figure 1** performs this function by dividing the monaural signal between the two stereo channels and varying each channel's gain between zero and M such that at R_7 's centered position, each channel's gain is $0.707M$. If you calculate component values to achieve these conditions, then the circuit presents the remarkable property that, for all positions of R_7 's wiper, the sum of the powers in the left and right channels is constant to within 0.19 dB.

You can use a DPDT switch, S_1 , to bypass the circuit and thus remove it from the audio chain (**Figure 2**). As an alternative, you can add two resis-

tors and use an SPST switch to disable or enable the circuit. The circuit in **Figure 3** presents the same gain characteristics as in **Figure 1**. Closing switch S_1 enables the panoramic-potentiometer function, and open-

ing the switch produces a fixed central-sound image. Additionally, from a practical viewpoint, the circuit of **Figure 3** simplifies wiring and introduces no significant switching transient because enabling the panoramic-potentiometer function involves only grounding R_7 's wiper. Even when you use preferred-value components and disregard component tolerances, the circuit introduces a maximum gain error of only 0.21 dB.**EDN**

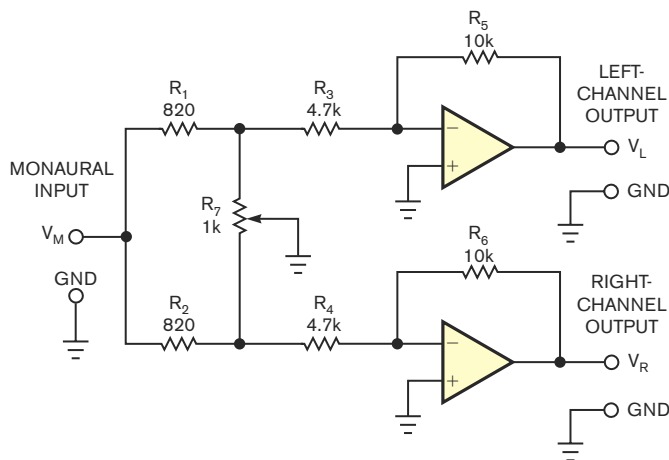

Figure 1 In this basic panoramic-potentiometer circuit, the position of R_7 's wiper controls the position of a monaural image in a stereo audio signal.

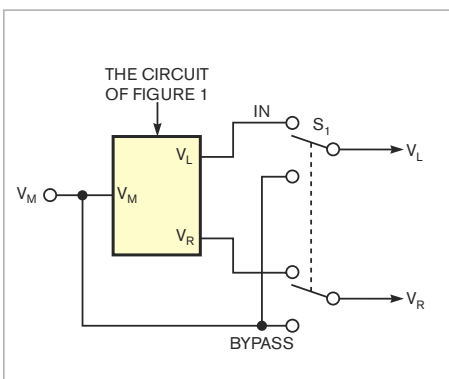
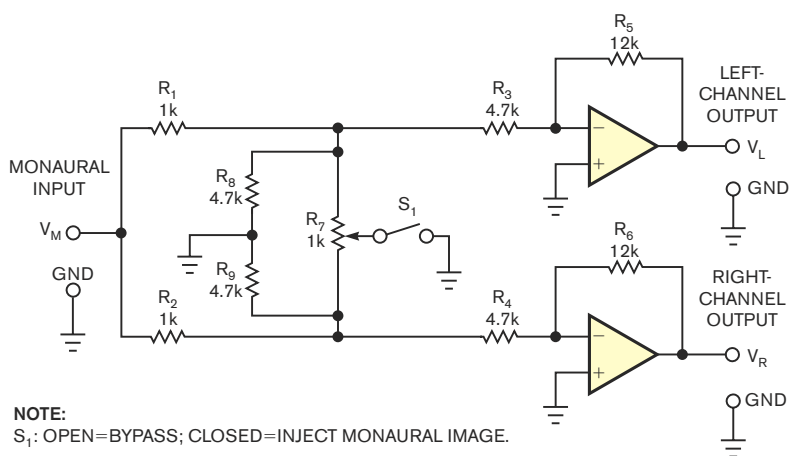

Figure 2 A DPDT switch removes the panoramic potentiometer but introduces wiring complexity and transients.



NOTE:
 S_1 : OPEN=BYPASS; CLOSED=INJECT MONAURAL IMAGE.

Figure 3 Adding resistors R_7 and R_8 and SPST switch S_1 simplifies wiring and minimizes transients.