

High-Performance Audio Applications of The LM833

National Semiconductor
Application Note 346
Kerry Lacanette



Designers of quality audio equipment have long recognized the value of a low noise gain block with "audiophile performance". The LM833 is such a device: a dual operational amplifier with excellent audio specifications. The LM833 features low input noise voltage (4.5 nV/ $\sqrt{\text{Hz}}$ typical), large gain-bandwidth product (15 MHz), high slew rate (7V/ μSec), low THD (0.002% 20 Hz-20 kHz), and unity gain stability. This Application Note describes some of the ways in which the LM833 can be used to deliver improved audio performance.

I. TWO STAGE RIAA PHONO PREAMPLIFIER

A phono preamplifier's primary task is to provide gain (usually 30 to 40 dB at 1 kHz) and accurate amplitude and phase equalization to the signal from a moving magnet or a moving coil cartridge. (A moving coil device's output voltage is typically around 20 dB lower than that of a moving magnet pick-up, so this signal is usually amplified by a step-up device—either an active circuit or a transformer—before being applied to the input of the phono preamplifier). In addition to the amplification and equalization functions, the phono preamp must not add significant noise or distortion to the signal from the cartridge.

Figure 1 shows the standard RIAA phono preamplifier amplitude response. Numerical values relative to the 1 kHz gain are given in Table I. Note that the gain rolls off at a 6 dB/octave rate above 2122 Hz. Most phono preamplifier circuits in commercially available audio products, as well as most published circuits, are based on the topology shown in Figure 2(a). The network consisting of R_1 , R_2 , C_1 , and C_2 is not unique, and can be replaced by any of several other networks that give equivalent results. R_0 is generally well under 1k to keep its contribution to the input noise voltage below that of the cartridge itself. The 47k resistor shunting the input provides damping for moving-magnet phono cartridges. The input is also shunted by a capacitance equal to the sum of the input cable capacitance and C_p . This capacitance resonates with the inductance of the moving magnet cartridge around 15 kHz to 20 kHz to determine the frequency response of the transducer, so when a moving magnet pickup is used, C_p should be carefully chosen so that the total capacitance is equal to the recommended load capacitance for that particular cartridge.

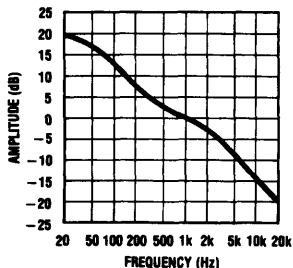

TL/H/5520-1

FIGURE 1. Standard RIAA phonograph preamplifier frequency response curve. Gain continues to roll off at a 6 dB/octave rate above 20 kHz.

Table I. RIAA standard response referred to gain at 1 kHz.

FREQUENCY (Hz)	AMPLITUDE (dB)	FREQUENCY (Hz)	AMPLITUDE (dB)
20	+19.3	800	+0.7
30	+18.6	1000	0.0
40	+17.8	1500	-1.4
50	+17.0	2000	-2.6
60	+16.1	3000	-4.8
80	+14.5	4000	-6.6
100	+13.1	5000	-8.2
150	+10.3	6000	-9.6
200	+8.2	8000	-11.9
300	+5.5	10000	-13.7
400	+3.8	15000	-17.2
500	+2.6	20000	-19.6

The circuit of *Figure 2(a)* has a disadvantage: it cannot accurately follow the curve in *Figure 1*, no matter what values are chosen for the feedback resistors and capacitors. This is because the non-inverting amplifier cannot have a gain of less than unity, which means that the high frequency gain cannot roll off continuously above the 2122 Hz breakpoint as it is supposed to. Instead, a new breakpoint is introduced at the unity gain frequency.

In addition to the amplitude response errors (which can be made small through careful design), the lack of a continued rolloff can cause distortion in later stages of the audio system by allowing high frequency signals from the pickup cartridge to pass through the phono equalizer without sufficient attenuation. This is generally not a problem with moving magnet cartridges, since they are usually severely band-limited above 20 kHz due to the electrical resonance of cartridge inductance and preamp input capacitance. Moving coil cartridges, however, have very low inductance, and can produce significant output at frequencies as high as 150 kHz. If a subsequent preamplifier stage or power amplifier suffers from distortion caused by slew-rate limitations, these ultrasonic signals can cause distortion of the audio signal even though the signals actually causing the distortion are inaudible.

Preamplifiers using the topology of *Figure 2(a)* can suffer from distortion due to input stage nonlinearities that are not corrected by the feedback loop. The fact that practical amplifiers have non-infinite common mode rejection ratios means that the amplifier will have a term in its gain function that is dependent on the input voltage level. Since most good operational amplifiers have very high common mode rejection ratios, this form of distortion is usually quite difficult to find in opamp-based designs, but it is very common in discrete amplifiers using two or three transistors since these circuits generally have poor common mode performance. Another source of input stage distortion is input impedance nonlinearity. Since the input impedance of an amplifier can vary depending on the input voltage, and the signal at the amplifier input will be more strongly affected by input impedance if the source impedance is high, distortion will generally increase as the source impedance increases. Again, this problem will typically be significant only when the amplifier is a simple discrete design, and is not generally troublesome with good op amp designs.

The disadvantages of the circuit configuration of *Figure 2(a)* have led some designers to consider the use of RIAA preamplifiers based on the inverting topology shown in *Figure 2(b)*. This circuit can accurately follow the standard RIAA

response curve since the absolute value of its gain can be less than unity. The reduced level of ultrasonic information at its output will sometimes result in lower perceived distortion (depending on the design of the other components in the audio system). Since there is no voltage swing at the preamplifier input, distortion will be lower in cases where the gain block has poor common-mode performance. (The common-mode distortion of the LM833 is low enough that it exhibits essentially the same THD figures whether it is used in the inverting or the non-inverting mode.)

The primary handicap of the inverting configuration is its noise performance. The 47k resistor in series with the source adds at least 4 μV of noise (20 Hz to 20 kHz) to the preamplifier's input. In addition to 4 μV of thermal noise from the 47k resistor, the high impedance in series with the preamp input will generally result in a noise increase due to the preamplifier's input noise current, especially when the series impedance is made even larger by a moving magnet cartridge at resonance. In contrast, the 47k damping resistor in *Figure 2(a)* is in parallel with the source, and is a significant noise contributor only when the source impedance is high. This will occur near resonance, when the source is a moving magnet cartridge. Since the step-up devices used with moving coil cartridges present a low, primarily resistive source impedance to the preamplifier input, the effects of cartridge resonance and input noise current are virtually eliminated for moving coil sources. Therefore, the circuit of *Figure 2(a)* has a noise advantage of about 16 dB with a moving coil source, and from about 13 dB to about 18 dB (depending on the source impedance and on the input noise current of the amplifier) with a moving magnet source. Using the component values shown, the circuit in *Figure 2(a)* follows the RIAA characteristic with an accuracy of better than 0.5 dB (20–20 kHz) and has an input-referred noise voltage equal to 0.33 μV over the Audio frequency range.

Even better performance can be obtained by using the two-amplifier approach of *Figure 3*. The first operational amplifier takes care of the 50 Hz and 500 Hz breakpoints, while the 2122 Hz rolloff is accomplished by the passive network R_3 , R_6 , and C_3 . The second amplifier supplies additional gain—10 dB in this example. Using two amplifiers results in accurate conformance to the RIAA curve without reverting to the noisy inverting topology, as well as lower distortion due to the fact that each amplifier is operating at a lower gain than would be the case in a single-amplifier design. Also, the amplifiers are not required to drive capacitive feedback networks with the full preamplifier output voltages, fur-

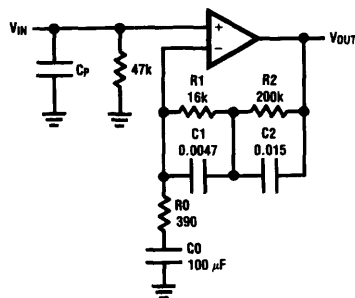

(a)

TL/H/5520-2

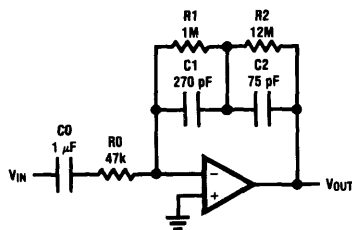

(b)

TL/H/5520-16

FIGURE 2. Two typical operational amplifier-based phono preamplifier circuits. (a) Non-inverting. (b) Inverting.

ther reducing distortion compared to the single-amplifier designs.

The design equations for the preamplifier are:

1) $R_1 = 8.058 R_0 A_1$, where A_1 is the 1 kHz voltage gain of the first amplifier.

2) $C_1 = \frac{3.18 \times 10^{-3}}{R_1}$

3) $R_2 = \frac{R_1}{9} - R_0$

4) $C_3 = 7.5 \times 10^{-5} \frac{(R_3 + R_6)}{R_3 R_6} = \frac{7.5 \times 10^{-5}}{R_P}$

5) $C_4 = \frac{1}{2\pi f_L (R_3 + R_6)}$

where f_L is the low-frequency -3 dB corner of the second stage. For standard RIAA preamplifiers, f_L should be kept well below the audible frequency range. If the preamplifier is to follow the IEC recommendation (IEC Publication 98, Amendment #4), f_L should equal 20.2 Hz.

6) $A_{V2} = 1 + \frac{R_5}{R_4}$

where A_{V2} is the voltage gain of the second amplifier.

7) $C_0 \approx \frac{1}{2\pi f_0 R_0}$

where f_0 is the low-frequency -3 dB corner of the first amplifier. This should be kept well below the audible frequency range.

A design procedure is shown below with an illustrative example using 1% tolerance E96 components for close conformance to the ideal RIAA curve. Since 1% tolerance capacitors are often difficult to find except in 5% or 10% standard values, the design procedure calls for re-calculation of a few component values so that standard capacitor values can be used.

RIAA PHONO PREAMPLIFIER DESIGN PROCEDURE

- 1) Choose R_0 . R_0 should be small for minimum noise contribution, but not so small that the feedback network excessively loads the amplifier.

Example: Choose $R_0 = 500$.

- 2) Choose 1 kHz gain, A_{V1} of first amplifier. This will typically be around 20 dB to 30 dB.

Example: Choose $A_{V1} = 26 \text{ dB} = 20$.

- 3) Calculate $R_1 = 8.058 R_0 A_{V1}$

Example: $R_1 = 8.058 \times 500 \times 20 = 80.58\text{k}$.

4) Calculate $C_1 = \frac{3.18 \times 10^{-3}}{R_1}$

Example: $C_1 = \frac{3.18 \times 10^{-3}}{8.058 \times 10^4} = 0.03946 \mu\text{F}$

- 5) If C_1 is not a convenient value, choose the nearest convenient value and calculate a new R_1 from

$$R_1 = \frac{3.18 \times 10^{-3}}{C_1}$$

Example: New $C_1 = 0.039 \mu\text{F}$.

$$\text{New } R_1 = \frac{3.18 \times 10^{-3}}{3.9 \times 10^{-8}} = 81.54\text{k}$$

Use $R_1 = 80.6\text{k}$.

- 6) Calculate a new value for R_0 from $R_0 = \frac{R_1}{8.058 A_{V1}}$

Example: New $R_0 = \frac{80.6 \times 10^4}{8.058 \times 20} = 498.8$.

Use $R_0 = 499$.

- 7) Calculate $R_2 = \frac{R_1}{9} - R_0$

Example: $R_2 = \frac{80.6 \times 10^4}{9} - 499 = 8456.56$

Use 8.45k.

- 8) Choose a convenient value for C_3 in the range from 0.01 μF to 0.05 μF .

Example: $C_3 = 0.033 \mu\text{F}$.

- 9) Calculate $R_P = \frac{7.5 \times 10^{-5}}{C_3}$

Example: $R_P = \frac{7.5 \times 10^{-5}}{3.3 \times 10^{-8}} = 2.273\text{k}$.

- 10) Choose a standard value for R_3 that is slightly larger than R_P .

Example: $R_3 = 2.37\text{k}$.

- 11) Calculate R_6 from $1/R_6 = 1/R_P - 1/R_3$

Example: $R_6 = 55.36\text{k}$

Use 54.9k.

- 12) Calculate C_4 for low-frequency rolloff below 1 Hz from design equation (5).

Example: $C_4 = 2 \mu\text{F}$. Use a good quality mylar, polystyrene, or polypropylene.

- 13) Choose gain of second amplifier.

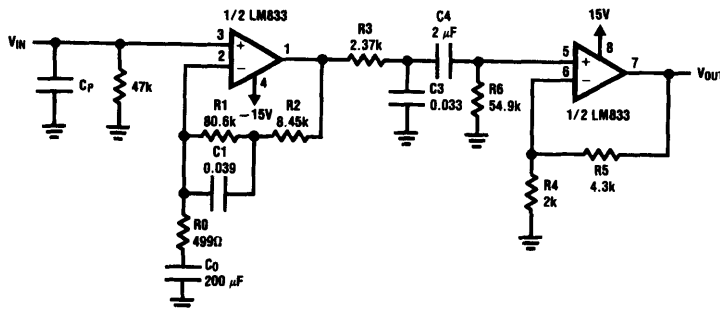

FIGURE 3. Two-amplifier RIAA phono preamplifier with very accurate RIAA response.

Example: The 1 kHz gain up to the input of the second amplifier is about 26 dB for this example. For an overall 1 kHz gain equal to about 36 dB we choose:

$$A_{V2} = 10 \text{ dB} = 3.16.$$

14) Choose value for R_4 .

Example: $R_4 = 2k$.

15) Calculate $R_5 = (A_{V2} - 1) R_4$

Example: $R_5 = 4.32k$.

Use $R_5 = 4.3k$

16) Calculate C_0 for low-frequency rolloff below 1 Hz from design equation (7).

Example: $C_0 = 200 \mu\text{F}$.

The circuit of *Figure 3* has excellent performance: Conformance to the RIAA curve is within 0.1 dB from 20 Hz to 20 kHz, as illustrated in *Figure 4* below for a prototype version of the circuit. THD and noise data are reproduced in *Figure 5* and *Table II*, respectively. If a "perfect" cartridge with 1mV/cm/s sensitivity (higher than average) is used as the input to this preamplifier, the highest recorded groove velocities available on discs (limited by the cutting equipment) will fall below the 1V curve except in the 1 kHz to 10 kHz region, where isolated occurrences of 2V to 3V levels can be generated by one or two of the "superdiscs". (See reference 4). The distortion levels at those frequencies and signal levels are essentially the same as those shown on the 1V curve, so they are not reproduced separately here. It should be noted that most real cartridges are very limited in their ability to track such large velocities, and will not generate preamplifier output levels above 1Vrms even under high groove velocity conditions.

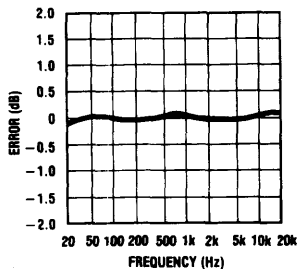

TL/H/5520-4

FIGURE 4. Deviation from ideal RIAA response for circuit of *Figure 3* using 1% resistors. The maximum observed error for the prototype was 0.1 dB.

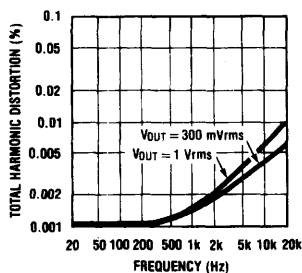

TL/H/5520-5

FIGURE 5. THD of circuit in *Figure 3* as a function of frequency. The lower curve is for an output level of 300mVrms and the upper curve is for an output level of 1Vrms.

Table II. Equivalent input noise and signal-to-noise ratio for RIAA preamplifier circuit of *Figure 3*. Noise levels are referred to gain at 1 kHz.

NOISE WEIGHTING	CCIR/ARM	"A"	FLAT
Noise voltage	0.26 μV	0.23 μV	0.37 μV
S/N referred to 5 mV input at 1 kHz	86 dB	87 dB	82 dB

II. ACTIVE CROSSOVER NETWORK FOR LOUSPEAKERS

A typical multi-driver loudspeaker system will contain two or more transducers that are intended to handle different parts of the audio frequency spectrum. Passive filters are usually used to split the output of a power amplifier into signals that are within the usable frequency range of the individual drivers. Since passive crossover networks must drive loudspeaker elements whose impedances are quite low, the capacitors and inductors in the crossovers must be large in value, meaning that they will very likely be expensive and physically large. If the capacitors are electrolytic types or if the inductors do not have air cores, they can also be significant sources of distortion. Furthermore, many desirable filter characteristics are either impossible to realize with passive circuitry, or require so much attenuation to achieve passively that system efficiency is severely reduced.

An alternative approach is to use low-level filters to divide the frequency spectrum, and to follow each of these with a separate power amplifier for each driver or group of drivers. A two-way (or "bi-amped") system of this type is shown in *Figure 6*. This basic concept can be expanded to any number of frequency bands. For accurate sound reproduction, the sum of the filter outputs should be equal to the crossover input (if the transducers are "ideal"). While this seems to be an obvious requirement, it is very difficult to find a commercial active dividing network that meets it. Consider an active crossover consisting of a pair of 2nd-order Butterworth filters, (one is a low-pass; the other is a high-pass). The transfer functions of the filters are of the form:

$$\frac{V_L(s)}{V_{in}(s)} = \frac{1}{s^2 + \sqrt{2}s + 1}$$

$$\frac{V_H(s)}{V_{in}(s)} = \frac{s^2}{s^2 + \sqrt{2}s + 1}$$

and their sum is:

$$\frac{V_L(s)}{V_{in}(s)} + \frac{V_H(s)}{V_{in}(s)} = \frac{1 + s^2}{s^2 + \sqrt{2}s + 1}$$

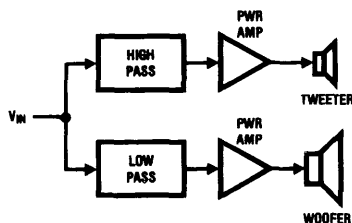

TL/H/5520-6

FIGURE 6. Block diagram of a two-way loudspeaker system using a low level crossover network ahead of the power amplifiers.

The output will therefore never exactly equal the input signal (except in the trivial case of a DC input). Figure 7 shows the response of this crossover to a square wave input, and the amplitude and phase response of the crossover to sinusoidal steady state inputs can be seen in Figure 8. Higher-order filters will yield similarly dissatisfying results when this approach is used.

A significant improvement can be made by the use of a constant voltage crossover like the one shown in Figure 9. The term "constant voltage" means that the outputs of the high-pass and low-pass sections add up to produce an exact replica of the input signal. The rolloff rate is 12 dB/oct-

tave. The input impedance is equal to $R/2$, or 12 k Ω in the circuit of Figure 9. The LM833 is especially well-suited for active filter applications because of its high gain-bandwidth product. The transfer functions of this crossover network are of the form

$$\frac{V_L(s)}{V_{in}(s)} = \frac{a_1s + 1}{a_3s^3 + a_2s^2 + a_1s + 1}$$

and

$$\frac{V_H(s)}{V_{in}(s)} = \frac{a_3s^3 + a_2s^2}{a_3s^3 + a_2s^2 + a_1s + 1}$$

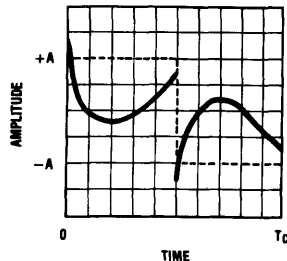

TL/H/5520-7

FIGURE 7. Response of second-order Butterworth crossover network (high-pass and low-pass outputs summed) to a square wave input (dashed line) at the crossover frequency. Period is $T_C = 1/f_C$.

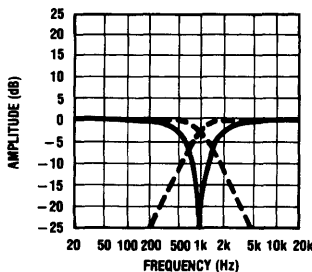

(a)

TL/H/5520-8

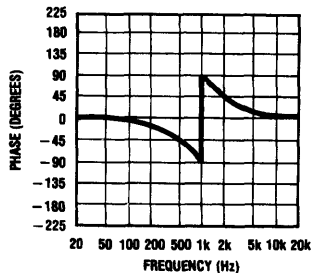

(b)

TL/H/5520-17

FIGURE 8. Magnitude (a) and phase (b) response of a second-order, 1 kHz Butterworth crossover network with the high-pass and low-pass outputs summed. The individual high-pass and low-pass outputs are superimposed (dashed lines).

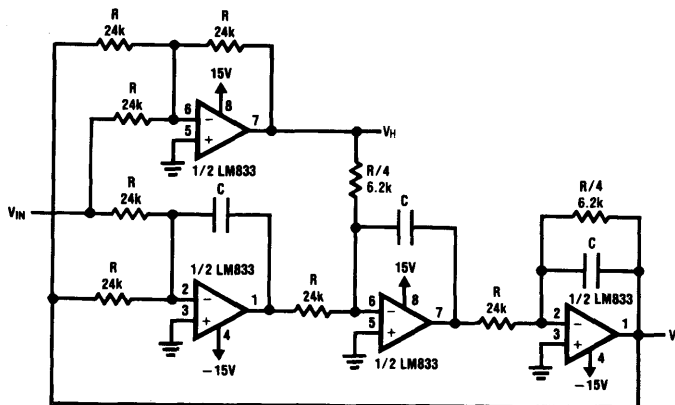

TL/H/5520-9

FIGURE 9. Constant-voltage crossover network with 12 dB/octave slopes.

The crossover frequency is equal to $\frac{1}{2\pi RC}$.

The low-pass and high-pass constant voltage crossover outputs are plotted in *Figure 10*. The square-wave response (not shown) of the summed outputs is simply an inverted square-wave, and the phase shift (also not shown) is essentially 0° to beyond 20 kHz.

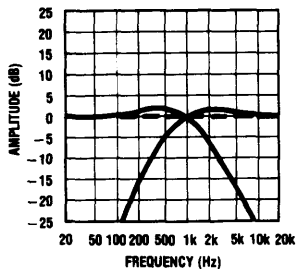

TL/H/5520-10

FIGURE 10. Low-pass and high-pass responses of constant-voltage crossover network in *Figure 9* with crossover frequency of 1 kHz. For the circuit of *Figure 9*, $a_1 = 4$, $a_2 = 4$, and $a_3 = 1$. Note that the summed response (dashed lines) is perfectly flat.

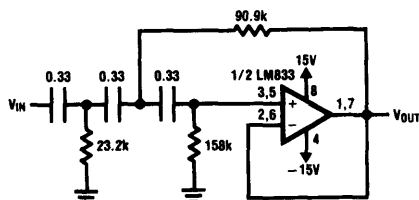

TL/H/5520-11

FIGURE 11. Filter for rejection of undersirable infrasonic signals. Filter characteristic is third-order Butterworth with -3 dB frequency at 15 Hz. Resistor and capacitor values shown are for 1% tolerance components. 5% tolerance units can be substituted in less critical applications.

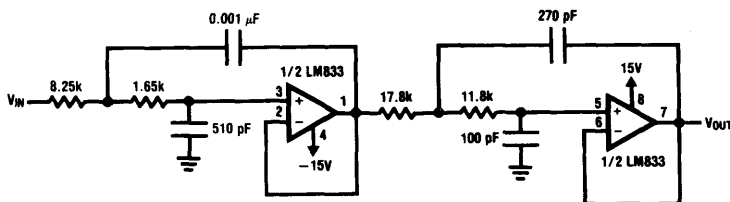

TL/H/5520-12

FIGURE 12. Ultrasonic rejection filter with fourth-order Bessel low-pass characteristic. The filter gain is down 3 dB at about 40 kHz. As with the infrasonic filter, 1% tolerance components should be used for accurate response.

It is important to remember that even a constant voltage crossover transfer function does not guarantee an ideal overall system response, because the transfer functions of the transducers will also affect the overall response. This can be minimized to some extent by using drivers that are "flat" at least two octaves beyond the crossover frequency.

III. INFRASONIC AND ULTRASONIC FILTERS

In order to ensure "perfectly flat" amplitude response from 20 Hz to 20 kHz, many audio circuits are designed to have bandwidths extending far beyond the audio frequency range. There are many high-fidelity systems, however, that can be audibly improved by reducing the gain at frequencies above and below the limits of audibility.

The phonograph arm/cartridge/disc combination is the most significant source of unwanted low-frequency information. Disc warps on $33\frac{1}{3}$ rpm records can cause large-amplitude signals at harmonics of 0.556 Hz. Other large low-frequency signals can be created at the resonance frequency determined by the compliance of the pickup cartridge and the effective mass of the cartridge/arm combination. The magnitude of undesirable low-frequency signals can be especially large if the cartridge/arm resonance occurs

at a warp frequency. Infrasonic signals can sometimes overload amplifiers, and even in the absence of amplifier overload can cause large woofer excursions, resulting in audible distortion and even woofer damage.

Ultrasonic signals tend to cause problems in power amplifiers when the amplifiers exhibit distortion mechanisms due to slew rate limitations and other high frequency nonlinearities. The most troublesome high-frequency signals come principally from moving-coil cartridges and sometimes from tape recorders if their bias oscillator outputs manage to get into the audio signal path. Like the infrasonic signals, ultrasonic signals can place distortion products in the audio band even though the offending signals themselves are not audible.

The circuits in Figures 11 and 12 attenuate out-of-band signals while having minimal effect on the audio program. The infrasonic filter in Figure 11 is a third-order Butterworth high-pass with its -3 dB frequency at 15 Hz. The attenuation at 5 Hz is over 28 dB, while 20 Hz information is reduced by only 0.7 dB and 30 Hz information by under 0.1 dB.

The ultrasonic filter in Figure 12 is a fourth-order Bessel alignment, giving excellent phase characteristics. A Bessel filter approximates a delay line within its passband, so complex in-band signals are passed through the filter with negligible alteration of the phase relationships among the various in-band signal frequencies. The circuit shown is down 0.65 dB at 20 kHz and -3 dB at about 40 kHz. Rise time is limited to about 8.5 μ Sec.

The high-pass and low-pass filters exhibit extremely low THD, typically under 0.002%. Both circuits must be driven from low impedance sources (preferably under 100 ohms). 5% components will often yield satisfactory results, but 1% values will keep the filter responses accurate and minimize mismatching between the two channels. The amplitude response of the two filters in cascade is shown in Figure 13.

When the two filters are cascaded, the low-pass should precede the high-pass.

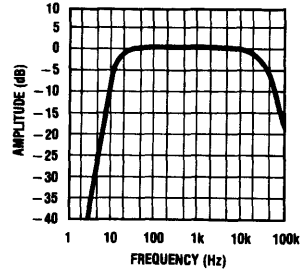

TL/H/5520-13

FIGURE 13. Amplitude response of infrasonic and ultrasonic filters connected in series.

IV. TRANSFORMERLESS MICROPHONE PREAMPLIFIERS

Microphones used in professional applications encounter an extremely wide dynamic range of input sound pressure levels, ranging from about 30 dB SPL (ambient noise in a quiet room) to over 130 dB SPL. The output voltage of a low impedance (200 ohm) microphone over this range of SPLs might typically vary from 20 μ V to 2V rms, while its self-generated output noise would be on the order of 0.25 μ V over a 20 kHz bandwidth. Since the microphone's output dynamic range is so large, a preamplifier for microphone signals should have an adjustable gain so that it can be optimized for the signal levels that will be present in a given situation. Large signals should be handled without clipping or excessive distortion, and small signals should not be degraded by preamplifier noise.

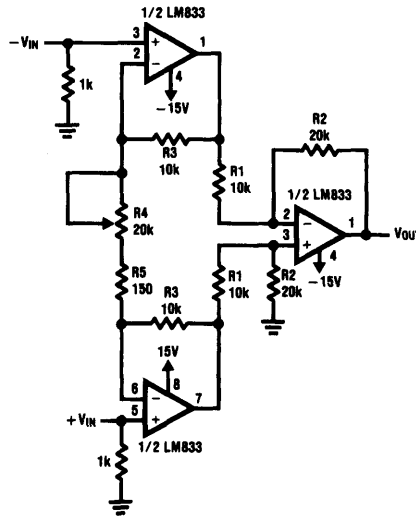

TL/H/5520-14

FIGURE 14. Simple transformerless microphone preamplifier using LM833. R_1 , R_2 , and R_3 are 0.1% tolerance units (or R_2 can be trimmed).

APPENDIX I: DERIVATION OF RIAA PHONO PREAMPLIFIER DESIGN EQUATIONS (1), (2), AND (3).

The first three design equations on the third page are derived here. The derivations of the others should be apparent by observation. The purpose of the preamplifier's first stage is to produce the transfer function:

$$A_V(s) = A_V(\text{dc}) \frac{(3.18 \times 10^{-4} + 1)}{(3.18 \times 10^{-3} + 1)} \quad (\text{i})$$

where $A_V(\text{dc})$ is the dc gain of the first stage.

The actual first stage transfer function is (ignoring C_0):

$$A_V(s) = \frac{sC_1(R_0R_1 + R_1R_2) + R_0 + R_1 + R_2}{sC_1R_0R_1 + R_0} = \left[\frac{R_0 + R_1 + R_2}{R_0} \right] \left[\frac{sC_1 \frac{(R_0R_1 + R_1R_2)}{R_0 + R_1 + R_2} + 1}{sC_1R_1 + 1} \right] \quad (\text{ii})$$

Equating terms, we have:

$$\frac{C_1(R_0R_1 + R_1R_2)}{R_0 + R_1 + R_2} = 3.18 \times 10^{-4} \quad (\text{iii})$$

$$C_1R_1 = 3.18 \times 10^{-3} \quad (\text{iv})$$

$$A_V(\text{dc}) = \frac{R_0 + R_1 + R_2}{R_0} \quad (\text{v})$$

Note that (iv) is equivalent to (2) on page three.

From (iii) and (iv) we have:

$$\frac{C_1R_1(R_0 + R_2)}{R_0 + R_1 + R_2} = \frac{C_1R_1}{10} \quad (\text{vi})$$

Therefore:

$$\frac{R_0 + R_1 + R_2}{R_0 + R_2} = 10 \quad (\text{vii})$$

$$\frac{R_1}{R_0 + R_2} = 9 \quad (\text{viii})$$

$$\text{and } R_2 = \frac{R_1}{9} - R_0 \quad (\text{ix})$$

(ix) is equivalent to design equation (3) on page three.

Combining (v) and (ix),

$$A_V(\text{dc}) = \frac{R_0 + R_1 + R_2}{R_0} = \frac{R_1(1 + 1/9)}{R_0} \quad (\text{x})$$

Finally, solving for R_1 and using $A_V(\text{dc}) = 8.9535A_V(1 \text{ kHz})$ yields:

$$R_1 = \frac{R_0 A_V(\text{dc})}{10/9} = 0.9R_0 A_V(\text{dc}) = 8.058A_V(1 \text{ kHz}) R_0, \quad (\text{xi})$$

which is equivalent to (1) on page three.

APPENDIX II: STANDARD E96 (1%) RESISTOR VALUES

Standard Resistor Values (E-96 Series)							
10.0	13.3	17.8	23.7	31.6	42.2	56.2	75.0
10.2	13.7	18.2	24.3	32.4	43.2	57.6	76.8
10.5	14.0	18.7	24.9	33.2	44.2	59.0	78.7
10.7	14.3	19.1	25.5	34.0	45.3	60.4	80.6
11.0	14.7	19.6	26.1	34.8	46.4	61.9	82.5
11.3	15.0	20.0	26.7	35.7	47.5	63.4	84.5
11.5	15.4	20.5	27.4	36.5	48.7	64.9	86.6
11.8	15.8	21.0	28.0	37.4	49.9	66.5	88.7
12.1	16.2	21.5	28.7	38.3	51.1	68.1	90.9
12.4	16.5	22.1	29.4	39.2	52.3	69.8	93.1
12.7	16.9	22.6	30.1	40.2	53.6	71.5	95.3
13.0	17.4	23.2	30.9	41.2	54.9	73.2	97.6