



Studio 200 Stereo Control Unit, Pt.2

Last month, we introduced our new high performance stereo control unit and described the circuit operation. This month, we present the construction and troubleshooting details.

By GREG SWAIN & BOB FLYNN

Because the circuit of the Studio 200 control preamp is so simple, it follows that the construction is also straightforward. Most of the work involves mounting components on three printed circuit board assemblies. These are for the power supply, the phono preamplifier, and the tone control and headphone amplifier circuitry.

There is very little wiring inside the chassis. This is because all the pots, the headphone socket and the pushbutton switches (but not the mains switch) are mounted directly on the tone control board. Similarly, the rotary input selector switch is mounted on a small PCB which is then soldered at right angles to the phono preamp board.

Mounting the switches and pots in this way eliminates the tedium of running separate leads to the terminals of these components. It also

greatly reduces the possibility of wiring errors. So the Studio 200 is easy to build.

Collecting the parts

While some constructors will prefer to buy the parts separately, most will elect to buy a complete kit of parts. Because all the parts are readily available, there is nothing to stop you from adopting either approach.

Buying a complete kit is probably the easiest option. We understand that at least two kitset suppliers, Altronic and Jaycar Electronics, will be selling kits for this project. Both the Altronic and Jaycar kits will come with pre-punched chassis and the front panel labelling will be silk-screened.

If you do elect to go it alone, you should have little difficulty in buying the parts separately. The only

parts that might cause constructors some problems are the extension shaft (1/4-inch rod) and shaft coupler for the selector switch and the accompanying 1/4-inch ID x 3/8-inch bush. This latter component mounts on the front panel. If you have difficulty locating this bush, it's quite easy to salvage one by wrecking a potentiometer from your junkbox.

The PCBs will be available separately from RCS Radio in Sydney, Jemal Products in Perth, and from Marday Services in Auckland, New Zealand (see page 96 for addresses). Alternatively, you may choose to etch your own boards using the patterns published with this article.

To simplify matters, we'll assume that you've purchased a complete kit of parts and that you have the standard one-unit rack case as supplied by Altronic.

Starting construction

The first job is to partially assemble the rack mounting case. This is supplied as a kit and consists of four rails, the top and bottom panels, and the front panel. Note that the top and bottom panels are

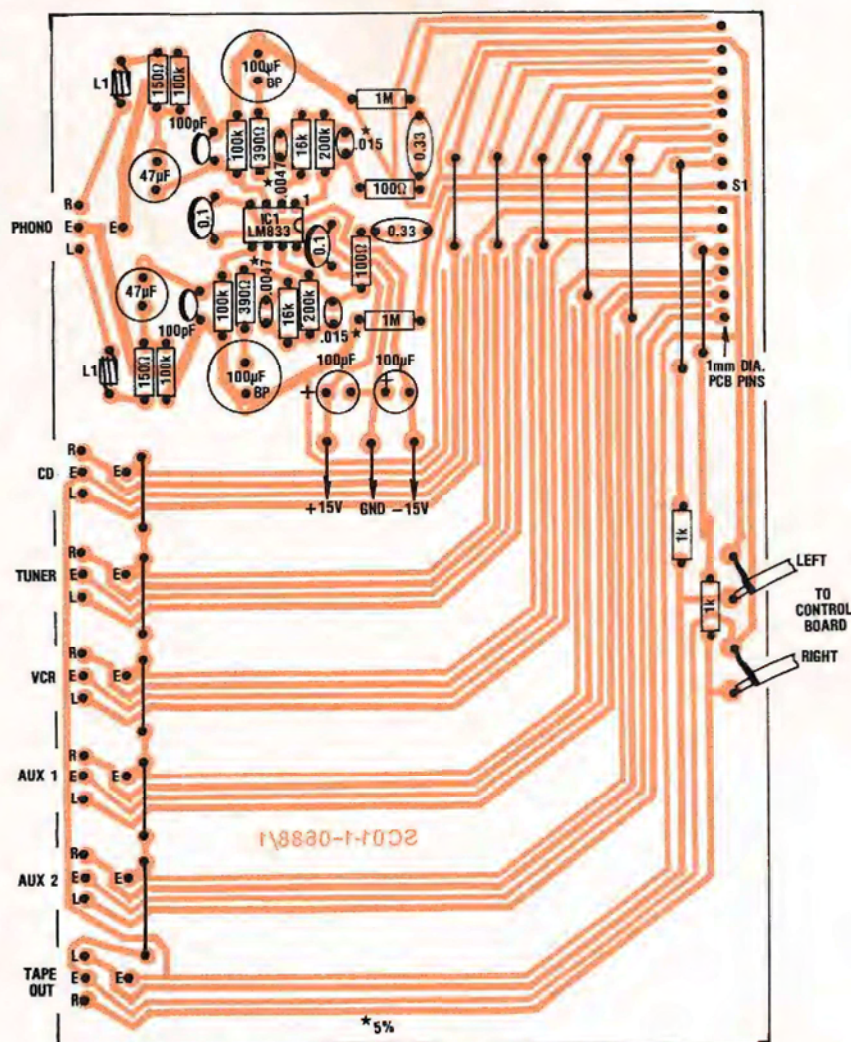

Fig.4: parts layout for the phono preamplifier board. Note that all the resistors in the phono preamp, except for the 100Ω and 1MΩ values, should be 1% metal film types. Take care with the orientation of the IC.

swapped over for this project, so that the slotted panel becomes the base and the solid panel becomes the top.

To assemble the case, first attach

the front and rear rails to the base. These two rails are secured by means of screws which screw into captive nuts on the flanges. Note that the captive nut in the centre of

one of the flanges has been drilled out to provide clearance for the tone control PCB. This flange goes towards the top, front of the case.

Once the front and back rails are in position, the side rails can be attached using the screws and nuts supplied (slotted screws towards the rear, countersunk Allen screws towards the front). Leave the front panel off at this stage and note that the side rail that carries the switch bracket is mounted on the right hand side of the chassis.

The 18 insulated RCA sockets and the binding post terminal can now be installed on the rear panel. Orient the earth lugs on the RCA sockets as shown in Fig.9 and don't forget the solder lug on the binding post terminal. A multimeter should be used to check that each RCA socket is correctly isolated from the chassis.

Incidentally, although we used screw-linking gold-plated RCA sockets in our prototype (which you may have noticed from last month's cover photo), we recommend the use of standard nickel-plated insulated chassis mounting sockets. We suggest Arista RCA3I sockets which are supplied with white nylon insulators.

You can now place the chassis to one side and turn your attention to the PCB assemblies.

Phono preamplifier PCB

This board is coded 01106881 and carries the parts for the phono preamplifier. It also carries five sets of stereo tracks which run between the RCA input sockets on the rear panel and the selector switch

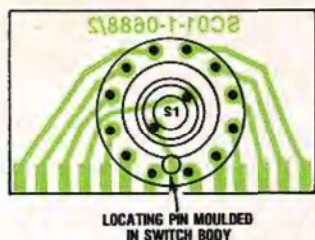

Fig. 5: the selector switch should be mounted on its PCB with the locating pin towards the bottom. Check the PCB pattern carefully to ensure that none of the input pads are shorted together.

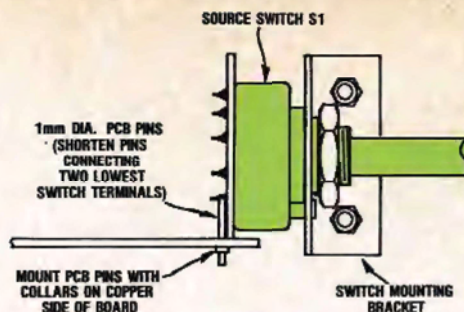

Fig. 6: mounting detail for the selector switch assembly. Note that the PCB pins must be installed with their collars on the copper side of the phono preamplifier PCB.

at the front of the board. An additional set of stereo tracks run from the selector switch back to the Tape Out socket.

Before mounting any of the parts, it is a good idea to carefully check the copper pattern on the underside of the board. You should especially check for shorts between the long parallel tracks to the selector switch.

Don't just rely on a visual check here — switch your multimeter to a high ohms range and use it to confirm that the tracks are isolated from each other. This test will quickly locate faults on any board that has not been correctly etched.

Fig. 4 shows the parts layout for this PCB. The first job is to install the 21 PC pins. Fourteen of these support the selector switch assembly and these should be installed from the copper side of the

PCB (see Fig. 6). Another three PC pins are required for the power supply connections near the centre of the board (+ 15V, 0V and - 15V), while the four remaining pins are located at the left and right channel outputs (adjacent to the 1k Ω resistors).

No particular order need be followed when installing the remaining parts on the board but it's best to start with the smaller parts (resistors and wire links) first. Note that all the resistors in the phono preamplifier, except for the 100 Ω and 1M Ω values, are close-tolerance 1% metal film types (see circuit). They have been specified for low noise and their close tolerance values.

Check the values on your multimeter before installing them on the board — it's all too easy to misread the colour codes.

You should also note that four of the capacitors (two in each channel) are marked with an asterisk. These capacitors are in the feedback network of the phono preamplifier and should be close tolerance (5% or better) types in order to obtain accurate RIAA equalisation.

If you have a capacitance measuring function on your digital multimeter you can specially select these capacitors. If you are buying a kit, the kitset suppliers may elect to supply 5% capacitors or may also hand select the capacitors.

Be warned that some close-tolerance capacitors may not fit the board unless you bend their pigtailed. Don't feel cheated if you are supplied with hand-selected greencaps instead of 5% close tolerance types. The hand selected types will work just as well.

Take care with the orientation of the IC and the electrolytic capacitors. The two input inductors are

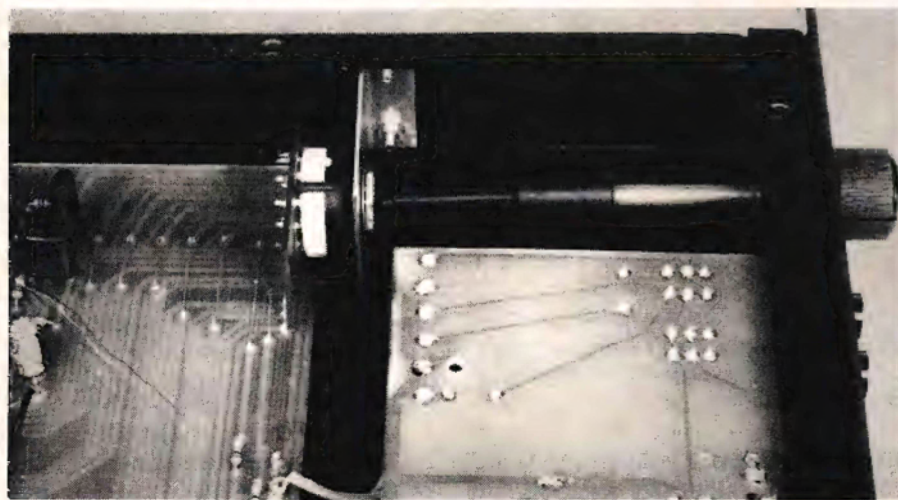

The switch assembly is soldered at right angles to the phono preamplifier PCB and supported by an L-shaped bracket secured to the side rail. The switch shaft is lengthened using an extension shaft and coupler.

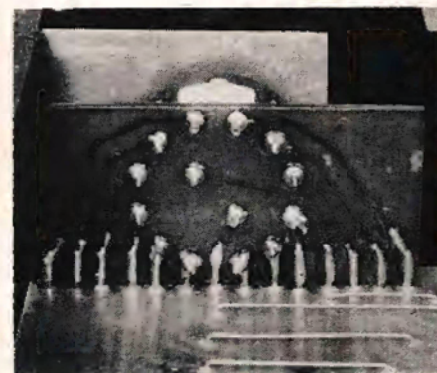

Above: rear view of the selector switch PCB. You may have to shorten two of the PC pins to stop them fouling the switch terminals.

each made by winding 4-1/2 turns of 0.6mm enamelled copper wire on an FX1115 ferrite bead. Scrape the enamel from the ends of the leads before soldering the inductors to the PCB.

Construction of the phono pre-amplifier PCB can now be completed by soldering 28 40mm lengths of tinned copper wire to the input pads along the back of the board. These input leads will later be soldered to the RCA input connectors along the rear panel.

Selector switch assembly

Figs.5 & 6 show the mounting details for the selector switch. Position the switch with the locating pin towards the bottom and push the body of the switch all the way down onto the board before soldering the terminals.

The pads along the bottom edge of the switch board can now be soldered to the 14 PC pins on the phono preamplifier board (see Figs.6 & 9). It will be necessary to shorten two of these pins to stop them from fouling the two lowest switch terminals.

At this stage, you're ready to mount the phono preamplifier assembly in the case. This assembly is supported at the front by the switch mounting bracket and at the rear by the tinned copper wire connections between the PCB and the RCA sockets. Together, these provide ample support for the assembly and eliminate the need to secure the board via mounting pillars to the bottom panel.

It also means that the bottom panel can be easily removed for inspection of the underside of the PCB or for other work.

To mount the assembly, slide the L-shaped bracket over the switch shaft (see Fig.6), then position the PCB inside the case and fasten the switch bracket to the right hand rail with machine screws and nuts. This done, attach the extension shaft to the switch shaft using the shaft coupler.

The extension shaft must now be centred in the hole in the front panel. You will find that the mounting hole in the L-shaped bracket has been slotted so that the PCB assembly can be slid sideways to locate the centre position. Check

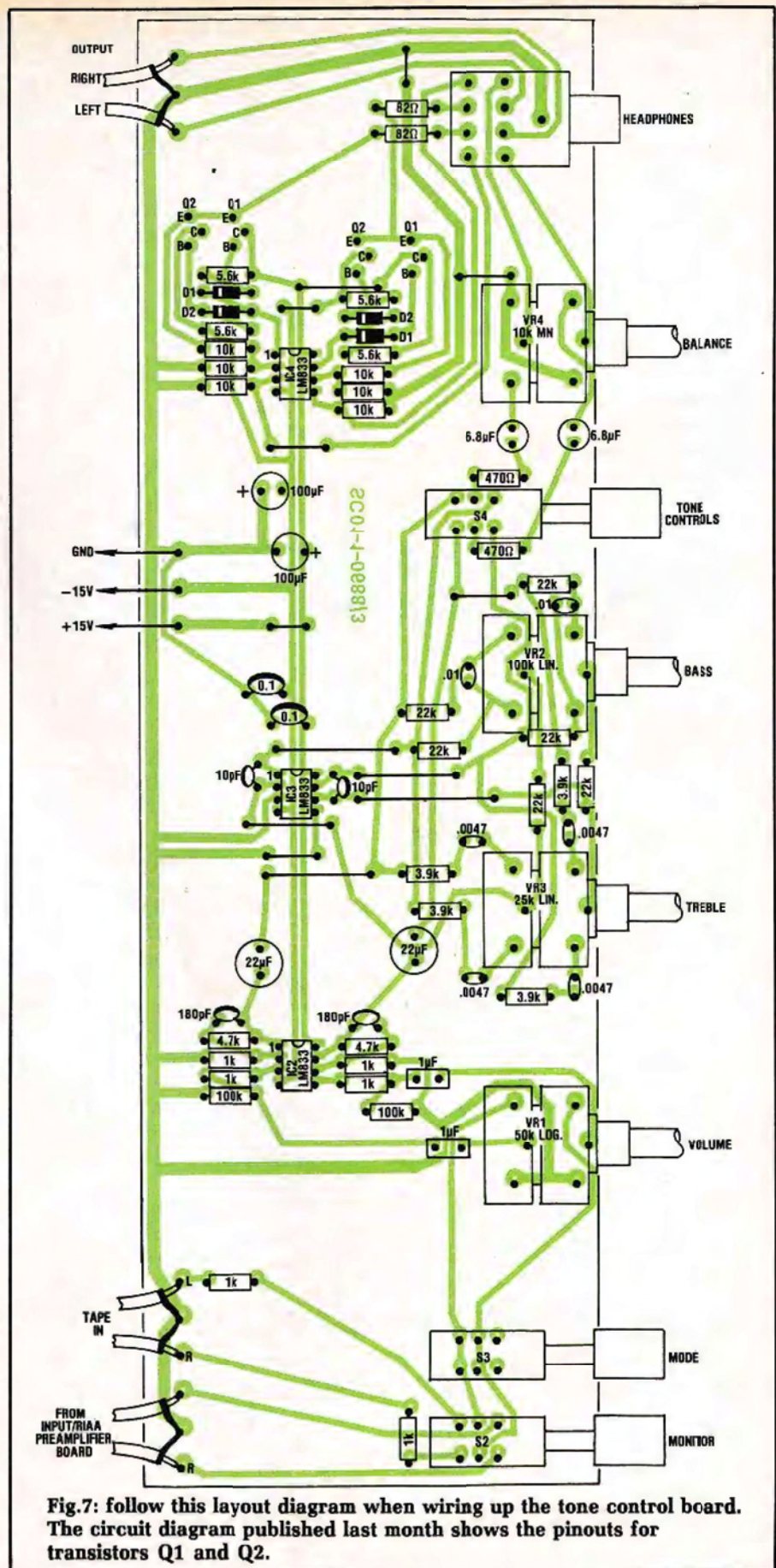
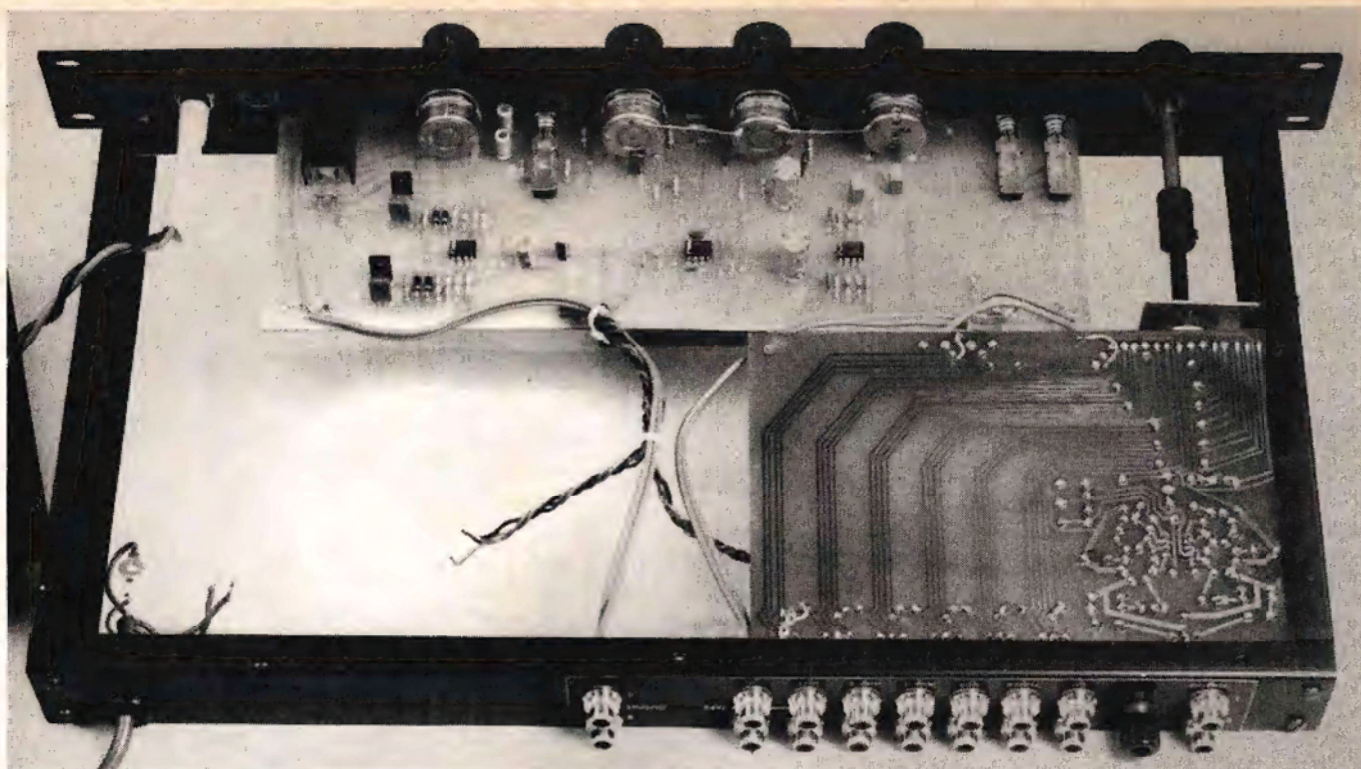

Fig.7: follow this layout diagram when wiring up the tone control board. The circuit diagram published last month shows the pinouts for transistors Q1 and Q2.



This is an underside view of the control unit with the bottom panel removed. The links between the pots are not necessary but make sure that they are electrically in contact with the chassis.

that the preamplifier PCB is parallel to the bottom of the case before doing up the switch mounting nut to lock the assembly into position.

Before wiring up the RCA sockets, it will be necessary to provide some sort of temporary support for the left hand side of the board. A 5mm drill bit is ideal for this purpose. Slide the drill bit under the board, then wire up the RCA sockets as shown in Fig.9. Bend the leads as shown in the photograph so that they are well clear of each other and don't forget to remove the drill bit when you have finished.

Tone control PCB

Fig.7 shows the parts layout on the tone control PCB (code 01106883). Commence assembly by installing PC pins at the external wiring points, then install the wire links, resistors, capacitors and semiconductors.

Check the orientation of polarised parts carefully when installing them on the board. These parts include the three ICs, four diodes, four transistors and electrolytic capacitors. The 6.8 μ F and 22 μ F

capacitors are bipolar types and can be installed either way around.

The headphone socket, pots and pushbutton switches should be left till last. Be sure to push them all the way down onto the board but don't solder all the leads at this stage. Instead, tack solder diagonally opposite pins at either end of each component.

The tone control assembly can now be tested in the front rail to ensure that everything aligns properly. To do this, it is best to remove the bottom panel so that you will have access to both sides of the board. Adjust the alignment of the pots and switches as necessary before removing the board and soldering the remaining pins.

Note that it may be necessary to shorten the front row of pins on each pot to prevent fouling of the top flange. It may also be necessary to snip off the top of the Bakelite insulating section of each pot using a pair of sidecutters to give clearance for the bottom flange. Be careful doing this. You don't want to butcher the pot and damage its carbon tracks.

That completes the tone control board. It can now be permanently

mounted on the front rail and secured using the pot nuts and lockwashers. But before mounting the tone control board to the front rail, take a round file and lightly remove the anodised coating around each potentiometer hole.

The idea of doing this is to make sure that the metal case of each pot is electrically connected to the chassis. If you don't do this you may end up with a slight background hum or buzz which may worsen when you touch the control itself.

When all pot nuts are secured, use your multimeter to check that all the pot cases are electrically connected together, via the front rail. Check also that there are no shorts between the top flange and soldered connections on the PCB.

You should also check that the headphone socket, pots and switches are centred correctly in the clearance holes in the front rail. If everything is correct, you can go ahead and run the shielded cable leads as shown in Fig.9. These leads go to the phono preamplifier board and to the TAPE IN and OUTPUT sockets on the rear panel.

Finally, connect the two sets of power supply leads to the +15V,

0V and -15V terminals. We suggest that you use red cable for the +15V lead, green for the 0V lead and black for the -15V lead. Twist the leads together as shown in the photographs before making the connections to the phono preamplifier board.

The other set of leads are later connected to the power supply board. Make the leads about 100mm long and leave them floating for the time being.

Power supply PCB

This PCB is coded 04106881 and is used to provide the $\pm 15V$ rails for the circuit. Fig.8 shows the location of the various parts.

The main thing to watch out for here is the orientation of the diodes and the two 3-terminal regulators. Be careful not to confuse the regulators and check that their metal tabs both face in the same direction. Install PC pins at all external wiring points.

The supply PCB can now be mounted on the bottom panel, along with the power transformer, mains terminal block and earth solder lugs (see Fig.9). The supply board is mounted on 6mm standoffs and secured using machine screws and nuts. Two brass nuts, one on each mounting screw, are used to stand the transformer off the chassis.

Once all the items of hardware have been mounted, the bottom panel can be re-attached to the chassis.

Mains wiring

Take great care with the mains wiring — your personal safety depends on it.

Fig.9 shows the mains wiring details. The mains cord enters through a hole in the rear panel and is securely clamped using a cord-grip grommet. Strip back the outer sheath of the mains cord by about 35mm before connecting the active (brown) and blue (neutral) leads to the mains terminal block. The earth lead (green/yellow) is soldered to one of the adjacent solder lugs.

The second solder lug terminates an earth lead which is run along the rear panel from the binding post terminal adjacent to the phono input sockets. Don't alter the earth

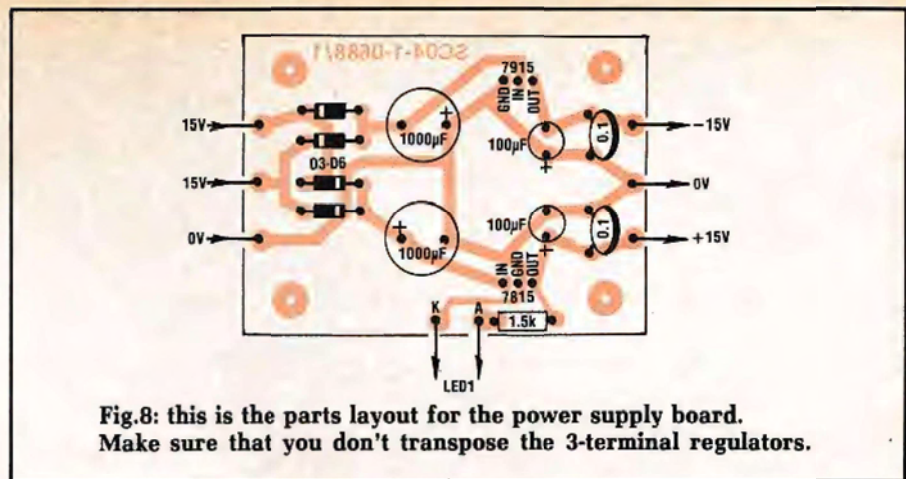

Fig.8: this is the parts layout for the power supply board. Make sure that you don't transpose the 3-terminal regulators.

wiring — you may get a hum loop if you do.

The primary leads of the transformer are connected to the mains terminal block while the 15V secondary and centre-tap leads are soldered to three PC pins on the power supply board.

Final assembly

The front panel can now be mounted but be careful — one scratch and you'll ruin the appearance of the whole project. Secure the front panel at both ends using the Allen screws then install the power switch, the LED and the bush for the switch shaft. The bush is secured using locking nuts installed on both sides of the front panel.

Be sure to use mains-rated 240VAC cable for the connections to the power switch. We used heat-

shrink tubing to cover the switch lugs and then covered the whole switch body up to the threaded section with a larger piece of heat-shrink tubing.

The other ends of the leads from the mains switch go to the terminal block, along with a .01µF 250VAC "anti-thump" capacitor. Make sure that this capacitor is rated at 250VAC.

The connections to the LED were also covered with heatshrink tubing. The LED is secured to the front panel by means of a small plastic bezel. Connect the leads from the LED to the power supply board but don't connect the leads to the supply pins (+15V, 0V and -15V) until the supply has been fully tested.

Testing

Check your power supply wiring

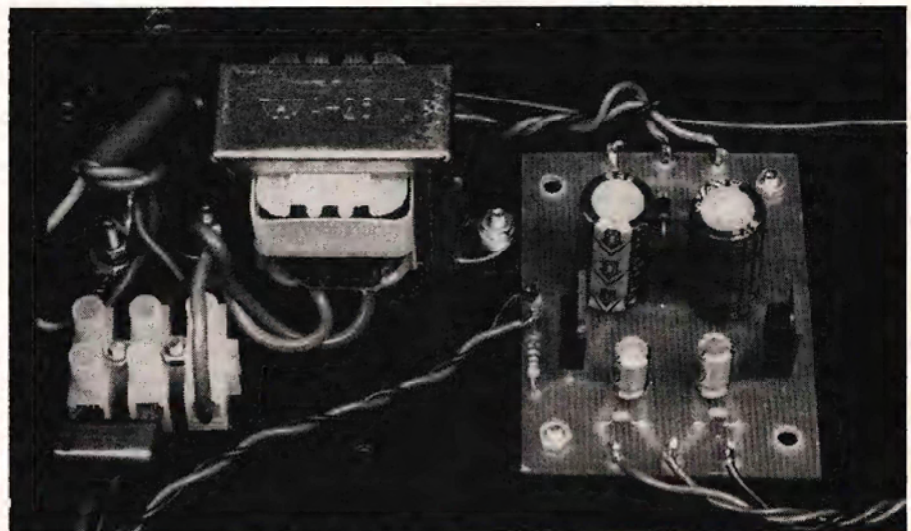

This is a close-up shot of the power supply components. Note the .01µF 250VAC capacitor connected across the mains switch, at the 3-way insulated terminal block. The transformer is spaced off the chassis using brass nuts.

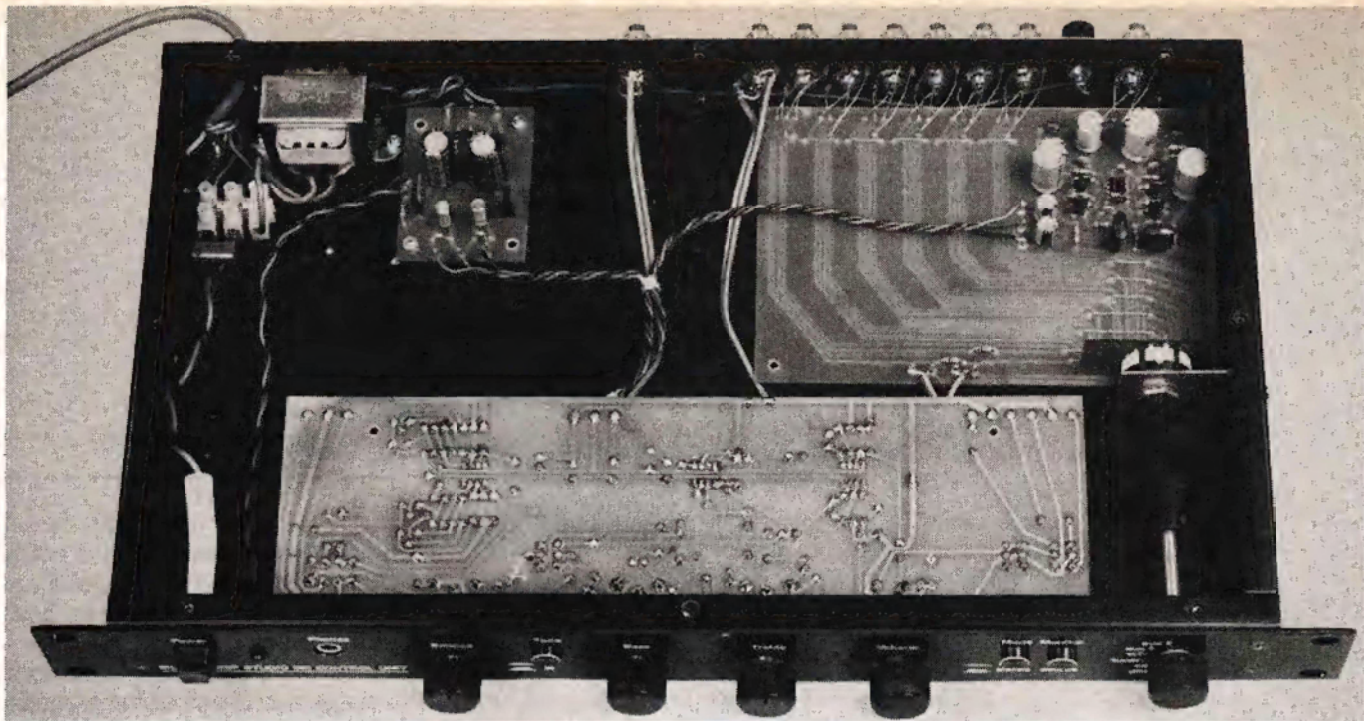

The new control unit has very little point-to-point wiring. This has largely been made possible by running the input signals via copper tracks on the phono preamplifier board at top right.

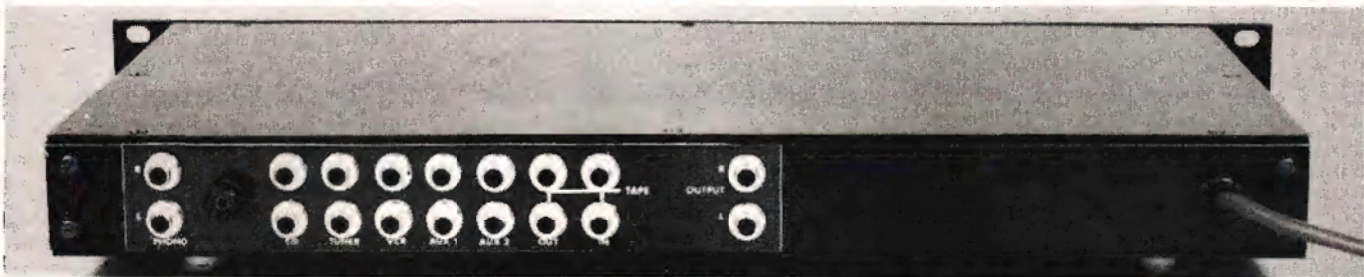

The rear panel carries the RCA input and output sockets, an earthing terminal and the mains cord grommet.

carefully, then switch on and use your multimeter to check the +15V and -15V outputs on the power supply board. The LED should also be lit; if not, you may have connected its leads the wrong way around.

If these checks are OK, the supply leads from the tone control board can be connected to the power supply board. A number of voltage checks can now be made. Connect the negative lead of the multimeter to the 0V terminal on the power supply board and check that +15V is present at pin 8 of each of the four LM833s.

Similarly, check that -15V is present at pin 4 of each IC. That being the case, measure the voltage at pin 1 and pin 7 of each of the ICs. In each case, it should be within $\pm 10\text{mV}$ of the 0V rail.

You can also check that +15V is present at the collector of Q1 and that -15V is present at the collector of Q2. Finally, there should be almost 0V at the junction of the emitters of Q1 and Q2 (ie, within $\pm 10\text{mV}$ of 0V).

Troubleshooting

If the above measurements are not OK, the most likely causes are broken tracks or solder bridges between IC pins. For example, if you have the correct supply voltages on an IC but its output is close to +15V or -15V, it is most likely that there is a break in the feedback network or the inputs to that IC.

You can follow this up by measuring the voltage at the input pins of the ICs. Again, these should all be very close to 0V. If not, check

for breaks in the copper track or poor solder joints; or that the IC is in the wrong way around.

Note: if you've put the IC in the right way around, it is most unlikely that any malfunction will be due to a faulty IC.

Put the knobs on now and we're ready for the next test.

Listening tests

No, we're not going to listen to music — yet. The idea of the next few checks is to make sure that everything is really working as it should. You'll need a pair of headphones. Plug 'em into the headphone socket, turn on the power and listen.

With the Volume control at minimum setting you shouldn't be able to hear anything. If you now select the phono input and wind up

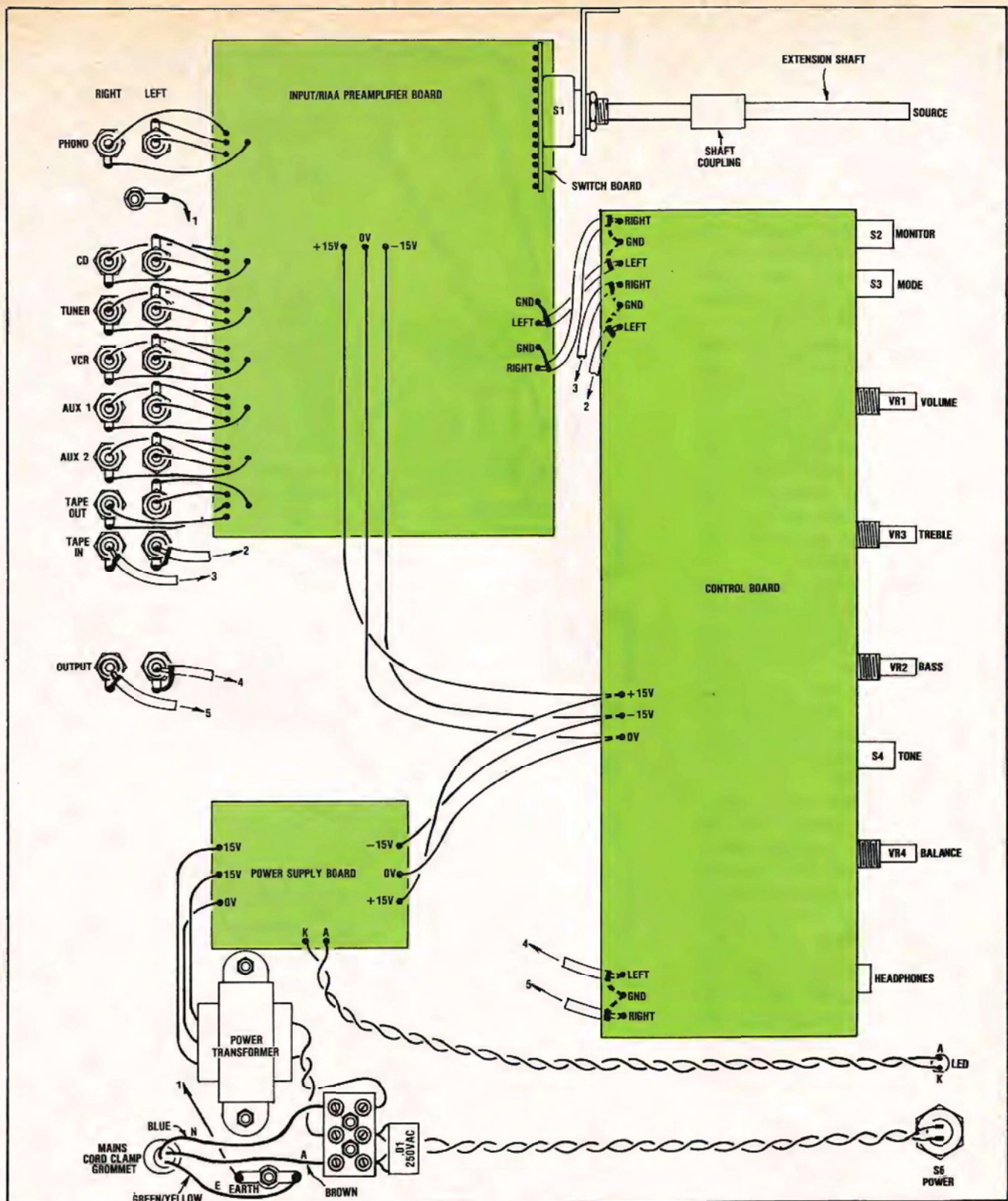

Fig.9: the complete wiring layout of the control unit. Note that there is no direct connection between the signal earth and the mains earth. This is done to avoid hum loops.

the Volume to maximum, you will hear some hiss and quite a lot of hum. That is normal (because the phono inputs are floating).

Turn off the power and connect a short jumper lead between the solder lug of the binding post terminal and the earth lug of one of the

phono inputs. This connects all the control unit's circuitry earth to the chassis. Normally, there should be no connection at this point other-

wise there will be an earth loop when the power amplifier is connected (assuming that the power amplifier itself is earthed).

Now turn on the power again, and wind up the Volume control, still with the phono input selected. There now should be no buzz or hum but there will be some hiss. Again, this is normal. If you now switch to the other inputs (CD, tuner, etc) the noise should drop to extremely low levels (we doubt you'll be able to hear anything, even in a very quiet room).

If you now plug a pair of shorting plugs into the phono inputs, the noise on the phono inputs should drop to much lower levels. Good. Pull the shorting plugs, wind up the Volume control and then check the action of the Bass and Treble controls. The Treble control should boost and cut the hiss and the bass control should boost and cut the low frequency phono noise.

The Balance control should also shift the noise from left to right and the Mono/stereo switch should also work; when in the mono setting the noise should appear from right in the centre of your head. Switching to Tape Monitor should kill the noise and the Tone Defeat switch should kill any boost and cut effect of the tone controls.

Now if all of these things don't check out, it is pretty easy to localise the fault to a particular section. For example, let's suppose that there is no noise on the phono inputs, but very faint noise on the CD and other inputs. OK, that means a fault in the phono preamplifier but provided the voltage measurements here were correct, then you probably have an open circuit between the phono LM833 output(s) and the selector switch.

In the event that the headphone outputs don't work at all, meaning you don't get to first base, you can connect the headphones to the main control unit outputs. You'll need some jumper leads or a pair of RCA plug to 6.5mm socket adaptor leads to do this.

However, don't let the foregoing procedure give you the impression that this control unit is hard to get going. On the contrary. At the time

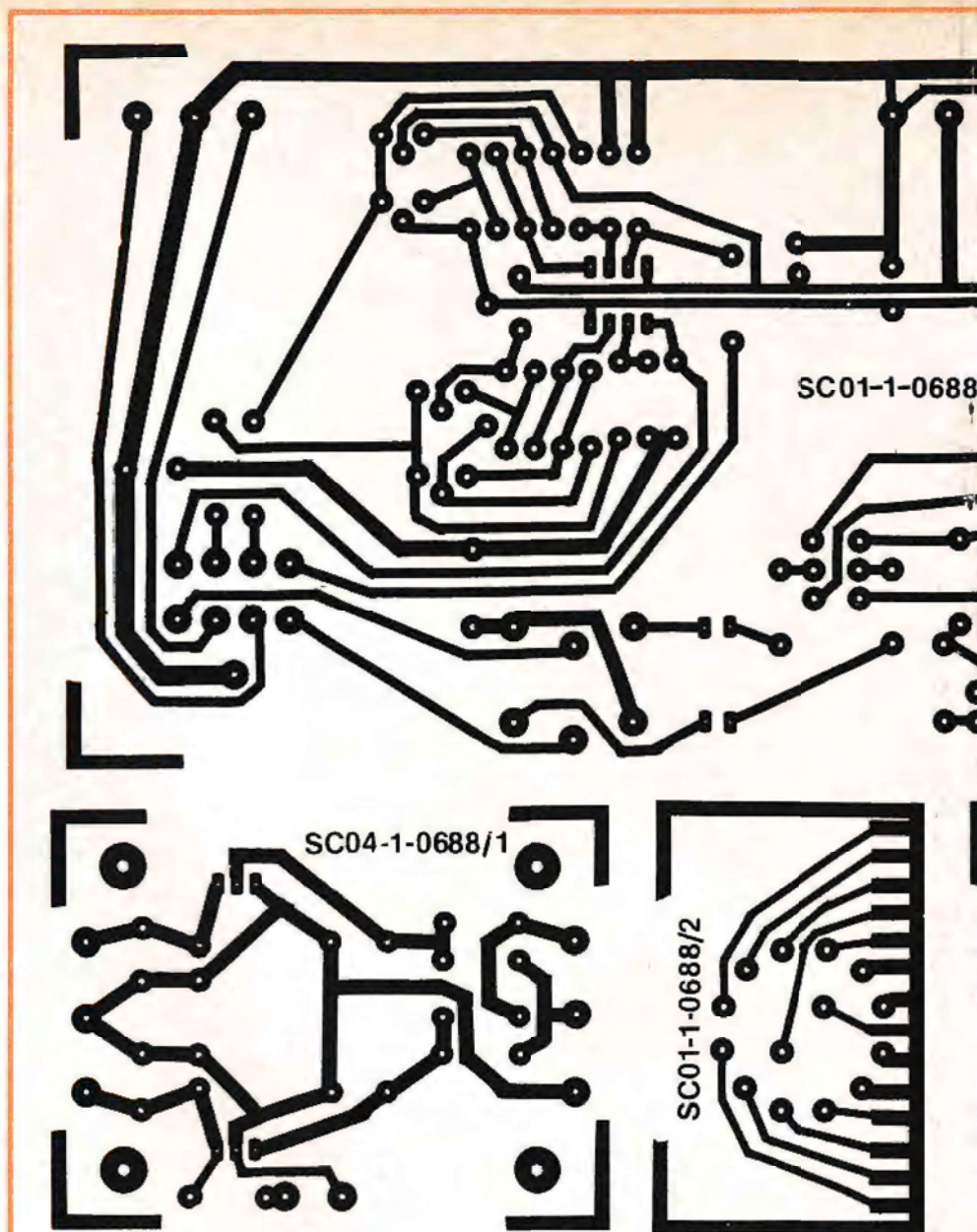

Fig.10: these are the full size patterns for the four printed circuit boards of the control unit.

of writing we had built two prototypes and they both worked perfectly, first time. If you haven't made any wiring errors, your's will too.

With all checks complete, remove the earth jumper lead from the phono socket and attach the lid of the case. You are now ready to connect the power amplifier and speakers.

You can stack the control unit on top of or below the power amplifier but for the absolute lowest noise figures, keep the control unit as far

away from the power amplifier as is practical.

For lowest noise and hum, the power amplifier should be earthed back to the mains earth via a conventional 3-core power flex and 3-pin mains plug. If you have built the Studio 200 power amplifier this will already be the case. Your system will be quiet, really quiet. And it will sound great.

Footnote: 100mm of 0.6mm enamelled copper wire should be added to the parts list published last month.

