

Wideband noise reducer

Cost-effective i.e. design pumping effects with pre-emphasis

by D. L. Harrison B.Sc.(Eng)

The noise reduction system described can yield a wideband reduction of tape recorder noise of about 30dB. A compander integrated circuit forms the heart of the system and judicious use of pre-emphasis and de-emphasis reduces noise pumping effects.

ONCE OPTIMIZED for the signal levels in a particular installation the noise reduction provided by this circuit is dramatic. From a hissy, hummy tape output one can enjoy absolute silence during quiet passages without, in my opinion, noticeably degrading the music programme. The system does not use r.m.s. signal detection, as does the dbx system, but I feel that r.m.s. signal detection, whilst it does offer some advantages, is not the panacea it is often made out to be. It is less sensitive to phase errors in the channel compared with average signal detection. Admittedly the tape medium is notorious for introducing phase errors that could lead to compander mistracking if r.m.s. detection is not used. However r.m.s. detection is more susceptible to h.f. amplitude response errors than average signal detection* a fact rarely mentioned by the proponents of r.m.s. detection. It would seem, therefore, that r.m.s. versus average detection is something of a "swings and roundabouts" situation. Considering that the cost of the system here is about one tenth that of a dbx system and that the results are impressive. I feel a really cost-effective design has been achieved.

A problem which has plagued simple compressors in the past has been that of noise pumping. When the average value of the signal is high as at A in Fig 1 the expander gain is also high and so the background noise signal is amplified. However this noise is generally not heard because of the masking effect of the signal. At B, however, the average value of the signal has dropped, i.e. a very quiet passage following a very loud passage of music. The expander is unable to change its gain instantaneously and so due to this fall back time the gain

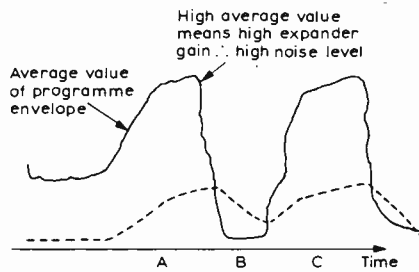

Fig. 1. Simple compressors are unable to respond instantaneously to a fall in signal level, giving rise to obtrusive changes in noise level.

is high whilst the signal is of a low level and thus the noise can be clearly heard. This is a serious shortcoming of the simple compressor because a noise level of varying amplitude which is pumped up and down by the signal level has a greater annoyance value than a steady noise level.

Fortunately the effect of this noise pumping can be subjectively reduced by including signal pre-emphasis before compression and de-emphasis after expansion. This is the method adopted by dbx Inc and by the system presented here. In this particular design a pre-emphasis of +12dB starting at about 500Hz is used. This does not eliminate noise pumping but reduces the high frequency noise by 12dB and renders it inaudible under normal listening conditions. On compression this 12dB lift becomes 6dB which is passed to the tape recorder.

Now unfortunately if one is recording at levels of about -10 to 0 VU there is very little headroom until tape saturation is reached and even less at the higher frequencies. Thus 6dB lift at frequencies above about 2kHz could very easily lead to high frequency tape saturation. This may be counteracted by including pre-emphasis in the signal detector path as shown in the system block diagram. The particular design here uses a detector pre-emphasis of +20dB starting at about 1.6kHz, in common with the dbx system. Curve (a) of Fig 2 shows the signal pre-emphasis whilst curve (b) shows the overall frequency response of a compressor combining the two amounts of pre-emphasis. At frequencies above about 2kHz the recorded signal level actually reduces.

A further problem akin to noise pum-

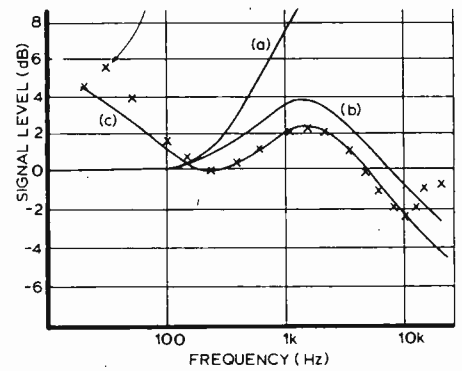

Fig. 2. Effect of noise pumping is reduced by using pre-emphasis (curve a) prior to compression and corresponding de-emphasis on expansion to reduce h.f. noise by 12dB. Possibility of tape saturation is alleviated by adding pre-emphasis in the detector path, as in the dbx system, giving combined result of curve b. Low frequency pre-emphasis, included in curve c helps to reduce audibility of hum signals.

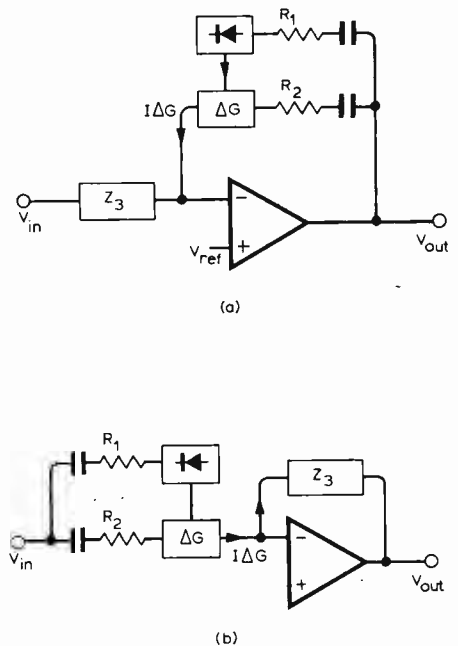
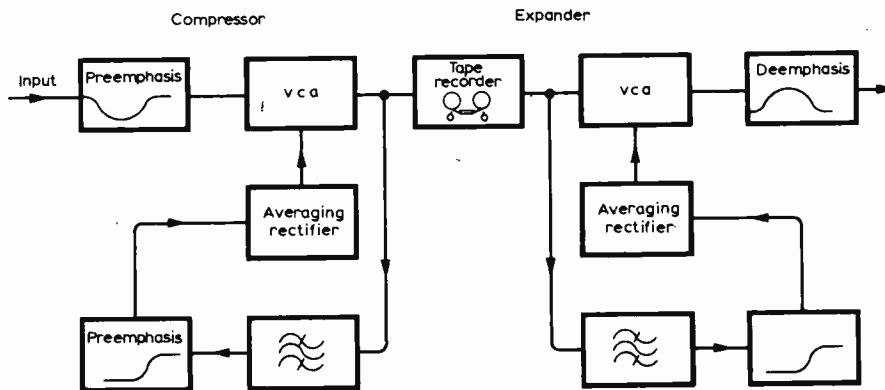

Fig. 3. Variable-gain circuit in compressor (a) and expander (b) provides signal current into the op-amp whose amplitude is proportional to the average of the current flowing in the rectifier circuit.

*M. G. Duncan, D. Rosenberg, & G. W. Hoffman. *Journal of the Audio Engineering Society*. Oct. 1975, vol. 23. Design criteria of a universal compander for the elimination of audible noise in tape, disc, and broadcast systems.

State of the art cassette tape decks costing say, £700, can offer a dynamic range of about 60dB, but a more realistic figure for machines which the majority of us are able to afford is about 45-50dB. As the signal-to-noise ratio of good quality discs played using high quality electronics can be about 60dB, f.m. broadcasts can be as good as 70dB, and live material can have a dynamic range exceeding 100dB, one must ensure that programme peaks do not cause tape saturation, thus losing the lower end of the dynamic range amongst the noise.

This problem has been addressed by many workers in recent years and the solution, in one form or another, is to use signal compression before recording and complementary expansion on playback. Possibly familiar is the Dolby B system for domestic use, providing up to 10dB reduction in noise frequencies above about 2kHz. Whilst a 10dB reduction is certainly worthwhile the remaining noise is still audible when listening at realistic sound levels. A more recent system, introduced by dbx Inc, yields improvements of 30dB and subjectively reduces noise to below audibility. Excellent though it may be, the system is still very expensive and so a circuit was designed with the aim of approaching the dbx performance but which was well within the scope of the amateur



constructor.

The circuit achieves noise reduction by wideband compression and expansion. The compressor contains a voltage controlled amplifier (v.c.a.) whose gain is inversely proportional to the average value of its output voltage, i.e.

$$G = \frac{k_1}{V_{out(av)}} = \frac{k_1}{GV_{in(av)}}$$

$$\therefore G = \left(\frac{k_1}{V_{in(av)}} \right)^{1/2}$$

The gain of the v.c.a. is controlled by the d.c. output of an averaging rectifier stage whose output is proportional to the average value of its alternating input voltage. If input V_{in} changes by, say, +20dB then the gain will change by -10dB thus the output will increase by only +10dB. Square-law expansion is the exact complementary process. i.e. $G = k_2 \times V_{in(av)}$ thus an input change of +10dB will cause the gain to increase by +10dB and the output to increase by +20dB.

ping is that of hum pumping. This arises when the playback signal from the tape recorder contains an audible hum component. This hum signal will also be pumped up and down in level by the signal. Now whereas a high level signal will effectively mask a high frequency noise component the same is not true for a low frequency noise component (hum) hence hum pumping is subjectively even more annoying than h.f. noise pumping. This problem is eased by the use of low frequency pre-emphasis and curve (c) in Fig. 2 shows the overall compressor frequency response of the final circuit. Note that the end-to-end frequency response of the compressor and expander combination is flat since their frequency responses are complementary to each other.

In any compander system the bandwidth of signals presented to the device which measures signal level and hence controls signal gain should be the same in expand mode as in compress mode. From any high quality music source the bandwidth could be up to 20kHz whilst a low quality cassette tape recorder may have a bandwidth of only 10-12kHz. Such a mismatch means that the signals seen by the rectifier circuit are not identical on record and playback. Since most of the energy of music signals is contained in frequencies below 10kHz a 20Hz-to-10kHz bandpass filter is included in the signal feed to the rectifier to prevent this bandwidth mismatch. The lower filter frequency of 20Hz ensures that subsonic signals such as

turntable rumble or acoustic pickup from passing heavy goods vehicles do not cause rectifier mistracking. The compander integrated circuit used is the Signetics NE570 which contains a stereo pair of compander circuits. Each half of this chip contains an operational amplifier, a variable gain cell and an averaging rectifier circuit. The variable gain cell can be thought of as the v.c.a. but it provides a signal current into the summing node of the op-amp whose amplitude is proportional to the average amplitude of the signal current flowing into the rectifier circuit. The relationship, with symbols as in Fig. 3(b), is

$$\frac{V_{in(av)}V_{in}}{70\mu A \times R_1 R_2} \dots \dots \dots (1)$$

The basic configuration of the NE570 in both compress and expand modes is given in Fig. 3. In compress

$$V_{in} = Z_3 I_{DG} \text{ (considering magnitudes only)}$$

and V_{in} in equation 1 becomes $V_{out(comp)}$

$$\therefore V_{in} = \frac{Z_3 V_{out(av)} V_{out}}{70\mu A \times R_1 R_2}$$

If we write $V_{out} = GV_{in}$

$$\text{then } \frac{V_{out}}{V_{in}} = G = \frac{70\mu A \times R_1 R_2}{Z_3 G V_{in(av)}}$$

$$\therefore G = \left(\frac{70\mu A \times R_1 R_2}{Z_3 V_{in(av)}} \right)^{1/2}$$

which is a square-root compression law.

$$\text{In expand, } V_{out} = Z_3 I_{DG} = \frac{Z_3 V_{in(av)} V_{in}}{70\mu A \times R_1 R_2}$$

$$\text{or } V_{out(av)} = \frac{Z_3 V_{in}^2 (av)}{70\mu A \times R_1 R_2}$$

which is square-law expansion.

★ ★ ★

IN THE EXPAND MODE the output noise of the NE570 is about 20μV and the maximum signal output available is around 5V r.m.s. (2V r.m.s. in compress). Thus the available dynamic range of this chip is in excess of 105dB. To take maximum advantage of this very good figure an input amplifier stage in the form of an LM381 low-noise chip is used to drive the NE570 at fairly high levels on playback see Fig. 4. Resistors R_4 and R_3 bias the output voltage to about half supply voltage. The configuration chosen also allows the gain in playback and record modes to be changed very easily. The value of R_1 was chosen to suit my hi-fi set up and allows a maximum input signal level in compress mode at any frequency of 2.0V peak. And the value of R_2 was chosen to suit my tape recorder when playing back signals recorded at -10 to -6VU. In the expand mode the absolute maximum input signal is 300mV peak.

Referring to Fig. 3 the complex impedance Z_3 is realised in Fig. 4 by R_5 , R_6 and C_7 . These components provide the signal pre-emphasis as follows. At low frequencies C_7 is virtually open circuit and Z_3 is 100kΩ. As frequency

increases the reactance of C_7 decreases and gradually shunts R_5 with R_6 , until at high frequencies C_7 is virtually a short circuit. The h.f. impedance of Z_3 is then $33k\Omega$ in parallel with $100k\Omega$ ($25k\Omega$) i.e. 12dB lower than the low frequency impedance. Hence the 12dB pre-emphasis prior to compression and 12dB de-emphasis after expansion. The value of Z_3 was chosen so that the average gain of the NE570 at the signal levels involved was approximately unity. Thus on switching the noise reduction system in and out there is little or no difference in output level.

The NE570 is d.c. biased with R_7 and R_8 with a.c. feedback being returned to ground by C_8 .

Input offset currents in the variable-gain cell can cause even-harmonic distortion which can be trimmed out if desired; it is quoted as typically 0.3% if pins 8, 9 of IC_2 are left unconnected. Provision is made on the p.c.b. for R_9 , R_{10} and the pre-set resistor which can be included to trim the distortion down to 0.05%, given a distortion meter to set up this adjustment.

Capacitor C_{10} is the rectifier averaging capacitor and its value determines the transient response of the compander. The value of $3.2\mu F$ was

determined by experiment only and was found to suit the type of music which I most often listen to (pop with some lighter classics). You may of course, choose other values to suit your own preferences.

Resistors R_{12} and R_{13} are included to refer the a.c. signals to ground so that on switching between in and out, or between compress and expand, large d.c. changes are not passed on to the output resulting in loud "thumps".

The rectifier bandpass filter and pre-emphasis are realised by IC_3 , a quad op-amp, also a fairly conventional voltage-controlled voltage source type of active filter. Resistors R_{24} , R_{25} and R_{18} bias the filter output voltage to half supply voltage.

Components R_{21} , R_{22} and C_{16} provide rectifier pre-emphasis. At low frequencies C_{16} is open-circuit and the closed-loop gain of $IC_3b(d)$ would be $R_{23}/(10+100)k\Omega$. At high frequencies C_{16} is short-circuited and the gain is $R_{23}/10k\Omega$, i.e. 20dB higher.

Signal pre-emphasis at low frequencies is produced by C_{11} in conjunction with R_{11} and the internal $20k\Omega$ resistor. Resistor R_{26} limits the maximum l.f. pre-emphasis to 12dB. In compress, this network controls the feedback current

via the ΔG cell and in expand the network controls the input current to the NE570 op-amp. Components R_{11} , C_{11} , R_{26} provide l.f. pre-emphasis in the compress mode and l.f. de-emphasis in the expand mode. If you find that hum pumping is still a problem experiment with different values of C_{11} and R_{26} , according to how much hum is present in the tape recorder playback output.

The lowish value of C_9 , in conjunction with the low values of R_{14} , R_{15} forms a high pass filter (f_0 20Hz) to remove the change in direct voltage which occurs at the NE570 output pins when the gain changes. This does not affect the l.f. signal frequency response however, because C_9 is within the feedback loop around the NE570.

I chose to use flat p.c.-mounting NF-type relays by Thorn or National Panasonic to achieve signal switching between compress and expand mode and to switch the processor in and out of circuit. Multipole switches, other types of relay or even semiconductor switching may be used, but the p.c.b. design accepts only the NF relays, however. It is advisable to use separate power supply and earth return leads for the relays. The relay coil current is about 40mA and this will avoid small

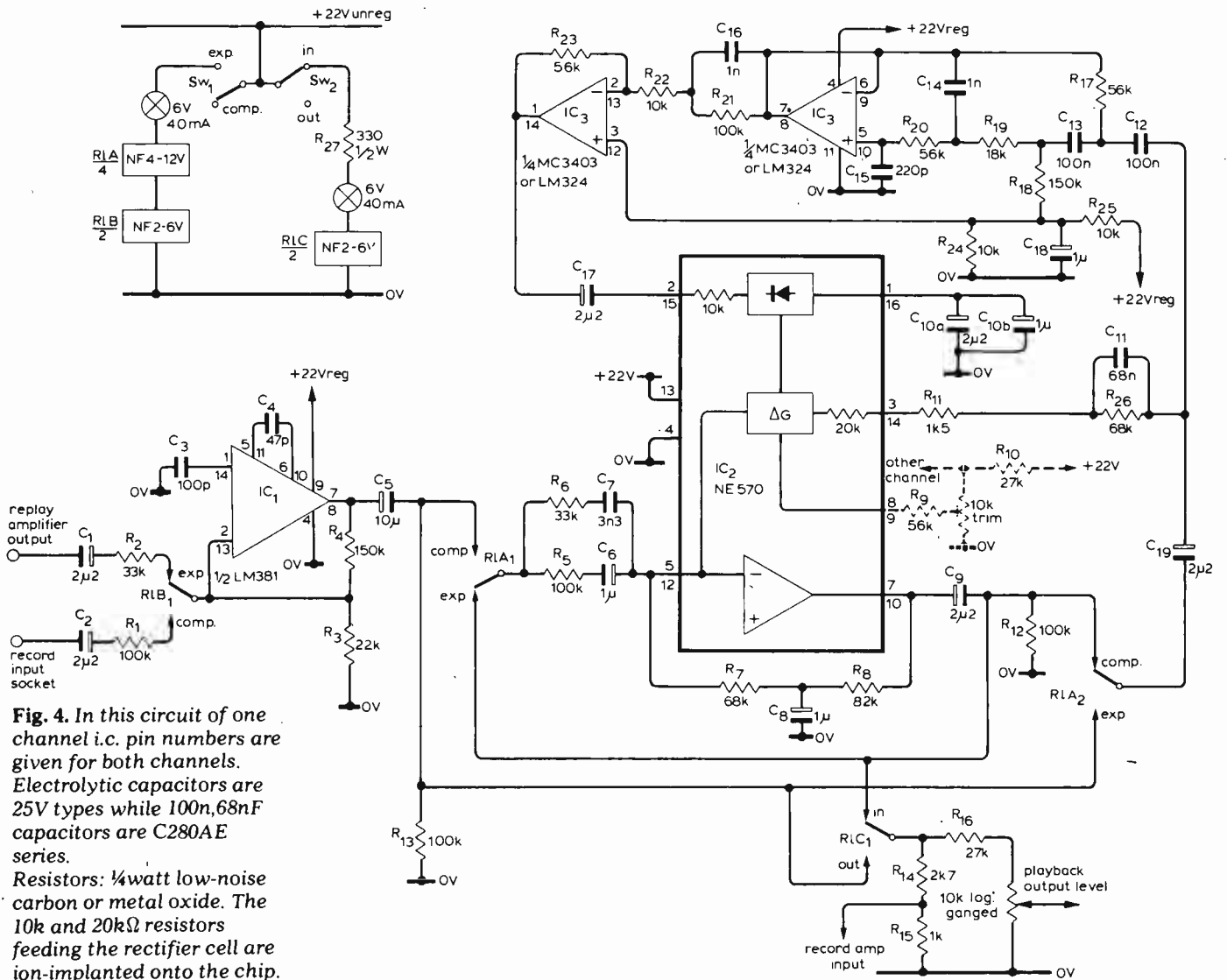
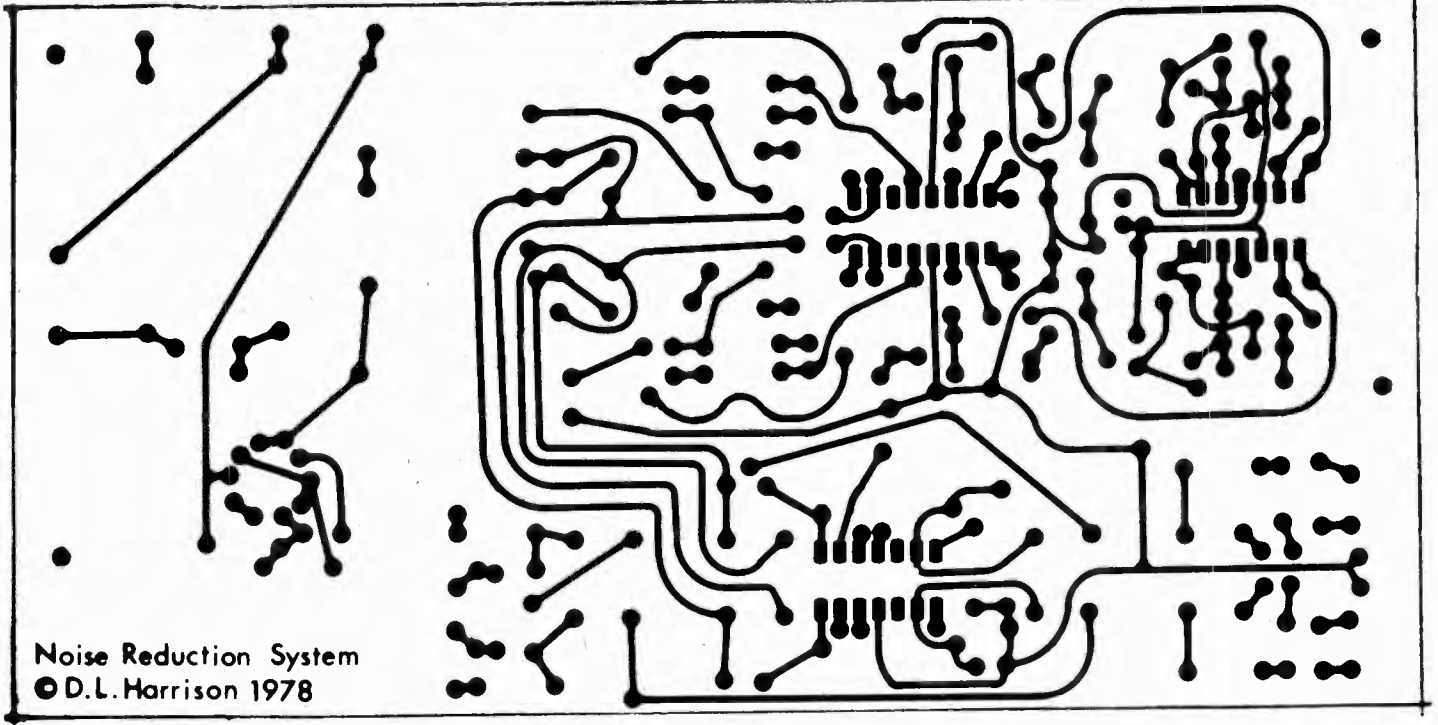
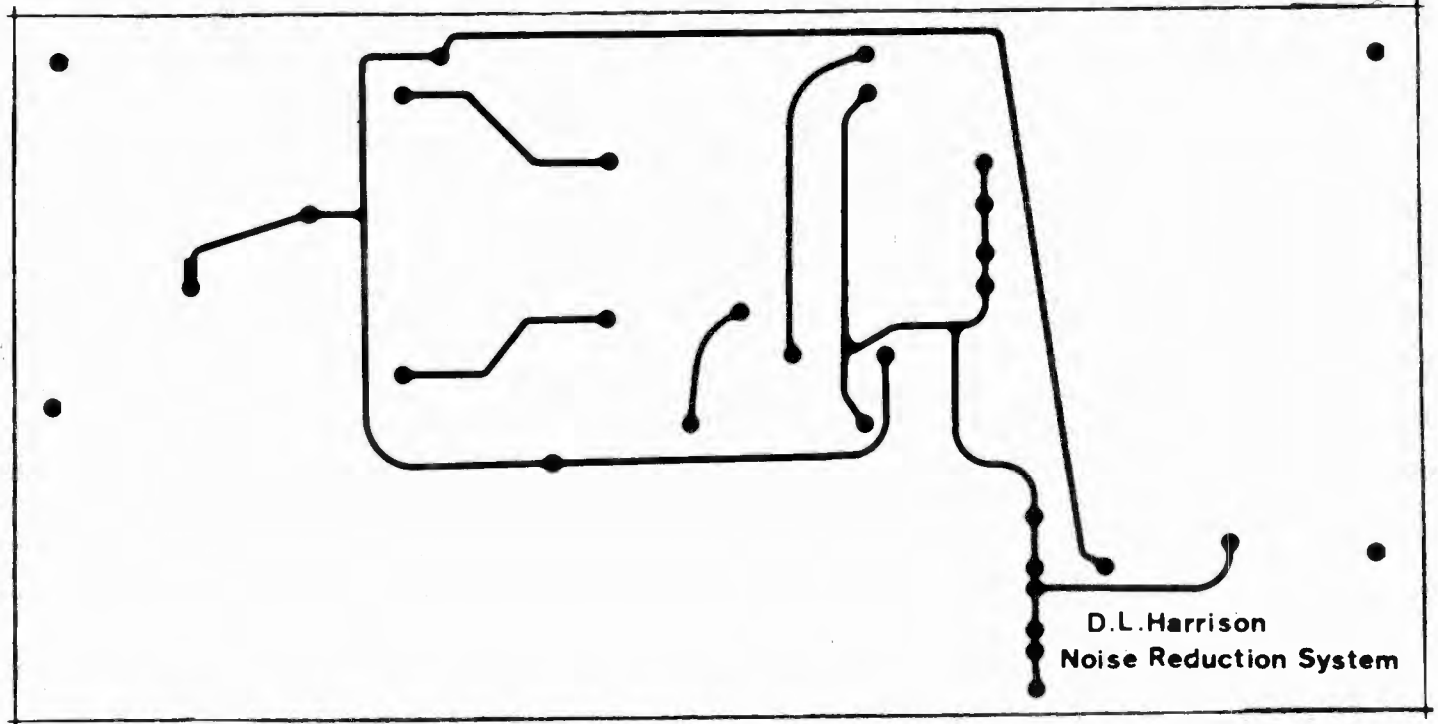

Fig. 4. In this circuit of one channel i.c. pin numbers are given for both channels. Electrolytic capacitors are 25V types while 100n, 68nF capacitors are C280AE series. Resistors: 1/4 watt low-noise carbon or metal oxide. The 10k and 20kΩ resistors feeding the rectifier cell are ion-implanted onto the chip.



Noise Reduction System
 © D.L. Harrison 1978



D.L. Harrison
 Noise Reduction System

Double-sided glass fibre printed boards are available from the author at 22 Chandos Drive, Martlesham, Woodbridge, Suffolk IP12 4TA at £3.50 inclusive. NE570 i.c. costs £4.95 from the same source.

Board holes are 0.8mm dia. except mounting holes (3.5mm), potentiometer holes (1.3mm), and relay, terminal connections and power supply components (1mm).

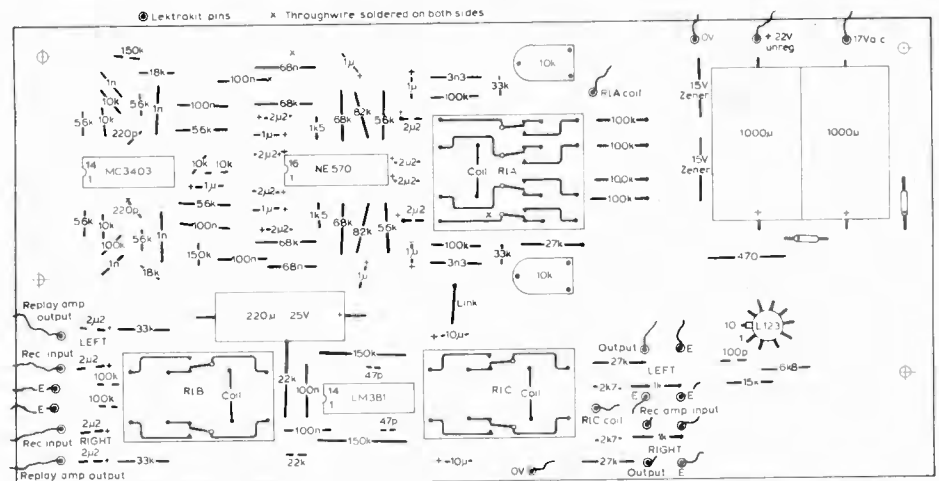

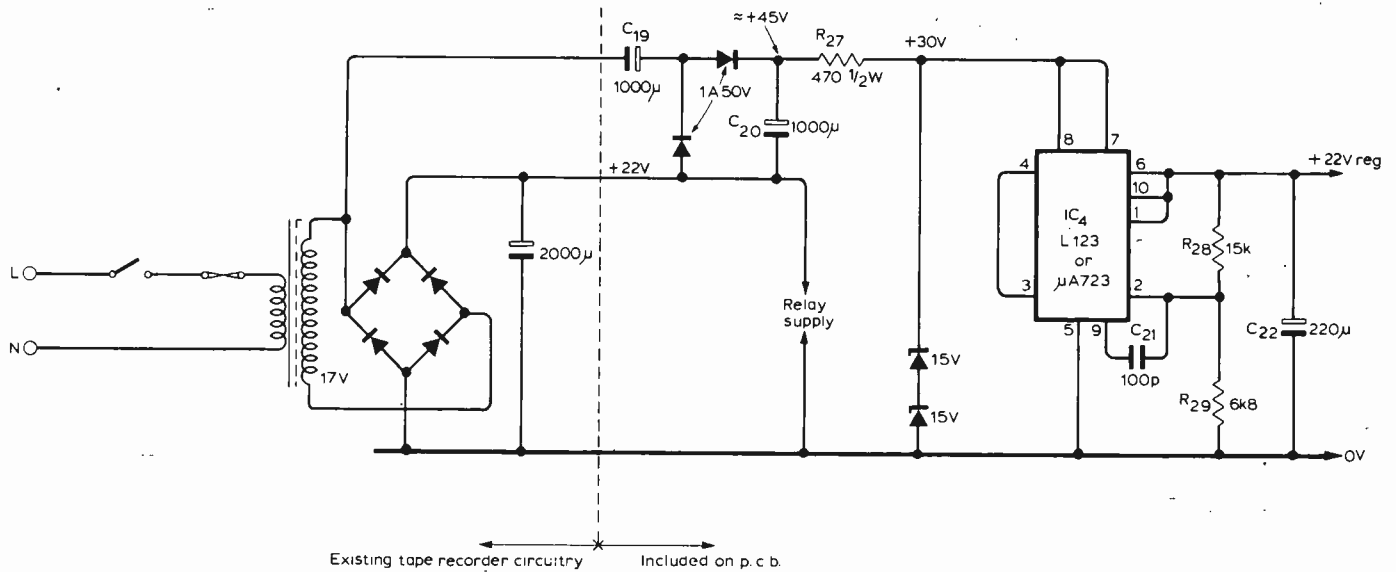

Fig. 5. Printed board design includes the power supply components to the right of the broken line of this suggested circuit.

clicks being heard due to transient voltage drops in the signal earth line.

A possible power supply circuit is shown in Fig. 5. As my system was to be built into an existing tape recorder I used its existing mains transformer and rectifier. The transformer secondary provided about 17V r.m.s. on load and could easily cope with the extra loading. The circuit consumes about 20mA, the relays up to 80mA and the voltage regulator another 5mA. The rectified output voltage on the reservoir capacitor of the tape recorder was about 22V d.c. on load. A voltage doubler circuit was used to obtain a voltage of about +45V. The voltage applied to the LM123 voltage regulator i.c. is dropped by R₂₇ and limited under no-load conditions by Z₁ and Z₂ to about 30V. The ratio (R₂₈ + R₂₉)/R₂₉ determines the output voltage. The p.c.b. design includes the power supply components to the right of the broken line in Fig. 5. The current through, and the voltage drop across, the LM123 are sufficiently low for there to be no need to heatsink it.

Precautions

When a music signal is compressed, regardless of whether pre-emphasis is used or not, its tonal balance is dramatically changed. This is because higher frequency components of the signal for example cymbals, wire brush, etc., in general contain less energy than the low or mid-range frequencies. Because of their lower amplitude, when passed through a compressor they will be amplified more, relative to the lower frequency instruments, when there are no other high level signals present. This is confirmed by listening to a compressed music signal, even without pre-emphasis, when it sounds extremely bright and tippy. When recording a compressed signal, therefore, the problem of h.f. tape saturation is made even worse because there is now a greater proportion of high frequencies to deal

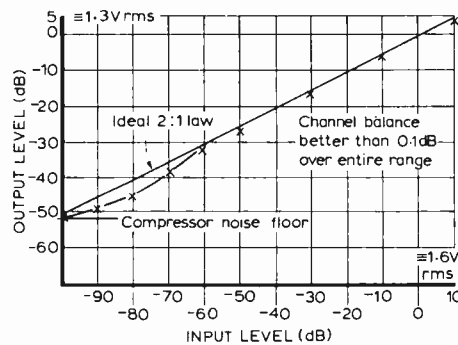

Compressor law with ideal curve and measured values. Measurements made at LM381 input and NE570 output at 1kHz.

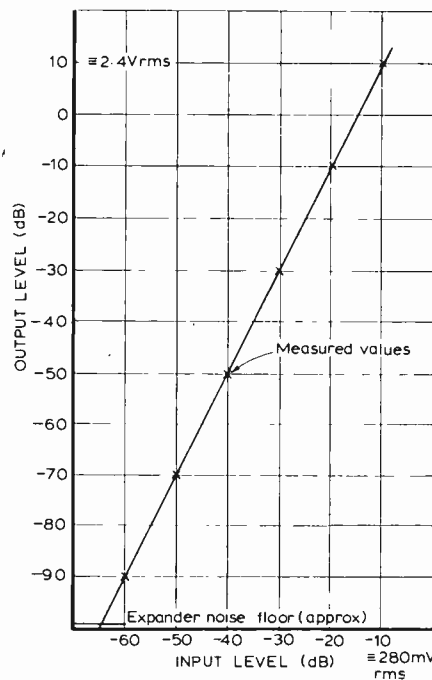

Expander characteristic with ideal square law curve and 1kHz measured values (marked x).

with. This has the effect of making the waveform even more peaky in nature. If the tape recorder VU meters are of the simple averaging type instead of peak-responding then recording at levels which cause the VU meters to peak at 0VU may well cause h.f. clipping. This causes high frequency instruments to sound rather like two sheets of glasspaper being rubbed together! I found it necessary to record at levels not exceeding -6VU. This is no disadvantage because the noise reduction obtained is sufficient to ensure that tape noise is still inaudible, even when recording at these lower levels. Indeed the frequency response will almost certainly improve by recording at lower than normal levels. Determine the optimum record level and adjust R₂ to alter the gain of the LM381 stage. This compensates for lower or higher output voltages from the tape playback amplifier. □

Come and see us at "Breadboard '78"

Wireless World will be taking part in "Breadboard '78", an exhibition of electronic "kits and bits" to be held at Seymour Hall, Seymour Place, London W1, November 21-25, from 10 a.m. to 7 p.m. each day. Admission price is £1.00 (students 70p). Readers will be welcome at our stand, No. B4.

Breadboard survey - p.91