

PE Sound Synthesiser 6

TONE CONTROL & EXPERIMENTAL SOUND STUDIO

By G.D. Shaw



THIS month the Tone Control module will be described together with some notes on the setting up of an experimental sound studio.

HUTCHINSON TONE CONTROL

The tone control circuit used in the Synthesiser is based upon the design by P. B. Hutchinson which appeared in *Wireless World* (November 1970) and which, in turn, was inspired by R. Ambler's design for a "Tone Balance Control" which was published in the March 1970 issue of the same journal. A number of minor changes have been made to the original circuit in order to make it fully compatible with the circuitry in the Synthesiser but the frequency selective network, suggested by Hutchinson have been retained.

The type of tone control usually adopted for the majority of domestic equipments is that in which the greatest effect occurs at the extreme ends of the audio frequency spectrum while the mid-band frequencies remain relatively unchanged. The Baxandall and Siemens designs provide just such a characteristic. In recent years however there has been a tendency towards extending the scope of the tone controls in domestic equipment.

For purely domestic purposes there is no doubt that the ability to manipulate the frequencies over the whole of the audio frequency spectrum can make an enormous difference to the quality and effect of the ensuing sound. The Hutchinson tone control circuit combines many of the advantages of mid-band correction with relatively severe "end of range" effects all of which are extremely useful to the experimenter in sound.

TONE CONTROL RESPONSE CURVES

Fig. 6.1 shows a graphical representation (shown dashed) of the kind of effect obtainable by means of a conventional tone control circuit of the passive kind. Note that there is very little effect on the mid-range frequencies even when the treble and bass controls are adjusted to their maximum value positions.

On the other hand, the designed response of the Hutchinson circuit (shown solid) provides an overlap of bass and treble responses ranging from about 200Hz to 4kHz. The provision of separate boost and cut controls to both the bass and treble ranges therefore means that it is possible to tailor the overall characteristic of the curve to suit many particular applications. It is, for

example, possible to build up tonal correction curves to compensate for deficiencies in sound transmission transducers such as pick-ups or loudspeakers.

The basic principle of operation is illustrated graphically in Figs. 6.2 and 6.3. Each potentiometer in the circuit controls the 3dB frequency of a curve having a slope of about 6-7dB/octave, the function of the potentiometers being in accordance with the direction of the slope. In Fig. 6.2 the dashed lines (1) represent the effect on the audio frequencies when all the controls are set flat. Since both the boost and cut selective networks are designed to have a fairly close match a similar result is obtained if all controls are set to their maximum positions.

With all the controls set flat, the effect of advancing any one of them is to bring the related slope further into the audio spectrum. The dotted line (2) shows the result of advancing the treble boost control about halfway. So far, of course, the resultant curve is similar to that obtainable from a conventional tone control circuit but if the treble cut control is now advanced from its flat position the effect is to reduce the

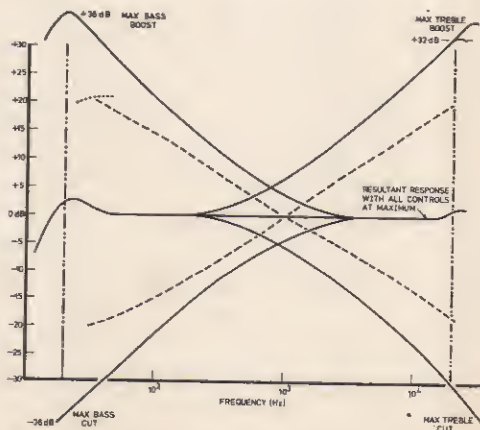

Fig. 6.1. A comparison of characteristic curves obtained from a conventional passive tone control (shown dashed) and those from the Hutchinson circuit (shown solid)

degree of boost to the upper frequencies without affecting the boost applied to the middle frequencies. This is shown as the overall resultant (4) by means of the solid line in Fig. 6.2.

An advantage of this form of control lies in the possibility of combining the effect of boost and cut settings from opposite ends of the spectrum to provide a resultant slope of up to 12-14dB/octave. A typical curve obtainable from such combination is shown in Fig. 6.3.

tone control basics

The general form of the tone control circuit is shown schematically in Fig. 6.4, from which it will be seen that two frequency selective networks are employed. One lies directly in the signal path to the operational amplifier and acts as the cut network whilst the second lies in the amplifier feedback loop and acts as the boost network.

The design of each network is identical and is shown in Fig. 6.5. C1, R1 and VR1 form a simple first-order high pass filter with a slope of about -6dB/octave. The 3dB frequency is given by $1/CR$ where C is the value of C1 and R is the value of R1 in series with the value of VR1. With the component values shown the highest 3dB frequency is thus 1.54kHz and the lowest is 28Hz. C2, R2 and VR2 form a simple first-order low pass filter again with a slope of about -6dB/octave. In this case the highest 3dB frequency is 22.6kHz and the lowest is 415Hz.

The same network is able to provide boost characteristics since, in the feedback path of the operational amplifier, it reduces the a.c. feedback thereby increasing the gain of the amplifier.

Depending upon the settings of the potentiometers the input impedance of the frequency selective networks can vary between 470 ohms in parallel with 470 ohms at minimum and 25.5 kilohms in parallel with 25.2 kilohms at maximum. It is thus necessary to provide a driving source having an output impedance of less than 200 ohms.

Similarly, it is necessary to compensate for changes in output impedance of the tone control circuit by driving into a load of 50 kilohms or more.

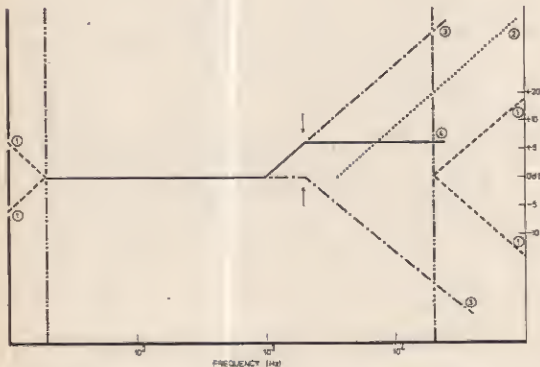

Fig. 6.2. Operation of the Hutchinson Tone Control circuit. Controls set flat ①, treble boost advanced—other controls flat ②, projected treble boost and cut with controls adjusted separately ③, resultant curve resulting from summing the boost and cut curves ④

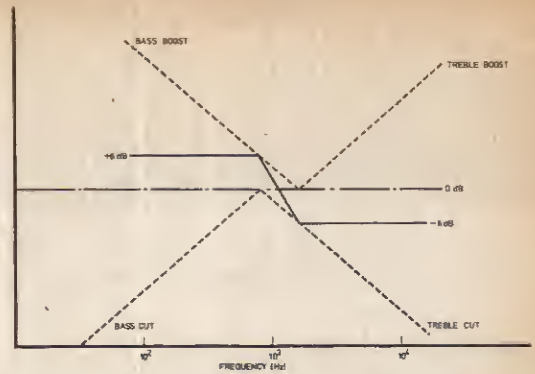

Fig. 6.3. Combining controls to give a 12dB/octave cut-off at mid-band. Dashed curves indicate responses when controls are used separately

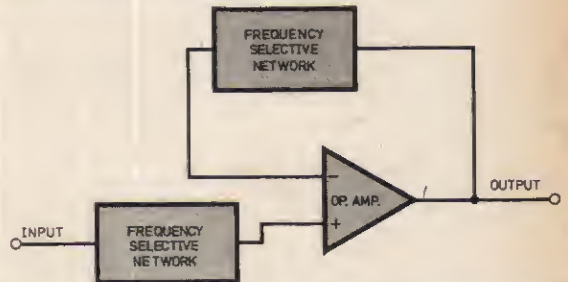

Fig. 6.4. Block diagram of Hutchinson Tone Control

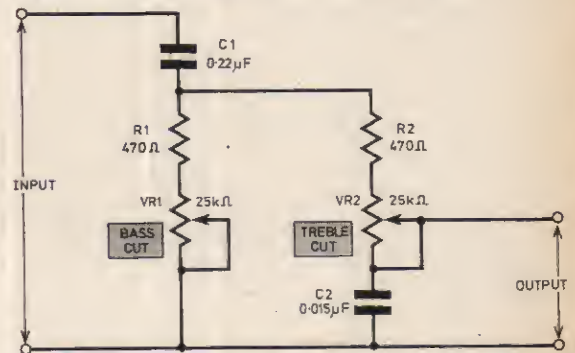

Fig. 6.5. Configuration of high pass and low pass filters used in Hutchinson Tone Control

THE COMPLETE CIRCUIT

The complete circuit of the Tone Control is shown in Fig. 6.6. TR1 is an emitter follower which provides a low impedance drive. R10 and R11 provide d.c. feedback to maintain the output of the amplifier at 0 V. Capacitor C6 decouples audio frequencies from the d.c. feedback loop and R12 provides a limit to this decoupling so that the a.c. closed-loop gain of the amplifier is limited to about +36dB. In the original circuit this was found necessary to avoid resonances at the extreme ends of the audio spectrum under conditions of maximum boost. The resonances were caused by interaction between the boost characteristic and the d.c. feedback loop at the bass end, and the high frequency compensation of the amplifier at the treble end.

TONE CONTROL MODULE

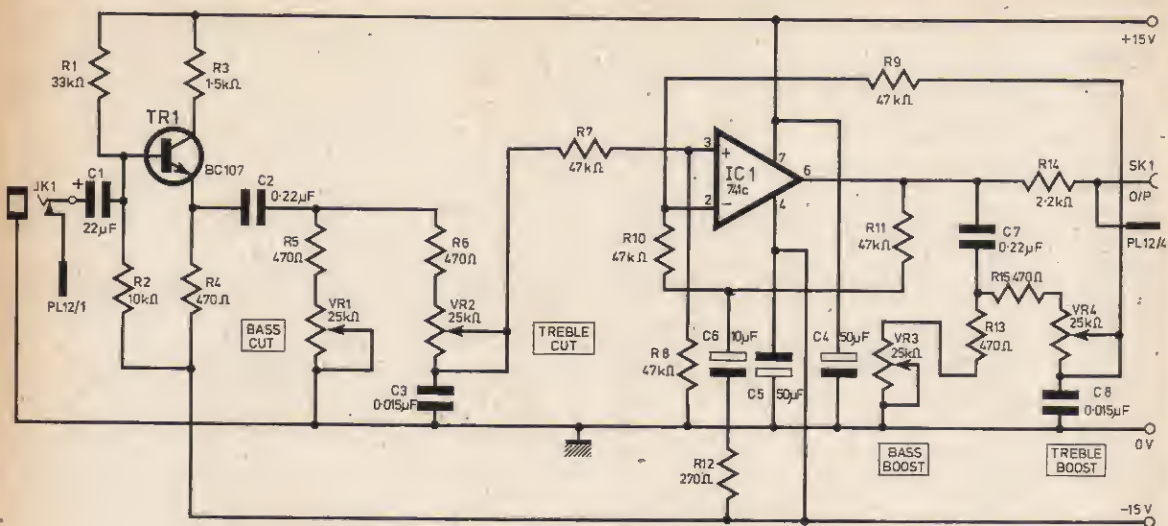

Fig. 6.6. Circuit diagram of the tone control

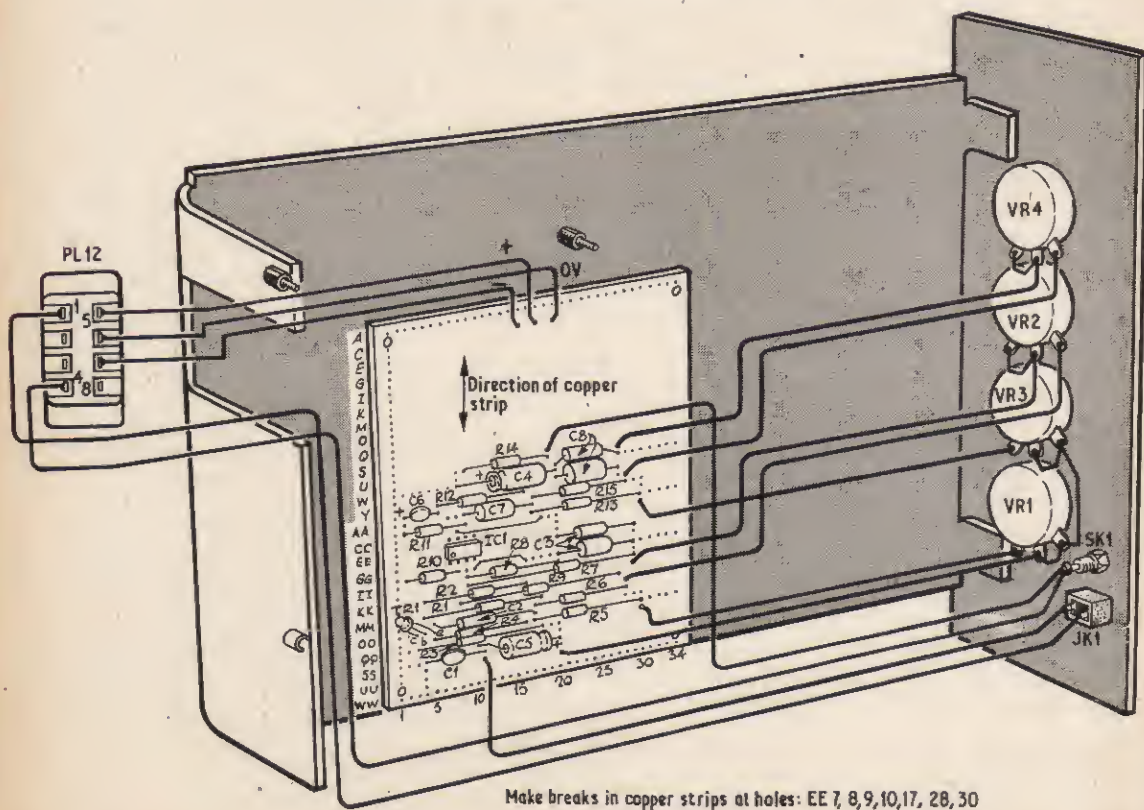

Fig. 6.7. Veroboard component assembly and wiring details for Tone Control module

The original circuit utilised a 709 operational amplifier as the active element and substitution of a 741 has resulted in the virtual elimination of high frequency resonance problems. However there is the possibility that low frequency resonance may remain under conditions of maximum bass boost although this can be tuned out by careful adjustment of the value of R12.

ASSEMBLY

Construction of the module should generally follow the pattern already outlined, that is, assembly and wiring of the front panel components followed by assembly of the module hardware and finally the wiring in of the circuit board.

Layout of the components on the circuit board is not too critical and the recommended circuit board layout is shown in Fig. 6.7.

Some care should be taken in wiring up the potentiometers since it is quite easy to wire these in the wrong way round and this will give rise to some very odd results during testing out the finished module. Fig. 6.7 also shows the component layout and wiring on the front panel and McMurdo plug.

TESTING

Testing the module covers only the establishment of performance characteristics at various points in the audio spectrum and it is recommended that a sine wave oscillator be used for this purpose. Starting with the oscillator at 20Hz the frequency should be advanced in multiples of 20Hz up, to and including 100Hz and thereafter in multiples of 200Hz up to 1,000Hz.

From 1,000Hz the frequency advance should be in steps of 2,000Hz. This procedure will give about 20 points on the graph and should be quite sufficient to establish the circuit characteristics.

The measuring procedure should be repeated five times, the first being with all controls set flat and subsequent measurements with each of the individual boost and cut controls set to maximum in turn. If component values have been chosen as specified the resultant graph should bear a very close resemblance to that shown in Fig. 6.1.

There is little to be said concerning the actual usage of the module since, as with all tone control circuits, the position of the various controls will be dictated by a variety of circumstances not least of which is the individual constructor's preference. The little extra trouble involved in the manipulation of four controls is well rewarded by the greater versatility of the system in the provision of exactly the sound required. As a general guide to module usage there are two basic methods of operation.

Tonal correction curves are provided by setting both the boost and cut slopes to the middle of the audio spectrum and then moving one or the other out until the required effect has been achieved.

Simple boost or cut characteristics are obtained by setting all the slopes to the extreme ends of the audio spectrum and then moving the appropriate one in towards the middle until the desired effect is achieved. If only one control is manipulated in this latter case the resultant slope will, of course, be about 6dB/octave.

FORMING A STUDIO

In part four of this series the reader was introduced to the idea that the tape recorder was a very necessary adjunct to the Synthesiser if the full potential of the instrument were to be realised. This idea may be extended by considering the Synthesiser as the central focus around which may be constructed a simple yet versatile sound studio capable of providing a wide range of facilities to the keen experimenter. Thus, in addition to the tape recorder, there are a number of other items of so-called peripheral equipment which may be added to and usefully extend the versatility of the system. Fig. 6.8 illustrates one possible arrangement which utilises a fairly wide range of external apparatus.

In common with the basic concept of modular construction for the Synthesiser, the establishment of a studio may also be considered on the basis of a form of modular growth in which individual pieces of apparatus, including the Synthesiser, are treated as separate modules. In the Synthesiser itself all the modules plug into a bus-bar system which provides power supplies and signal paths for the interconnected, prewired modules. In a similar fashion the studio must have a central signal routing system and this is provided by what is known as the main patch. The power supplies for the studio apparatus are not, however, routed via the main patch, and the provision of a power supply distribution system will be dealt with later in these notes.

THE MAIN PATCH

The main patch in any studio is thus a very important piece of apparatus. Ideally it should provide a rapid means of interconnecting the signal pathways of all the apparatus incorporated in the studio in virtually every possible configuration and do so with a minimum of noise and crosstalk addition.

There are a number of possibilities for the construction of the main patch, the actual method adopted depending largely upon the means and inclination of individual constructors. It is worthwhile stressing,

COMPONENTS . . .

tone control

Resistors

R1	33k Ω	R7-R11	47k Ω (5 off)
R2	10k Ω	R12	270 Ω
R3	1.5k Ω	R13	470 Ω
R4	470 Ω	R14	2.2k Ω
R5-R6	470 Ω (2 off)	R15	470 Ω

All 2% $\frac{1}{2}$ watt metal oxide

Capacitors

C1	22 μ F tantalum 16V
C2	0.22 μ F polyester
C3	0.015 μ F polystyrene
C4-C5	50 μ F elect. 25V (2 off)
C6	10 μ F elect. 25V
C7	0.22 μ F polyester
C8	0.015 μ F polystyrene

Integrated Circuit

IC1 741C 8pin d.i.l.

Transistor

TR1 BC107

Potentiometers

VR1-VR4 25k Ω linear min. moulded carbon (4 off)

Miscellaneous

JK1-3.5 mm jack socket, SK1-2 mm miniature socket, 0.1 matrix Veroboard

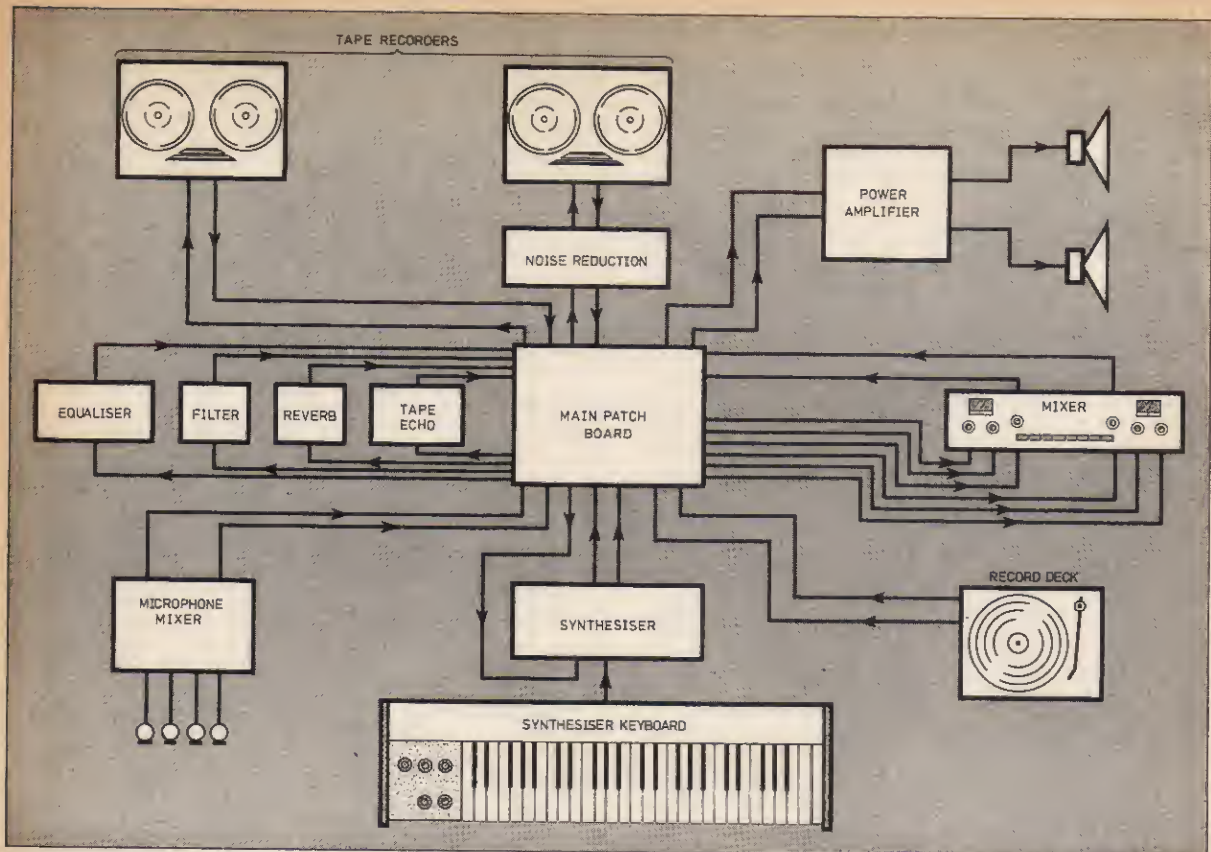

Fig. 6.8. One possible arrangement of apparatus to form an experimental sound studio

however, that a little extra quality in components chosen and effort expended in construction will be amply repaid in terms of reduction in the problems associated with poor contact assemblies.

One method of construction involving very little effort on the part of the constructor lies in the employment of ready-built patching matrices such as those manufactured by Sealectro Ltd. Matrices of a similar type are supplied "built-in" in a number of commercially available synthesisers and have proved to be quite

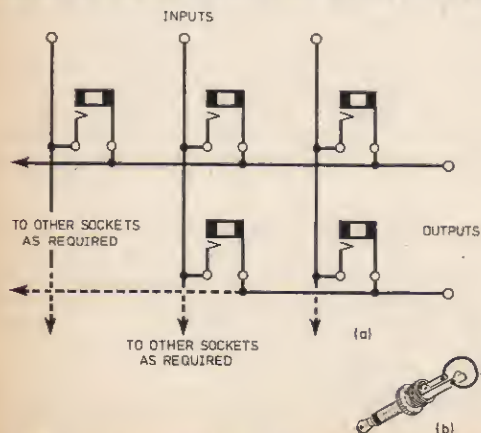

Fig. 6.9. Arrangement of jack sockets to form a patch board

successful in this application. The adoption of a ready-built matrix has the advantage that the patch can be assembled very quickly. In addition, the space taken by the patch is very small indeed although this could perhaps be something of a disadvantage if the screened signal cables for connection to the matrix are of any size at all. Another idea for the construction of a patching system is the use of 3.5mm jack sockets arranged generally as shown in Fig. 6.9. It is important to note that the type of jack sockets employed should be of the open-circuit variety.

The type of main patch employed in professional circles frequently makes use of a system based upon standard G.P.O. type jacks. Although rather larger than either of the other possibilities mentioned the greater contact area and general robustness of the components involved makes this latter system worthy of consideration if any serious work of high quality is envisaged. In terms of cost the system is not significantly more expensive than those previously mentioned.

OVERCOMING HUM

Perhaps one of the greatest problems associated with the interconnection of a range of apparatus lies in the formation of ground or hum loops within the system. In some circumstances the source of the hum can be quite difficult to trace and it is therefore worthwhile expending a little time in establishing a system which eliminates, from the outset, as many sources of hum as possible.

By far the greatest source of hum lies in the formation of loops through the earthing system of mains powered apparatus. The frequency of the hum can vary between 50Hz and 120Hz depending upon the mains frequency and type of rectification employed. Until quite recently the majority of mains powered apparatus employed the live chassis method of construction in which the signal ground was common with the mains earth. This type of apparatus provides the greatest hazard as far as the formation of hum loops is concerned.

COMMON POINT EARTH

Connection of a number of pieces of mains powered apparatus into the main patch may be accomplished as shown schematically in Fig. 6.10. In this case power supplies are distributed from a panel which has one common earth to the mains. Screened signal cables are used where the screen is disconnected at one end of the cable only. Thus the connections at the main patch are made on high signal levels only while the circuit is completed through the common earth in the power distribution panel.

Although these latter remarks apply particularly to apparatus in which live chassis construction has been employed, a similar form of interconnection may be employed with apparatus which has a fully floating signal ground, i.e. there is no electrical connection between the signal ground and the mains earth.

In circumstances where *all* the apparatus involved is of this latter form of construction it is necessary to provide a common ground return on all signal lines and this is best done by connecting the screens of all signal cables to a common point at the main patch. This latter point is left floating except in the case where mixed types of apparatus are being used and, in these circumstances, the signal cable screens of apparatus with floating outputs only are commoned at the main patch and this point then returned direct to mains earth.

CHOOSING THE RIGHT CABLE

A second prime source of hum lies in the type of cable used to route signals and its relationship to the

impedance of the inputs to which it is connected. It is best to choose a signal cable which is compatible with both low and high signal level inputs and thus one should steer clear of the majority of commercially available so called miniature signal cables which are prewired to a range of plugs and sockets. Unfortunately many of these, whilst perfectly suitable for the transmission of relatively high level signals into high impedance loads, are quite unsuited to low impedance networks due to the relatively high impedance and core/screen capacitance of the cable itself.

A signal cable which should prove suitable for most purposes in the studio will have a nominal impedance of about 50 ohms and a core screen capacitance of not more than 100 picofarads/metre.

CHOICE OF PERIPHERALS

Referring again to Fig. 6.8 the choice of peripherals for the Synthesiser must rest primarily with the individual, the only limiting factor being the compatibility of one unit with another. Although all the equipment shown is available commercially in several different forms a large proportion of it could be constructed at home with the aid of designs published. For example the Synthesiser Reverberation Amplifier (to be published next month) can be employed, without modification, to drive the spring line unit type HR162 available from Henry's Radio Ltd. Commercially available reverberation units include those manufactured by Eagle, Gramplan and Sansui ranging in price from about £20 to £70 and offering a variety of facilities.

The choice of mixers is legion and can range from the four channel T.T.C.-B2005 distributed by Adastra at about £4 to the four channel Unimixer by Soundex at prices from about £90. Again, however, the constructor may opt to build his own mixer from a range of published designs.

The choice of filter units is rather more restricted for domestic users but for those with about £200 to spend the Levers-Rich A501 offers full audio spectrum equalisation in seven bands.

THE TAPE RECORDER

As with the case of the mixers, the choice of tape recorder is extremely wide but can be narrowed down by application of a list of specific requirements which are desirable although not absolutely mandatory. In professional circles the production of a Synthesiser recording may entail a mix-down from perhaps as many as twenty-four discrete tracks. In these circumstances the final master tape will have been involved in only one tape to tape transfer and consequently the recorded sound is likely to have suffered only the very slightest loss in quality.

If the amateur attempts to simulate these professional methods (in terms of tracks involved) with the equipment normally available to him there may be as many as fifteen to twenty tape transfers involved in a very complex recording. Thus the quality of sound on the tapes involved in a number of transfers is likely to be much reduced in comparison with the original. This factor alone provides the first and foremost requirement of any tape recorder to be used for creative work and that is quality.

In general terms the purchaser should invest in a machine which offers the best possible specification coupled with a minimum number of features designed to ease the problems entailed in the production of good quality recordings. These may be summarised as follows.

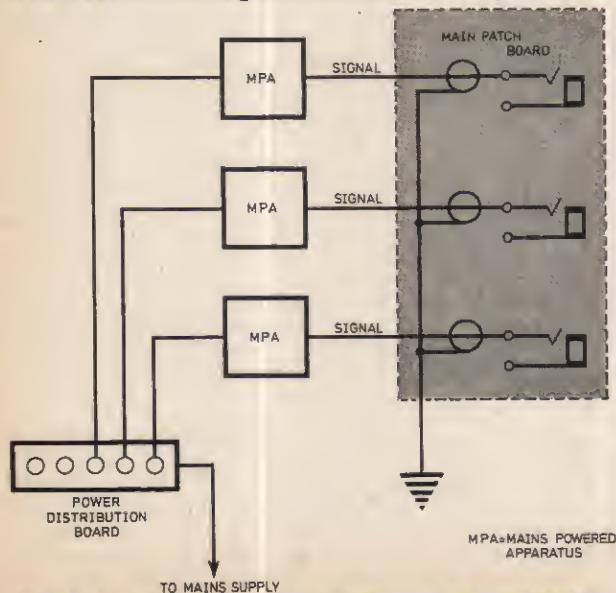

Fig. 6.10. Connections of peripherals into the main patch

SPECIFICATION AND MACHINES

Three speed machines are preferable with 38cm/sec; 19cm/sec and 9.5cm/sec providing the ideal. Speeds below 9.5cm/sec are unlikely to be very useful. Three or four heads with provision for "on" and "off" tape monitoring. Stereo quarter track machines having sound-with-sound facilities, ideally through the medium of an input mixer, provide the minimum facilities for just about the only form of multitracking available to the average amateur.

There are a number of tape recorders on the market which combine an excellent technical specification with the features listed above. Amongst these are: Akai 1720L and GX220D; Beocord 1600; Ferrograph 702 and 704; Philips N4418 and N4450; Pye 9137; Rovex Series 77 1104; Sony TC630 and TC270; Telefunken M204TS; Uher Royal de Luxe.

As far as sound-with-sound or track transfer is concerned most of the recorders listed employ slightly different methods of providing this facility involving the use of one or more switches and, in some cases, an external signal routing cable. In this respect the Philips N4450 is notable in that, after laying down the first recording, this may then be transferred back and forth between tracks, with or without the addition of further material, by the manipulation of a single switch. This latter recorder also incorporates facilities for the addition of echo/reverberation again at the throw of a switch.

DECK CONVERSION

Recorders offering the facility of more than two tracks, or four tracks if one includes the quadrasonic types that are beginning to make their appearance, would normally be expected to be priced out of the reach of most amateurs. The determined constructor, however, could do worse than consider the conversion of some of the computer decks which become available from time to time. Several of the capstan driven decks now available from about £40 are superbly engineered devices and suitable for conversion. The speed of computer decks is usually quite high but this need not necessarily be a disadvantage since it would be used for record and replay of its own material only.

Heads are available from a number of sources. Gresham, for example, manufacture an eight-track, half-inch head for record/replay purposes at a price of around £70-£80. For the purposes of erasing, economies can be made by stacking a number of stereo erase heads. The electronics for the recorder could be based on the Hi-Fi Tape Link (recently published in this magazine) or, alternatively, on the range of Motorola integrated circuits designed specifically for tape record/replay purposes.

OTHER ADDITIONS

The addition of a Dolby B noise reduction unit should be a prime consideration and for a studio system it is best to choose a discrete unit rather than have the system built-in to a recorder.

Other useful additions to the studio include a separate power amplifier with speakers for monitoring purposes and a suitable turntable unit. These latter items could generally be "borrowed" from the domestic Hi-Fi system as and when required.

Next Month: The Meter Unit; Voltage Controlled Reverberation Amplifier and Ring Modulator.

NEWS BRIEFS

Telephone Scrambler for Commercial Use

FOR businessmen who require absolute security in their communication, EMI have introduced a new electronic scrambler for use with both private and public telephone networks. Known as the Privateer it is suitable for a wide number of applications in business, commercial and industrial organisations.

Once a telephone call has been set up in the conventional manner the Privateer telephone is brought into operation simply by pressing a separate switch. Subsequent conversation is then electronically scrambled as it is transmitted to the telephone line, and only becomes intelligible when it is unscrambled by matching equipment at the receiving end.

Commercial Radio

STUDIO automation is expected to be a major feature in many of the radio stations forming Britain's new commercial network which will start broadcasting within the next 12 months. The trend is being set by London's general entertainment channel Capital Radio, which is aiming for equipment which can automatically select and play a high proportion of the station's daily programme output from material stored on magnetic tapes.

Negotiations are going ahead with EMI to supply equipment from their extensive range of Schafer radio automation systems.

Equipped with a solid-state memory, this system is able if required, to provide a full 24 hours of continuous broadcasts—the memory being programmed to select on a time or sequential basis pre-recorded "events", including entertainment, commercials, and station announcements, from its vast repertoire. Using a keyboard, an operator can insert a complete day's programme in the memory, building up the programme on a minute by minute basis if required.

Data Transmission

MANY different kinds of information, from heartbeats to motorway hazards, can now be transmitted over Britain's public telephone network in a new communications service introduced by the Post Office on June 1.

During trials, the new Datel 400 service has already been used to send heartbeat readings from a small hospital to a large one a mile away, and information on river pollution has been sent to a Government laboratory. The latest development being studied at the moment is the sending of information on motorway hazards and weather conditions to a central monitoring point.

Golden Jubilee

IN April the well-known components manufacturers, A. F. Bulgin & Co. Ltd., celebrated their 50th anniversary with an announcement of unbroken profit figures stretching back over the full 50 years to 1923 when Arthur Bulgin started the company on £100 capital.

It is perhaps indicative of the value of "service" that this organisation who hold as their aim to provide customers with a service through a family company, that they have managed to succeed so well in the face of growing and aggressive international competition.

At the celebrations Arthur Bulgin, managing director, presented three new members of the company's 25 Year Club with gold watches including Albert Ridpath, foreman of the injection moulding section, who becomes the 50th member of this club. Quite a record for a company started on £100 and still running as a family concern.