

STEREO ENHANCER

The best thing about stereo is that it sounds good! The greatest stereo hi-fi system loses its magnificence if the effect is so narrow you can't hear it. This project lets you cheat on being cheated and creates an 'enhanced stereo effect' with a small unit which attaches to your amp.

Robert Irwin

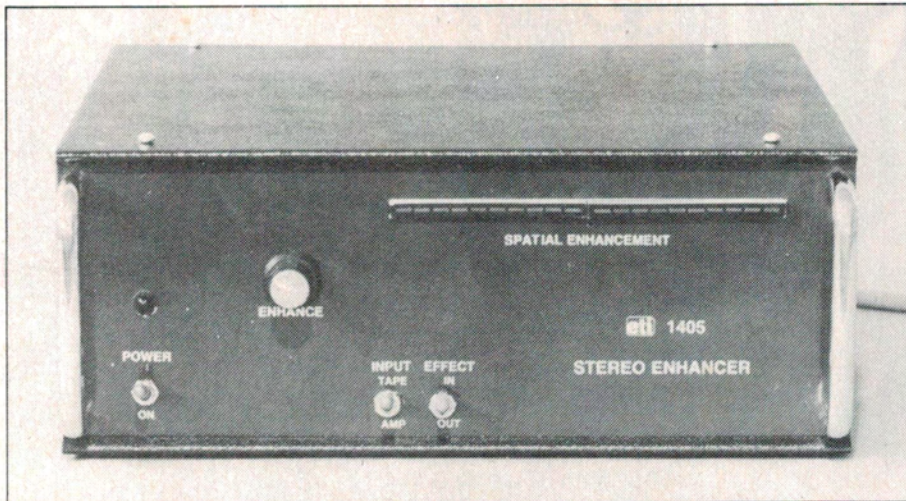

WHEN IS A STEREO not a stereo? Answer: When you try to fit your 60 cubic foot, six way monitors into your new, one bedroom flatette and find that the only place you can put them is side by side where they double as a dining table. Not the ideal situation to get that wonderful stereo separation that causes steam trains to thunder in one side of your living room, roar across the coffee table and exit through the window on the opposite side.

The ETI-1405 is designed to 'widen' out the stereo image from your amp and allow you to maintain that stereo feel even when you have to put your speakers close together.

The unit is designed to plug into the cassette input and output on the back of a standard stereo amp and can be switched in and out of circuit by using the TAPE/SOURCE switch. An alternate set of cassette in/out terminals is provided on the back of the enhancer to plug your deck into.

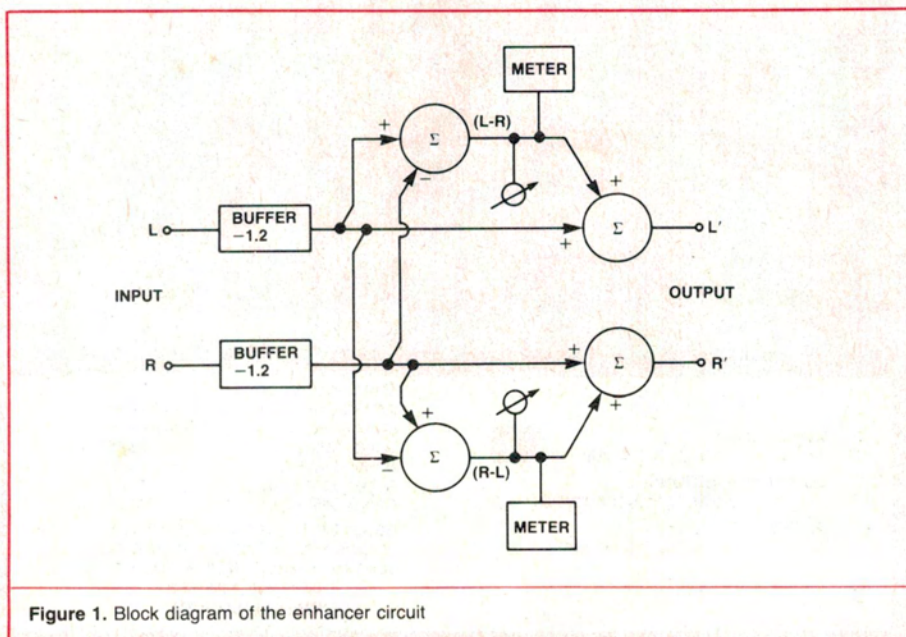

Figure 1. Block diagram of the enhancer circuit

Design details

The idea behind the circuit is very simple and has been used in small portable stereo tape decks for quite a while. Figure 1 shows a block diagram of the circuit of the enhancer. The principle used is basically to obtain the difference between the left and right channel and then to subtract this from the original left and right channel signals. This is explained more fully in the "How it Works" section.

The end result is to obtain a 'super stereo' signal which has components for the left channel of $L+A(L-R)$ and for the right channel of $R+A(R-L)$ where R is the original right channel signal, L is the original left channel signal and A is a proportion between 0 and 1 which is set by the level control.

One unusual feature of the design came about in the metering provided. It was firstly thought that a measure of the signal levels at the output, along the lines of VU metering, should be provided.

After a quick rethink though, it was decided that this wouldn't really be of much

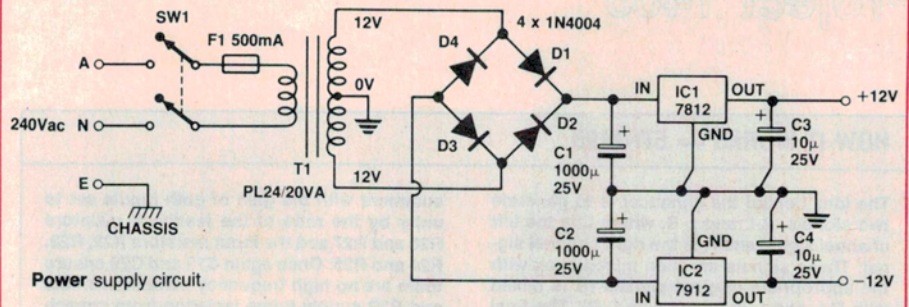

benefit to anyone as the signal levels here weren't really interesting. A much more relevant meter would be one that in some way indicated the amount of enhancement taking place. LED level meters were, therefore, placed at the output of the level control pot in the difference amp section of each channel. This gave a direct and dynamic representation of the enhancement. To add to this, the displays for each channel were mounted back to back giving a centre-zero, bar graph display which visually shows the widening of the stereo image.

Construction

It is best to begin construction with the case. The prototype was mounted in a Horwood instrument case. If you are using an

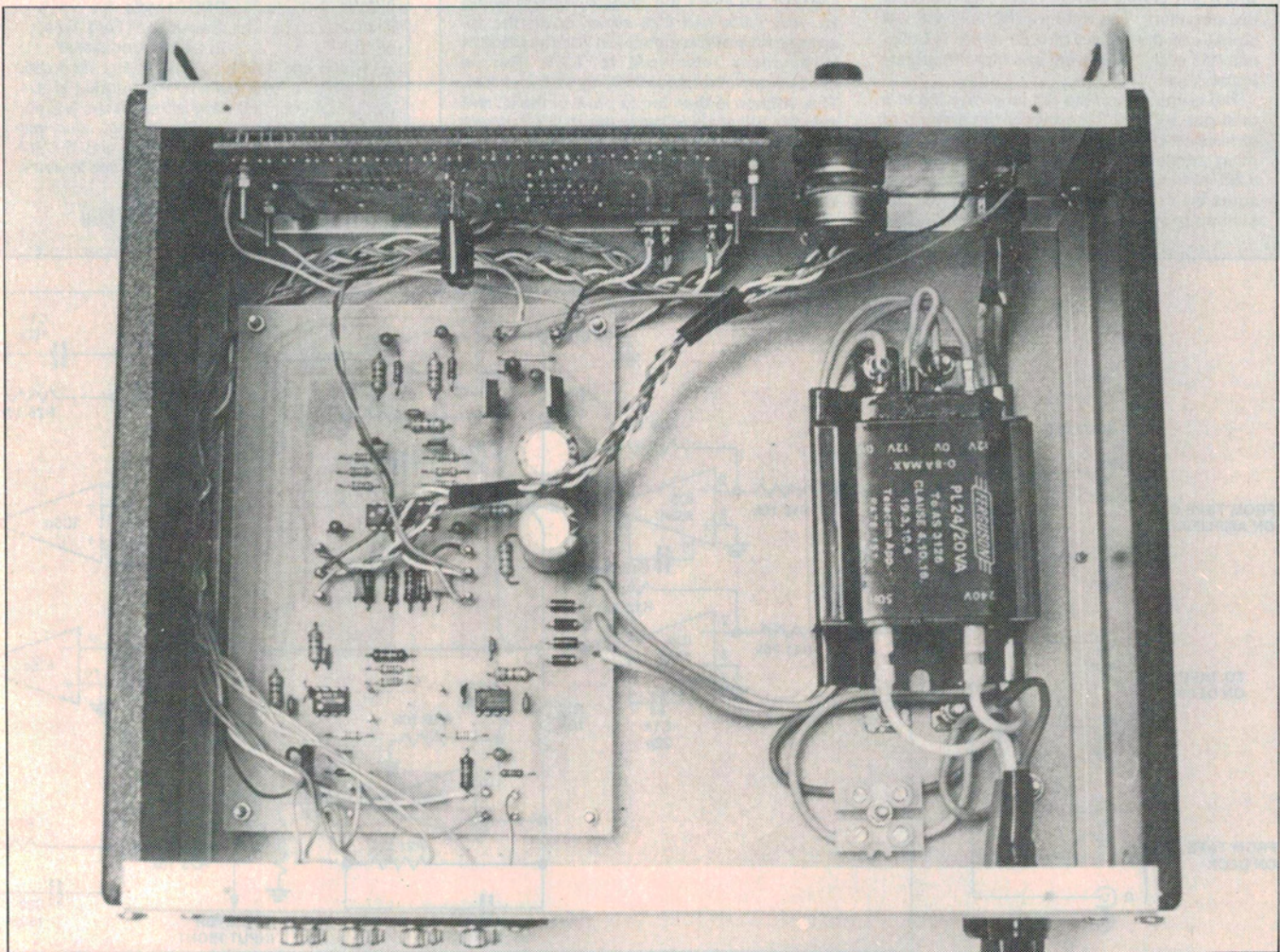
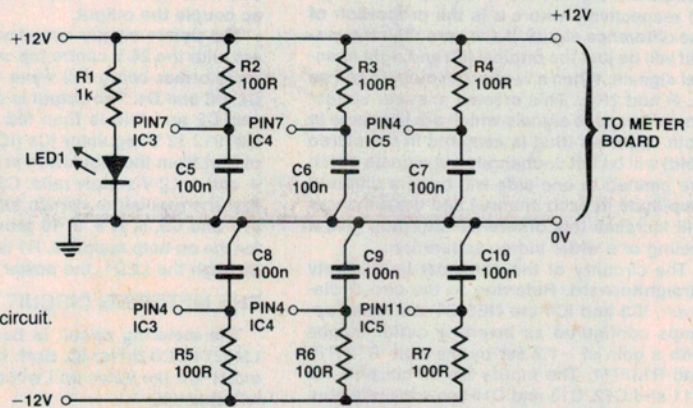

HOW IT WORKS — ETI-1405

The idea behind the enhancer is to generate two signals, R-L and L-R, where L is the left channel signal and R is the right channel signal. These signals are then mixed back with the appropriate original signals (R is mixed with R-L and L is mixed with L-R). The final composite signals are $R+a(R-L)$ and $L+a(L-R)$ respectively where a is the proportion of the difference signal. If a is zero then the output will be just the original left and right channel signals. When a is one, the outputs will be $2L-R$ and $2R-L$. This creates a 'super stereo' image because signals which are the same in both channels (that is centered in the stereo field) will be left unchanged but signals which are panned to one side will be of a different amplitude in each channel and the enhancer will increase this difference and thus give a feeling of a wider stereo separation.

The circuitry of the enhancer is relatively straightforward. Referring to the circuit diagram, IC3 and IC4 are NE5534 low noise op-amps configured as inverting buffer stages with a gain of -1.2 set by the ratio $R12/R10$ and $R13/R11$. The inputs are ac coupled via C11 and C12. C13 and C14 provide unity gain compensation for the NE5534s. The difference signals are created by IC5a and IC5b which are configured as unity gain differential amplifiers. The output of IC5a is the L-R signal and the output of IC5b is the R-L signal. C15 and C16 prevent any high frequency instabilities.

The outputs from the diff amps are fed to a dual pot, RV1, which controls the amount of difference signal being fed to the final summing amplifier stages formed by IC5c and IC5d and associated resistors. This stage sums the original and difference signals. The summing amps are virtual earth, inverting

summers with the gain of both inputs set to unity by the ratio of the feedback resistors R26 and R27 and the input resistors R22, R23, R24 and R25. Once again C19 and C20 ensure there are no high frequency instabilities. R28 and R29 supply some isolation from capacitive loading on the output and C21 and C22 ac couple the output.

The power supply circuitry is fairly standard with the 24 V centre tap secondary of the transformer being full wave rectified by D1, D2, D3 and D4. The output is smoothed by C1 and C2 and this is then fed to LM7812 and LM7912 12 V regulator ICs (IC1 and IC2). The output from the regulators provides accurate + and - 12 V supply rails. C3 and C4 ensure that the regulators remain stable. R2, 3, 4, 5, 6, 7 and C5, 6, 7, 8, 9, 10 provide decoupling for the op-amp supplies. R1 limits the current through the LED1, the power on indicator.

THE METERING CIRCUIT

The metering circuit is based around the LM3914 LED driver IC. Both the left and right meter are the same so I will only refer to the left channel.

The input to the meter is ac coupled via C24 and R32 and fed to the input pin (5) of the LM3914. D5 limits the reverse voltage swing to -0.6 volts and C26 slows down the response time of the meter. Pin 7 of the LM3914 is internally referenced to 1.2 V. This is divided down to about 0.2 V by R36 and R34. This voltage is then fed to pin 6 of the IC and sets the full scale of the meter to 0.2 V. If less sensitivity is required then R34 can be increased. The sum of R34 and R36 should be kept to less than about 1 K otherwise the brightness of the display may decrease.

PARTS LIST — ETI-1405

Resistorsall 1/4 W, 5%	
R1.....	1k
R2, 3, 4, 5, 6, 7,	28, 29, 34, 35.....
	100R
R8, 9, 30, 31,	32, 33.....
	100k
R10, 11, 14, 15,	16, 17, 18, 19,
	20, 21, 22, 23,
	24, 25, 26, 27.....
	10k
R12, 13.....	12k
R36, 37.....	560R
RV1.....	100k lin. dual ganged
Capacitors	
C1, 2.....	1000µ 25 V RB electro.
C3, 4, 11, 12,	17, 18, 21, 22,
	24, 25.....
	10µ 25 V electro.
C5, 6, 7, 8, 9,	10.....
	100n ceramic bypass
C13, 14.....	22p ceramic
C15, 16, 19, 20.....	150p ceramic
C23, 28.....	2µ 25 V RB electro.
C26, 27.....	220n greencap
Semiconductors	
IC1.....	LM7812 pos. regulator
IC2.....	LM7912 neg. regulator
IC3, IC4.....	NE5534 op-amp
IC5.....	TL074 quad op-amp
IC6, IC7.....	LM3914 LED driver
D1, 2, 3, 4.....	1N4004 rectifier diodes
D5, 6.....	1N914 small signal diode
LED1.....	5mm red LED
	two 10 LED arrays
Miscellaneous	
SW1, 2, 3.....	DPDT toggle
T1.....	Transformer Ferg. type
	PL24/20VA or similar

ETI-1405 and 1405b pc boards; Horwood case type 84/10/V; two four way RCA socket arrays; Scotchcal front and back labels; mains flex and plug; mains grommet and clamp; four way terminal block; 2AG fuse holder and 500 mA fuse; hookup wire; nuts and bolts; knob for rotary pot; four rubber feet.

Price estimate: \$70-\$80

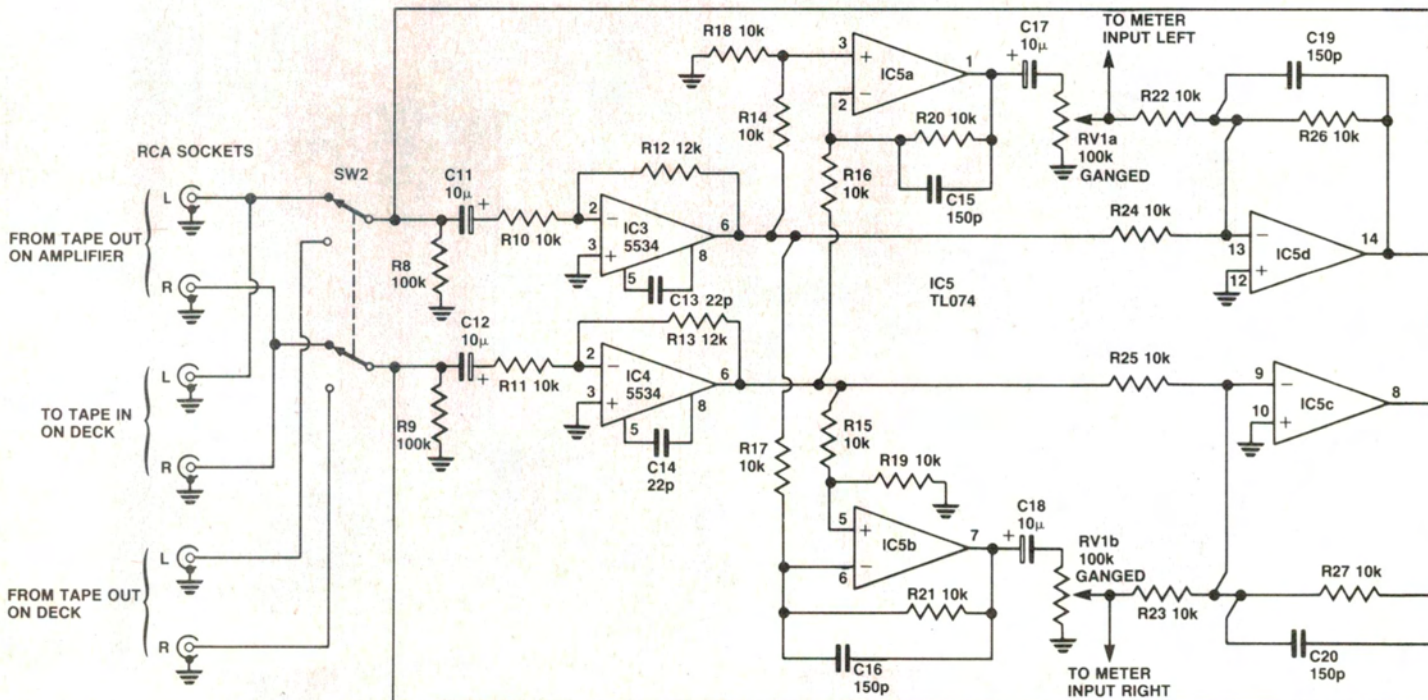

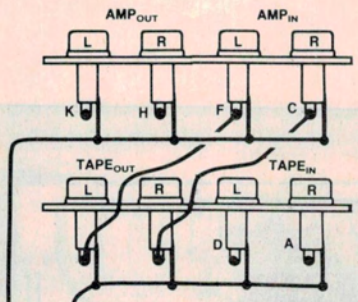
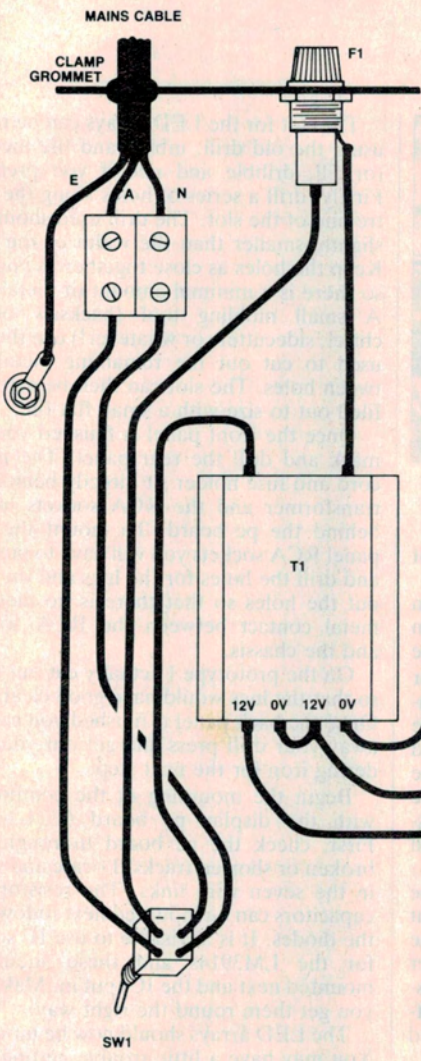

For a guide to buying components and kits see **SHOP AROUND** this issue.

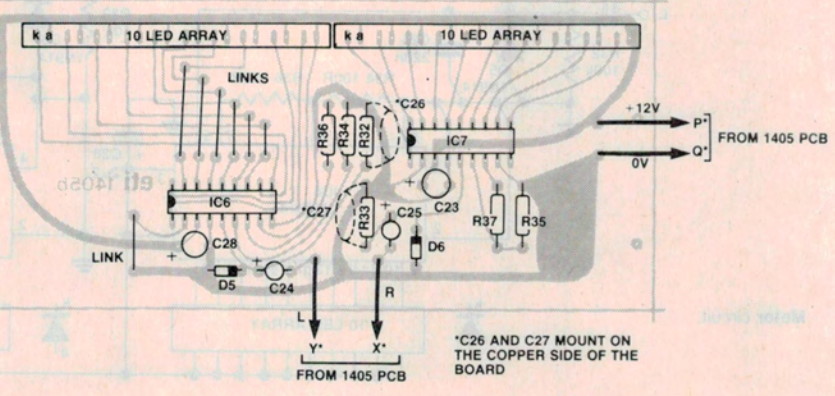
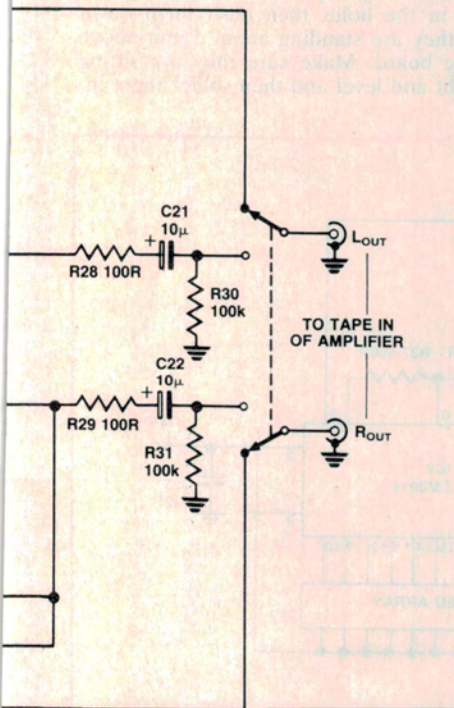
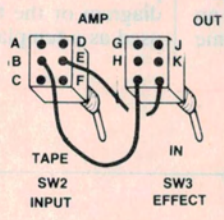
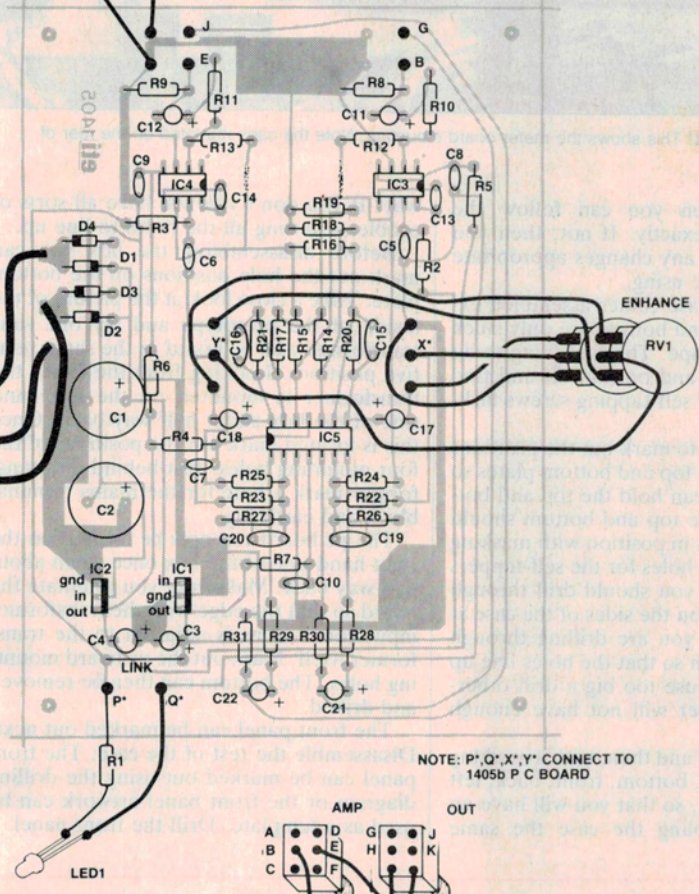

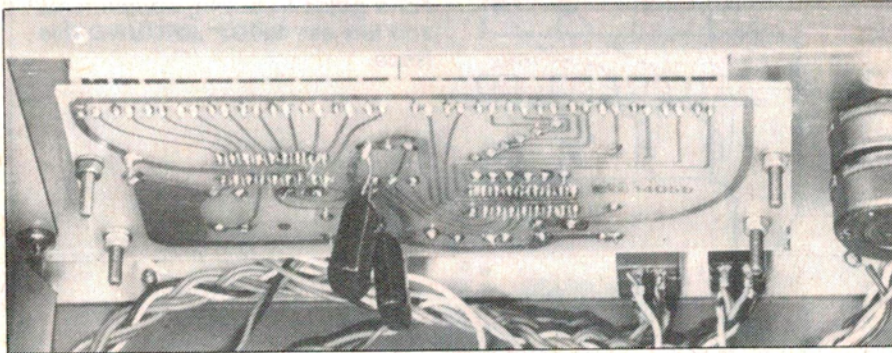

The back of the front! This shows the meter board mounting. Note the caps mounted on the rear of the board.

identical case then you can follow the mounting details exactly. If not, then you will have to make any changes appropriate to the case you are using.

The Horwood case comes assembled except that the top and bottom are only stuck on with masking tape. The first thing to do is to take the top and bottom off and find the little packet of self-tapping screws lurking inside.

The next step is to mark out the positions of the holes on the top and bottom plates so that these screws can hold the top and bottom plates on. The top and bottom should then be stuck back in position with masking tape and the small holes for the self-tappers drilled. Note that you should drill through the mounting lips on the sides of the case at the same time as you are drilling through the top and bottom so that the holes line up accurately. Don't use too big a drill otherwise the self-tapper will not have enough metal to grip.

Take the top off and then, with a marking pen, mark the top, bottom, front, back, left side, right side etc, so that you will have no trouble re-assembling the case the same

way. If you don't you will have all sorts of problems getting all the holes to line up.

Before disassembling the box you can mark out the hole positions on the bottom plate. Take a close look at the picture of the inside of the prototype and lay out your transformer and pc board in the same relative positions. Looking from the front, the transformer is mounted on the left hand side of the box about half way back. Once this is located mark out the positions of the four mounting holes. Just behind the transformer mark a hole for the mains terminal block and earth lug.

The pc board can now be located on the right hand side of the box once again about half way back. Make sure you orientate the board so that the edge with the transformer input connections is adjacent to the transformer itself. Mark out the pc board mounting holes. The bottom can then be removed and drilled.

The front panel can be marked out next. Disassemble the rest of the case. The front panel can be marked out using the drilling diagram or the front panel artwork can be used as a template. Drill the front panel.

The slot for the LED arrays can be made using the old drill, nibble and file method (or fill, dribble and nile if you prefer!). Firstly, drill a series of holes along the centre line of the slot. The drill used should be slightly smaller than the width of the slot. Keep the holes as close together as you can so there is a minimal amount of metal left. A small nibbling tool (hacksaw blade, chisel, sidecutters or whatever!) can then be used to cut out the remaining metal between holes. The slot can then be carefully filed out to size with a small flat file.

Once the front panel is finished you can mark and drill the rear panel. The mains cord and fuse holder sit directly behind the transformer and the RCA sockets mount behind the pc board. To mount the rear panel RCA sockets you will have to position and drill the holes for the lugs and then file out the holes so that there is no metal to metal contact between the RCA sockets and the chassis.

On the prototype I actually cut out a slot so that the lugs would have good clearance. Once the back panel is finished you can put away your drill press and get out your soldering iron for the next step.

Begin the mounting of the components with the display pc board (ETI-1405b). First, check the pc board thoroughly for broken or shorted tracks. Locate and solder in the seven wire links. The resistors and capacitors can be mounted next followed by the diodes. It is advisable to use IC sockets for the LM3914s and these should be mounted next and the ICs put in. Make sure you get them round the right way.

The LED arrays should now be mounted. You may have a little trouble getting them in at first but just persevere. Once you get them in the holes then push them down until they are standing about 5 mm above the pc board. Make sure they are sitting straight and level and then solder them in.

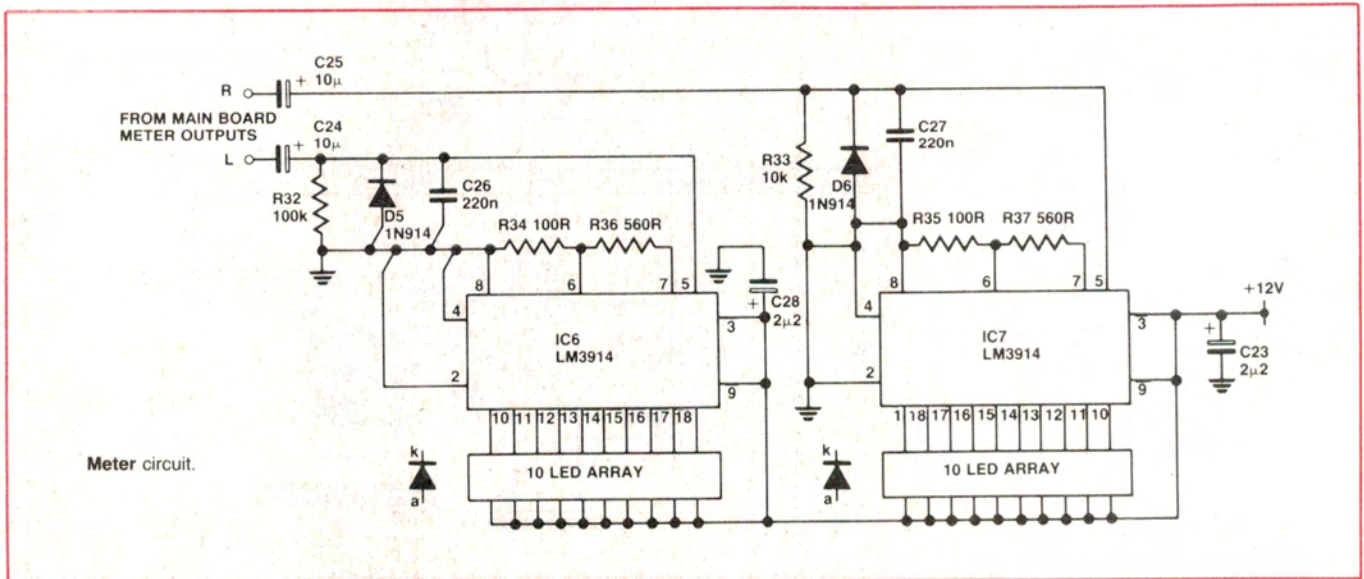

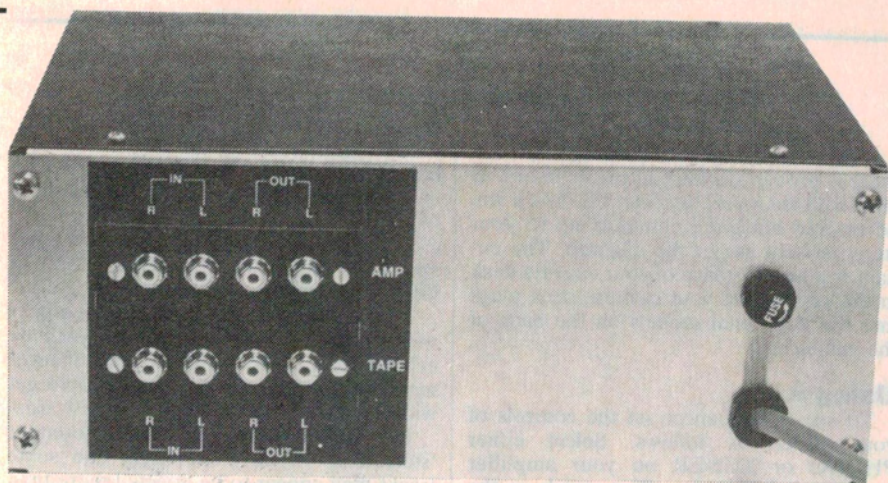

View of the rear panel showing the two RCA arrays.

Take care that you get the displays the right way round as desoldering them can be a real pain in the enhancer.

The two capacitors which mount on the copper side of the board can now be soldered on. The only thing left to be done on this board is to solder about 100 mm lengths of hookup wire to the input and power supply pads.

Turn your attention now to the main pc board. This should be constructed in a similar way to the display board. Resistors and caps first followed by diodes and ICs. Once again take care to get all the polarized components the right way round, especially the big electrolytic caps on the power supply.

Do not use IC sockets with the ICs on this board as the stray resistances and capacitances can degrade the performance of the circuit. Solder pegs should be used on all the flying lead connections on this board to make the wiring up easier.

The next step in construction is to attach the Scotchcal artwork to the front panel. Firstly drill small pilot holes in the centres of all the holes and at the end points of the slot on the Scotchcal. Peel off the backing paper on the Scotchcal and thoroughly wet the back of the Scotchcal and the front panel (the water will allow you to easily peel off the label again if you don't line it up correctly the first time).

Line up the holes on the Scotchcal with the holes drilled in the front panel and then press the Scotchcal firmly in place. Gently rub out the excess water with a soft cloth and set the front panel aside to thoroughly dry. The same treatment can be given to the Scotchcal back panel.

When both the panels are completely dry the holes can be carefully cut out and trimmed using a very sharp knife or scalpel. Try not to tear the Scotchcal or cut off a finger when doing this.

Before re-assembling the case you should attach the mounting bolts for the display board. Sit the display board on the back of the front panel so that the LED displays fit through their slot. Mark out the positions of the mounting holes. Four 20 mm long 6BA flat headed bolts should then be glued to the back of the front panel with Araldite or something similar. Allow the glue to completely harden. The case should now be re-assembled with the exception of the lid.

Now comes the wiring up. Start with the mains wiring. Firstly, securely mount the transformer, terminal block and fuse holder. Mount a length of mains flex using either a clamp type mains grommet or a grommet and separate mains clamp.

Carefully follow the wiring diagram and wire up the mains switch, fuse holder and primary of the transformer with heavy duty hookup wire. Make sure that you insulate any exposed joins or terminals with heat-shrink or insulating tape. **REMEMBER:** mains voltages are lethal so double and triple check your wiring and make sure that you can't accidentally touch any exposed terminals. The mains switch can now be securely mounted to the front panel.

Next mount the display board. The board should be mounted so that the LED arrays protrude about 2 mm through the front panel. The main board can be mounted next using 12 mm spacers.

Using the wiring diagram, wire the secondary of the transformer to the main board. The flying leads from the display board can also be attached to the main board at the appropriate points. The power indicator LED can then be mounted and wired up. The two RCA socket arrays should then be mounted on the rear panel. The input and output wiring, including the

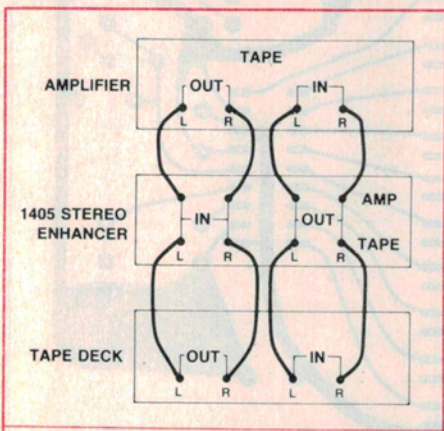

Figure 2. Connecting the stereo enhancer to your amp and tape deck.

Project 1405

two switches, can then be done.

Finally, 250 mm lengths of hookup wire can be attached to the dual 'enhancement' pot and then attached to the pc board. The pot can then be mounted on the front panel and the knob attached.

Testing and setting up

The only real way of testing the enhancer is to turn it on so, with nothing attached to the input or output, plug it into the mains and switch on for a few seconds. The power LED should light and all the display LEDs should remain off. Other than that nothing should happen. If anything else happens (smoke, fire, brimstone, nasty hissing or popping noises, etc) switch off immediately and check everything.

If all is OK then switch on again and try rotating the enhancement pot. The display LEDs should stay off. If any come on then

there is probably a fault in the pc board. If all is well then you turn can off, screw the lid on and hook the enhancer up to your stereo system as per the diagram. The enhancer takes the place of your cassette deck in the system and your cassette deck plugs into the additional sockets on the back of the enhancer.

Using it

To use the enhancer set the controls of your stereo as follows. Select either PHONO or TUNER on your amplifier source switch. Set the effect switch on the enhancer to IN and the input switch to AMP.

Now all you need do is select TAPE on the TAPE/SOURCE button on your amp to cut the effect in. With the TAPE/SOURCE button on SOURCE the effect will be bypassed. To play a cassette through the en-

hancer once again select TAPE on the amp and switch the input switch on the enhancer to TAPE.

To play a cassette without the effect just switch the effect switch on the enhancer to OUT. Don't worry, you'll get the hang of it!

Turning the enhancement control clockwise increases the effect and this will be echoed in the LED display. As the enhancement is increased the bargraph should get wider and wider from the centre outwards.

It should be noted that the amount of 'stereeness' is fairly subjective and some tracks may appear to be affected more than others. At first the effect may sound a little false but it is a bit like 3D pictures in that you must let your brain deceive your senses. When you get over trying to convince yourself that your speakers aren't far enough apart to get good stereo then the effect will be more convincing. ●

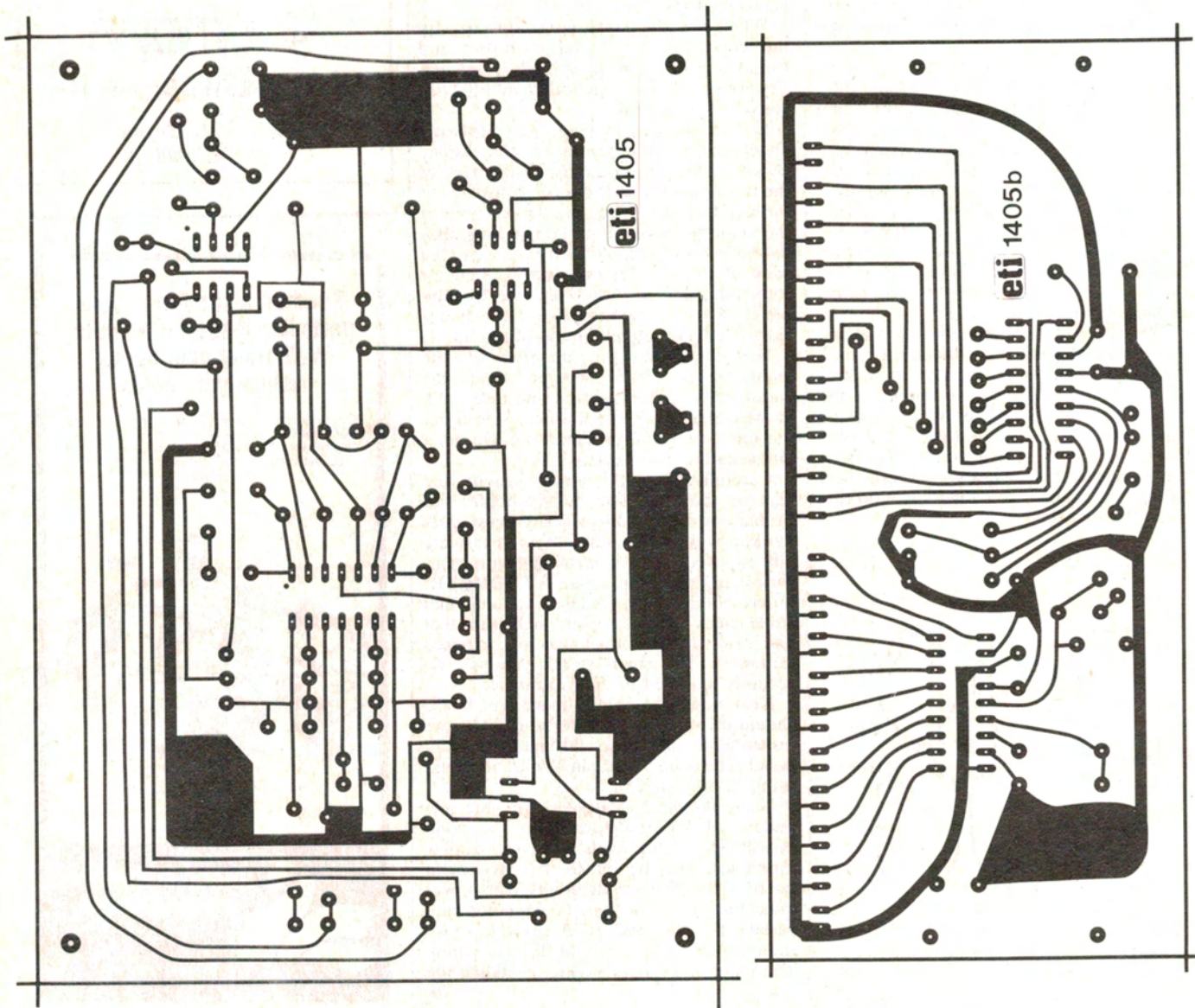

IDEAS FOR EXPERIMENTERS

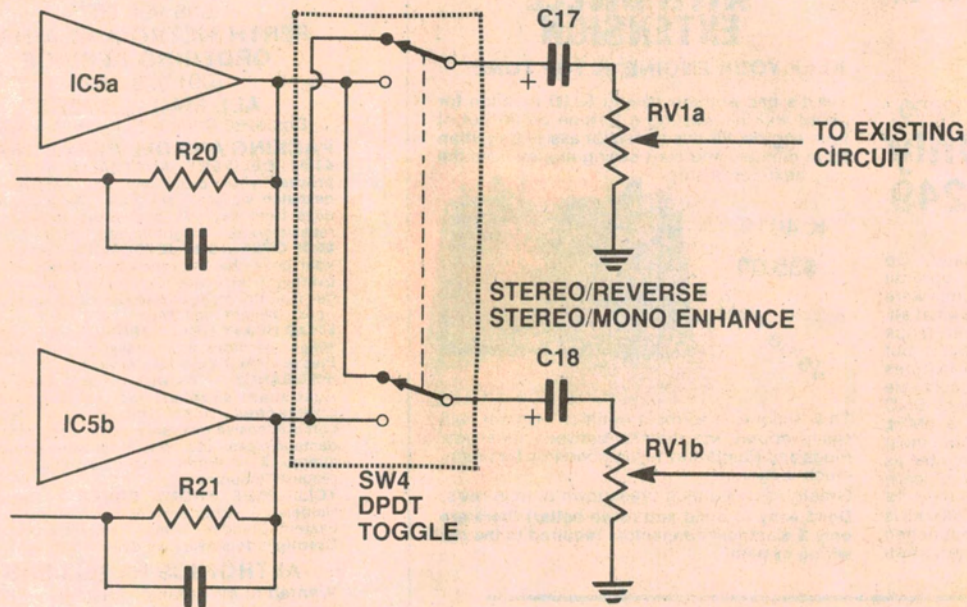

ETI-1405 mod.

T. J. Threiffall writes that the ETI-1405 Stereo Enhancer (March 1985) is an excellent solution to the problem of closely-spaced speakers.

However, there is a simple modification which enables it to be used to solve the opposite problem: that of excessively wide stereo separation when listening to TV/FM 'simulcasts' in a room with loudspeakers at the corners. The width of the sound does not seem to enhance the quality of entertainment — the sound and picture don't come across as being related.

The ETI-1405 with the suggested modification is ideal as a buffer and stereo/reverse, stereo/mono/enhanced unit.

Referring to the original circuit, with the top of RV1a connected to output of IC5a, and RV1b connected to IC5b, outputs are as follows: pot at 0 gives L and R, pot at 50% gives $3L/2 - R/2$ and $3R/2 - L/2$, while the pot at 100% gives $2L - R$ and $2R - L$ — enhanced.

By using a DPDT switch as shown, i.e. swapping the connections of the IC outputs to the pot, the following outputs will be obtained: pot at 0 gives L and R, pot at 50% gives $(L+R)/2$ and $(R+L)/2$, i.e. mono, and pot at 100%, R and L, i.e. reverse stereo. Positions in between those shown will give a continuous range of narrowing of the stereo effect (but remember to use a linear pot for RV1).

Sound Effects Generator

This circuit was sent to us by **Tom Mollenmane**, aged 14. It is a simple sound generator, the frequency depending on the values in the RC network consisting of R1, C1 and VR1. The variable resistor VR2 is inserted to let you make allowance for changes in the battery voltage as it decays.

