

## Improving VCA Performance II & III

*The circuits within this application note feature THAT218x to provide the essential function of voltage-controlled amplifier (VCA) and THAT 2252 as an rms-level detector (RMS). Since writing this note, THAT has introduced a new dual VCA, as well as several Analog Engines®. Analog Engines combine a VCA and an RMS with optional opamps in one part. With minor modifications, these newer ICs are generally applicable to the designs shown herein, and may offer advantages in performance, cost, power consumption, etc., depending on the design requirements. We encourage readers to consider the following alternatives in addition to the 218x and 2252:*

- *Analog Engine (VCA, RMS, opamps): 4301*
- *Analog Engine with low supply voltage and power consumption (VCA, RMS, opamps): 4320*
- *Analog Engine with low cost, supply voltage, and power consumption (VCA, RMS): 4315*
- *Analog Engine with low cost and power consumption (VCA, RMS): 4305*
- *Dual (VCA only): 2162*

*For more information about making these substitutions, please contact THAT Corporation's technical support group at [apps\\_support@thatcorp.com](mailto:apps_support@thatcorp.com).*

**THAT** Corporation

45 Sumner St, Milford, MA 01757-1656 USA; [www.thatcorp.com](http://www.thatcorp.com); [info@thatcorp.com](mailto:info@thatcorp.com)

## Improving VCA Performance II

### Noise modulation via the VCA control port

An important element in designing a superior circuit with a VCA is to understand the problem of noise modulation, the condition whereby a signal passing through the VCA is multiplied by noise on the control port. Because VCAs are essentially multipliers, noise modulation may not be noticeable when measuring the noise floor with no input signal. In this case one of the operands (the signal input) becomes zero, and the output due to noise modulation is rendered unmeasurable, or nearly so. In order to ascertain the effects of noise modulation, then, measurements must be taken in the presence of an input signal.

In many applications, the control port of a VCA is driven by an op amp, and the noise performance of the op amp can have a significant effect on the noise modulation, and hence the overall sound, of the VCA. In a section of his paper entitled "An Improved Monolithic Voltage-Controlled Amplifier", Gary Hebert compares the residual noise of a VCA driven by an AD797 and then by a TLO81. At unity gain, the circuit using an AD797 has noise that is approximately 20dB better than the circuit using the TLO81.

In our experience, the TLO81, LF353, and similar op-amps are usually too noisy for use in a VCA's side-chain, while the AD797 may be overkill in many applications. Good choices include the LM833, the OP-275, or the NE5532, with noise levels 3-4 times lower than the LF353.

## Improving VCA Performance III

### Preventing inductive control-port oscillation

Almost any "audio" op amp will successfully drive the control port of a single VCA over a short trace on a printed circuit board. However, op amps have closed-loop output impedances that act inductive above some frequency because their impedance goes up with frequency. Op amps with limited gain-bandwidth product (like the LF353) exhibit inductive output impedance at relatively low frequencies, and this can occasionally result in VCA oscillation, especially if these op amps are used to drive the control ports a) of multiple VCAs, or b) over long cable lengths.

Though this type of oscillation is not common, we recommend using the NE5532, OP-275, LM833, or other op amps with at least 8 or 9 MHz of gain-bandwidth product. An alternative is shown in the following schematic of a typical compressor. R3 and C1, which are series connected to the control port, are the operative components in maintaining stability. The 51 $\Omega$  resistor keeps the control port buffer stable, and the 2.2nF capacitor adds some -j that cancels the +j resulting from the amplifiers inductive output. This additional circuitry will help desensitize the VCA to control-port inductance, though some experimentation with values may be required to settle on proper values that match a given op amp model.

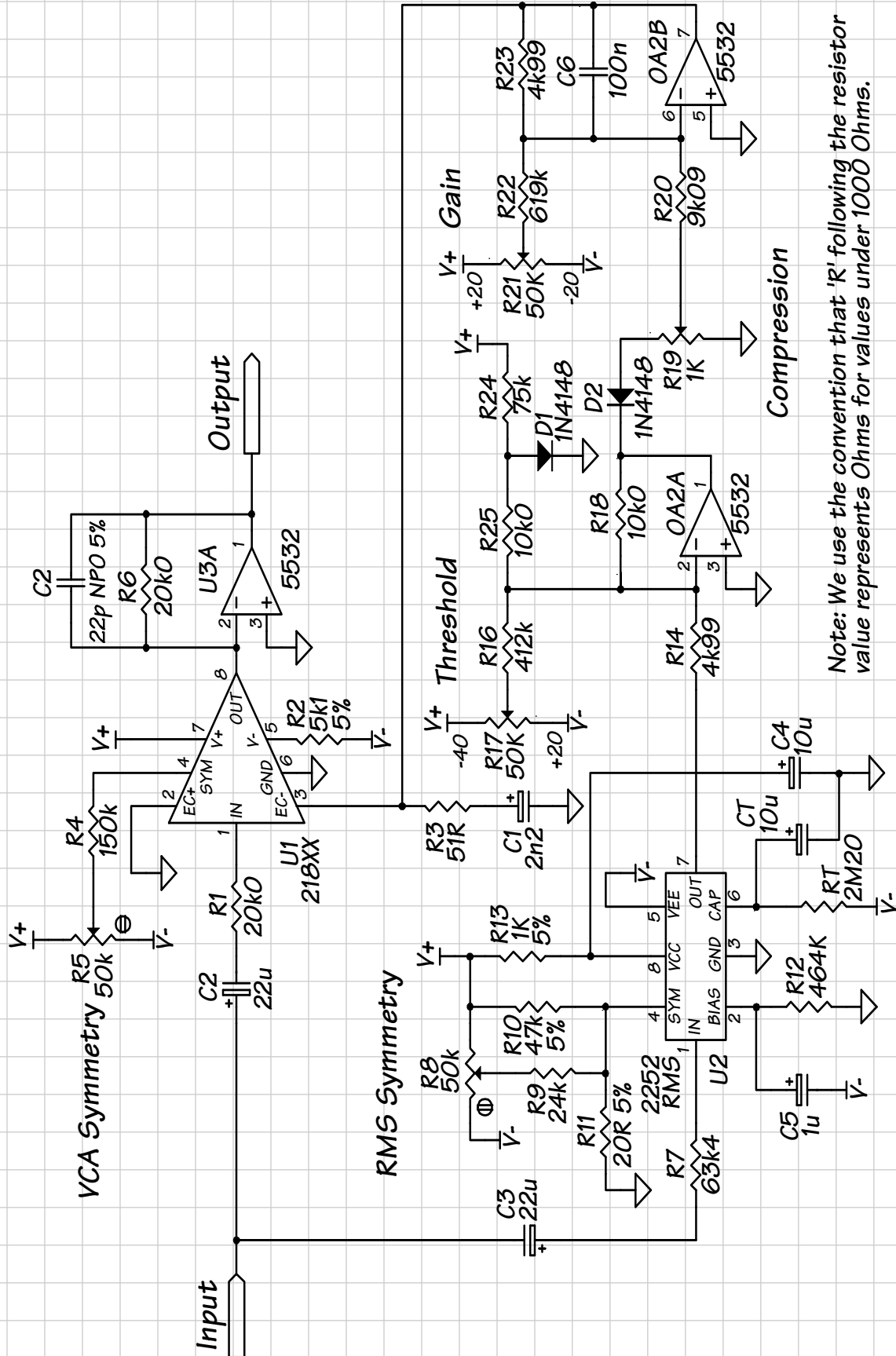

Note: We use the convention that 'R' following the resistor value represents Ohms for values under 1000 Ohms.

Typical compressor with improved VCA performance