

Adjustable Ducker using the THAT4301

Duckers are usually used to reduce the level of the main program material during announcements. In this circuit, while the "voice over" signal is below threshold, the main program passes through the VCA at a fixed gain, determined by the position of VR4. The RMS detector, which senses the level of the "voice over" signal, is set for a zero dB reference level of -10dBu. This level has been chosen arbitrarily, and the circuit is configured for operation about -10dBu as follows:

The timing current is determined by the equation: $I_t = \frac{V_-}{R7}$, and the OdB input reference current is related to I_t by the constant $\sqrt{9.6 \times 10^{-6}}$, as follows,

$$I_{in_{OdB}} = 1.13 \times I_t$$

For a reference voltage of -10 dBu, the value of the RMS-Detector's input voltage-to-current resistor becomes

$$R1 = \frac{V_{in_{OdB}}}{I_{in_{OdB}}} = \frac{0.245V}{8.5\mu A} \approx 28.8k\Omega$$

This setting will result in the RMS detector having zero volts out (and the ducker having unity gain) when the "voice over" signal level is below -10 dBu. VR2 provides the means for user adjustment of this level.

The threshold amplifier's output, at the junction of D1, R2 and R6, is zero volts when the "voice over" signal is below the threshold level, but decreases rapidly once the gating signal exceeds threshold. In this design, a gain of 10 is provided to aid in ducking the program material during announcements. Thus, when the "voice over" signal is 3dB over threshold, the program material will be suppressed by 30dB. The designer may wish to experiment with this gain level, by varying R2, in order to get the right "feel" when ducking.

During ducking, the "voice over" signal is injected into the VCA's output amplifier via R3. Note that there is an inversion for this signal that is not present in the program material. This should be of little consequence for announcements, though the designer may want to include an inverter in the "voice over" signal path if using this circuit in other applications such as "punching in" audio during recording, in order to maintain phase integrity.

In this design, we have chosen a relatively slow time constant, but this can easily be altered by C4. See the THAT 4301's data sheet for details.

Adjustable Ducker using the THAT4301

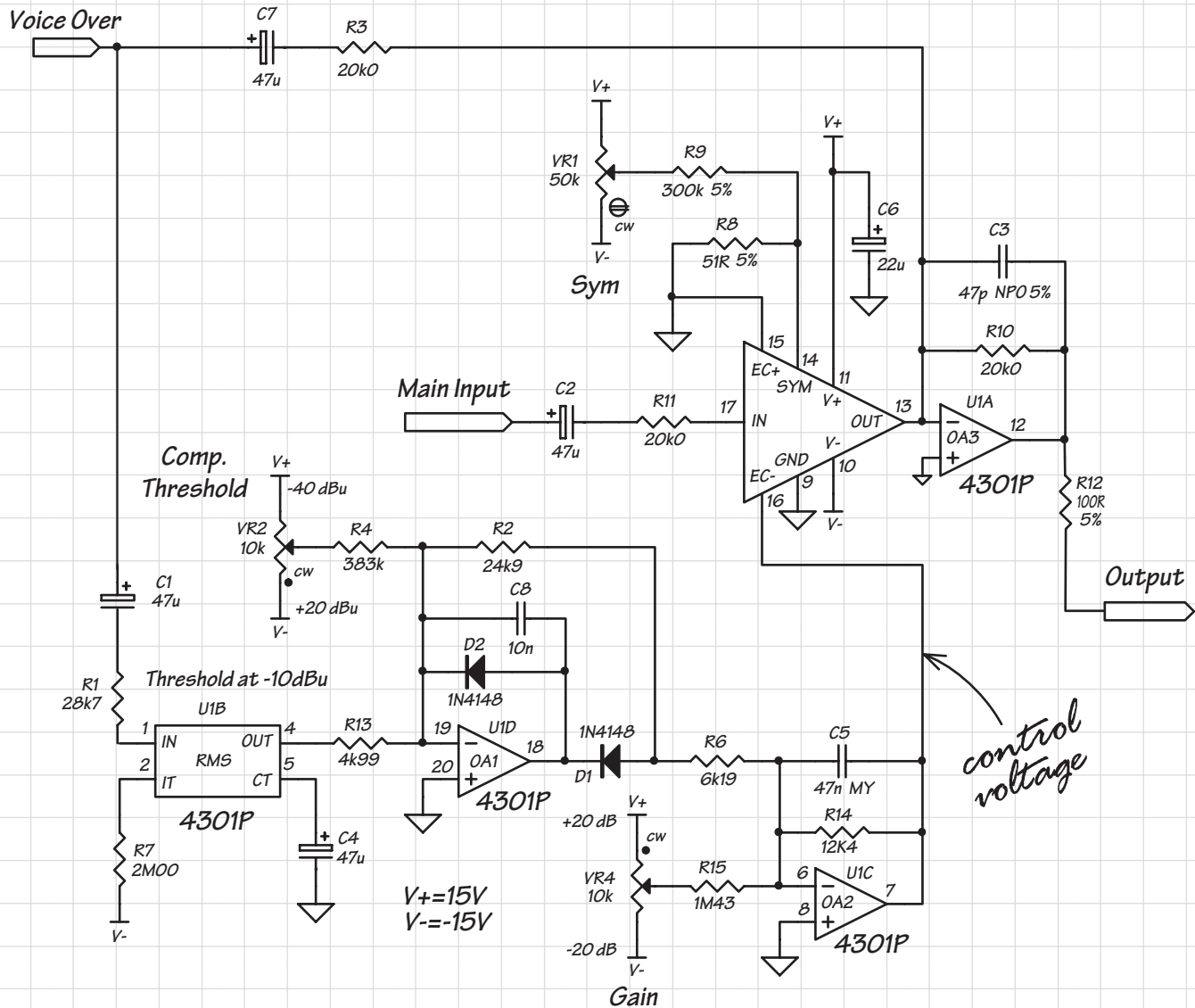

Figure 1: Adjustable ducker