

Precision AC/DC Converters

National Semiconductor
Linear Brief 8



LB-8

Although semiconductor diodes available today are close to "ideal" devices, they have severe limitations in low level applications. Silicon diodes have a 0.6V threshold which must be overcome before appreciable conduction occurs. By placing the diode in the feedback loop of an operational amplifier, the threshold voltage is divided by the open loop gain of the amplifier. With the threshold virtually eliminated, it is possible to rectify millivolt signals.

Figure 1 shows the simplest configuration for eliminating diode threshold potential. If the voltage at the non-inverting input of the amplifier is positive, the output of the LM101A

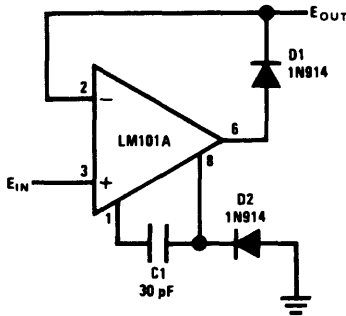

TL/H/8459-1

FIGURE 1. Precision Diode

swings positive. When the amplifier output swings 0.6V positive, D₁ becomes forward biased; and negative feedback through D₁ forces the inverting input to follow the non-inverting input. Therefore, the circuit acts as a voltage follower for positive signals. When the input swings negative, the output swings negative and D₁ is cut off. With D₁ cut off no current flows in the load except the 30 nA bias current of the LM101A. The conduction threshold is very small since less than 100 μV change at the input will cause the output of the LM101A to swing from negative to positive.

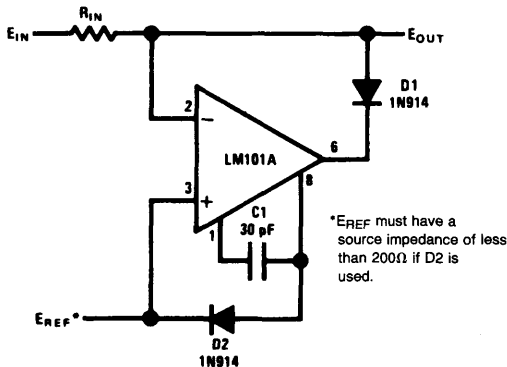

*E_{REF} must have a source impedance of less than 200Ω if D₂ is used.

TL/H/8459-2

FIGURE 2. Precision Clamp

A useful variation of this circuit is a precision clamp, as is shown in Figure 2. In this circuit the output is precisely clamped from going more positive than the reference voltage. When E_{IN} is more positive than E_{REF}, the LM101A functions as a summing amplifier with the feedback loop closed through D₁. Neglecting offsets, negative feedback keeps the summing node, and therefore the output, within 100 μV of the voltage at the non-inverting input. When E_{IN} is about 100 μV more negative than E_{REF}, the output swings positive, reverse biasing D₁. Since D₁ now prevents negative feedback from controlling the voltage at the inverting input, no clamping action is obtained. On both of the circuits in Figures 1 and 2 an output clamp diode is added at pin 8 to help speed response. The clamp prevents the operational amplifier from saturating when D₁ is reverse biased. When D₁ is reverse biased in either circuit, a large differential voltage may appear between the inputs of the LM101A. This is necessary for proper operation and does no damage since the LM101A is designed to withstand large input voltages. These circuits will not work with amplifiers protected with back to back diodes across the inputs. Diode protection conducts when the differential input voltage exceeds 0.6V and would connect the input and output together. Also, unprotected devices such as the LM709, are damaged by large differential input signals.

The circuits in Figures 1 and 2 are relatively slow. Since there is 100% feedback for positive input signals, it is necessary to use unity gain frequency compensation. Also, when D₁ is reverse biased, the feedback loop around the amplifier is opened and the input stage saturates. Both of these conditions cause errors to appear when the input frequency exceeds 1.5 kHz. A high performance precision half wave rectifier is shown in Figure 3. This circuit will provide rectification with 1% accuracy at frequencies from dc to 100 kHz. Further, it is easy to extend the operation to full wave rectification for precision AC/DC converters.

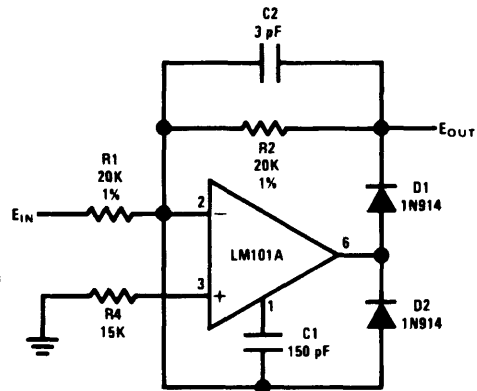

TL/H/8459-3

FIGURE 3. Fast Half Wave Rectifier

This precision rectifier functions somewhat differently from the circuit in *Figure 1*. The input signal is applied through R_1 to the summing node of an inverting operational amplifier. When the signal is negative, D_1 is forward biased and develops an output signal across R_2 . As with any inverting amplifier, the gain is R_2/R_1 . When the signal goes positive, D_1 is non-conducting and there is no output. However, a negative feedback path is provided by D_2 . The path through D_2 reduces the negative output swing to $-0.7V$, and prevents the amplifier from saturating.

Since* the LM101A is used as an inverting amplifier, feedforward compensation can be used. Feedforward compensation increases the slew rate to $10 V/\mu s$ and reduces the gain error at high frequencies. This compensation allows the half wave rectifier to operate at higher frequencies than the previous circuits with no loss in accuracy.

The addition of a second amplifier converts the half wave rectifier to a full wave rectifier. As is shown in *Figure 4*, the half wave rectifier is connected to inverting amplifier A_2 . A_2 sums the half wave rectified signal and the input signal to provide a full wave output. For negative input signals the output of A_1 is zero and no current flows through R_3 . Neglecting for the moment C_2 , the output of A_2 is $-\frac{R_7}{R_6} E_{IN}$. For positive input signals, A_2 sums the currents through R_3 and R_6 ; and

$$E_{OUT} = R_7 \left[\frac{E_{IN}}{R_3} - \frac{E_{IN}}{R_6} \right].$$

If R_3 is $\frac{1}{2} R_6$, the output is $\frac{R_7}{R_6} E_{IN}$. Hence, the output is always the absolute value of the input.

Filtering, or averaging, to obtain a pure dc output is very easy to do. A capacitor, C_2 , placed across R_7 rolls off the frequency response of A_2 to give an output equal to the average value of the input. The filter time constant is $R_7 C_2$, and must be much greater than the maximum period of the input signal. For the values given in *Figure 4*, the time constant is about 2.0 seconds. This converter has better than 1% conversion accuracy to above 100 kHz and less than 1% ripple at 20 Hz. The output is calibrated to read the rms value of a sine wave input.

As with any high frequency circuit some care must be taken during construction. Leads should be kept short to avoid stray capacitance and power supplies bypassed with $0.01 \mu F$ disc ceramic capacitors. Capacitive loading of the fast rectifier circuits must be less than 100 pF or decoupling becomes necessary. The diodes should be reasonably fast and film type resistors used. Also, the amplifiers must have low bias currents.

REFERENCES

*R. C. Dobkin, "Feedforward Compensation Speeds Op Amp," *National Semiconductor Corporation, LB-2*, March, 1969.

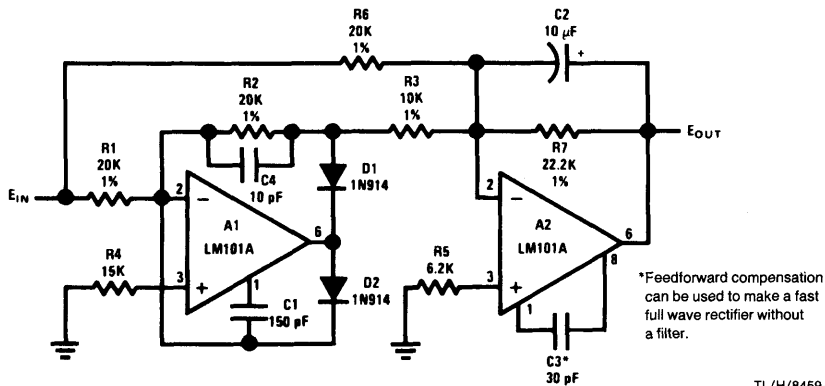

TL/H/8459-4

FIGURE 4. Precision AC to DC Converter